

Kawasaki

**Z250
KZ305**

Jim Schmidt



**Motorcycle
Service Manual**

Decimal Equivalents

| INCH | | | | MM INCH | INCH | | | | MM INCH |
|-----------------|-----------------|----------------|--|---------------------|-----------------|-----------------|-----------------|--|----------------------|
| $\frac{1}{64}$ | | | | 1mm= .03937 inch | $\frac{33}{64}$ | | | | 14mm= .55118 inch |
| | $\frac{1}{32}$ | | | | $\frac{17}{32}$ | | | | |
| $\frac{3}{64}$ | | | | | $\frac{35}{64}$ | | | | |
| | | $\frac{1}{16}$ | | | | | $\frac{9}{16}$ | | |
| $\frac{5}{64}$ | | | | | $\frac{37}{64}$ | | | | |
| | $\frac{3}{32}$ | | | | | $\frac{19}{32}$ | | | |
| $\frac{7}{64}$ | | | | | $\frac{39}{64}$ | | | | |
| | | $\frac{1}{8}$ | | | | | $\frac{5}{8}$ | | |
| $\frac{9}{64}$ | | | | | $\frac{41}{64}$ | | | | |
| | $\frac{5}{32}$ | | | | | $\frac{21}{32}$ | | | |
| $\frac{11}{64}$ | | | | | $\frac{43}{64}$ | | | | |
| | | $\frac{3}{16}$ | | | | | $\frac{11}{16}$ | | |
| $\frac{13}{64}$ | | | | | $\frac{45}{64}$ | | | | |
| | $\frac{7}{32}$ | | | | | $\frac{23}{32}$ | | | |
| $\frac{15}{64}$ | | | | | $\frac{47}{64}$ | | | | |
| | | $\frac{1}{4}$ | | | | | $\frac{3}{4}$ | | |
| $\frac{17}{64}$ | | | | $\frac{49}{64}$ | | | | | |
| | $\frac{9}{32}$ | | | | $\frac{25}{32}$ | | | | |
| $\frac{19}{64}$ | | | | $\frac{51}{64}$ | | | | | |
| | | $\frac{5}{16}$ | | | | $\frac{13}{16}$ | | | |
| $\frac{21}{64}$ | | | | $\frac{53}{64}$ | | | | | |
| | $\frac{11}{32}$ | | | | $\frac{27}{32}$ | | | | |
| $\frac{23}{64}$ | | | | $\frac{55}{64}$ | | | | | |
| | | $\frac{3}{8}$ | | | | $\frac{7}{8}$ | | | |
| $\frac{25}{64}$ | | | | $\frac{57}{64}$ | | | | | |
| | $\frac{13}{32}$ | | | | $\frac{29}{32}$ | | | | |
| $\frac{27}{64}$ | | | | $\frac{59}{64}$ | | | | | |
| | | $\frac{7}{16}$ | | | | $\frac{15}{16}$ | | | |
| $\frac{29}{64}$ | | | | $\frac{61}{64}$ | | | | | |
| | $\frac{15}{32}$ | | | | $\frac{31}{32}$ | | | | |
| $\frac{31}{64}$ | | | | $\frac{63}{64}$ | | | | | |
| | | $\frac{1}{2}$ | | | | | | | |
| | | | | | | 1 | 1. | | |

Unit Conversion Table

| | | | | |
|---------------------|---|--------|---|---------------------|
| cc | x | .0610 | = | cu in |
| cc | x | .02816 | = | oz (imp) |
| cc | x | .03381 | = | oz (US) |
| cu in | x | 16.39 | = | cc |
| ft-lbs | x | 12 | = | in lbs |
| ft-lbs | x | .1383 | = | kg-m |
| gal (imp) | x | 4.546 | = | litres |
| gal (imp) | x | 1.201 | = | gal (US) |
| gal (US) | x | 3.7853 | = | liters |
| gal (US) | x | .8326 | = | gal (Imp) |
| grams | x | .03527 | = | oz |
| in | x | 25.40 | = | mm |
| in lbs | x | .0833 | = | ft-lbs |
| in lbs | x | .0115 | = | kg-m |
| kg | x | 2.2046 | = | lbs |
| kg | x | 35.274 | = | oz |
| kg-m | x | 7.233 | = | ft-lbs |
| kg-m | x | 86.796 | = | in-lbs |
| kg/cm ² | x | 14.22 | = | lbs/in ² |
| km | x | .6214 | = | mile |
| lb | x | .4536 | = | kg |
| lb/in ² | x | .0703 | = | kg/cm ² |
| litre | x | 28.16 | = | oz (imp) |
| litre | x | 33.81 | = | oz (US) |
| litre | x | .8799 | = | qt (imp) |
| litre | x | 1.0567 | = | qt (US) |
| metre | x | 3.281 | = | ft |
| mile | x | 1.6093 | = | km |
| mm | x | .03937 | = | in |
| oz (imp) | x | 35.51 | = | cc |
| oz (US) | x | 29.57 | = | cc |
| oz (weight) | x | 28.35 | = | grams |
| qt (imp) | x | 1.1365 | = | litre |
| qt (imp) | x | 1.201 | = | qt (US) |
| qt (US) | x | .9463 | = | litre |
| qt (US) | x | .8326 | = | qt (imp) |
| kg/cm ² | x | 98.07 | = | kPa |
| lbs/in ² | x | 6.896 | = | kPa |
| kPa | x | .1450 | = | lbs/in ² |

$$^{\circ}\text{C} \rightarrow ^{\circ}\text{F}: \frac{9(^{\circ}\text{C} + 40)}{5} - 40 = ^{\circ}\text{F}$$

$$^{\circ}\text{F} \rightarrow ^{\circ}\text{C}: \frac{5(^{\circ}\text{F} + 40)}{9} - 40 = ^{\circ}\text{C}$$

List of Abbreviations

| | |
|---------------------|---------------------------------|
| ABDC | after bottom dead center |
| ATDC | after top dead center |
| BBDC | before bottom dead center |
| BDC | bottom dead center |
| BTDC | before top dead center |
| cc | cubic centimeters |
| cu in | cubic inches |
| ft | foot, feet |
| ft-lbs | foot-pounds |
| gal | gallon, gallons |
| hp | horsepower |
| in | inch, inches |
| in-lb | inch-pounds |
| kg | kilogram, kilograms |
| kg/cm ² | kilograms per square centimeter |
| kg-m | kilogram meters |
| km | kilometer |
| kph | kilometers per hour |
| lb, lbs | pound, pounds |
| lbs/in ² | pounds per square inch |
| ltr | liter, litre |
| m | meter, meters |
| mi | mile, miles |
| mm | millimeters |
| mph | miles per hour |
| oz | ounce, ounces |
| psi | pounds per square inch |
| qt | quart, quarts |
| rpm | revolutions per minute |
| sec | second, seconds |
| SS | standing start |
| TDC | top dead center |
| " | inch, inches |
| r/min | revolutions per minute |
| ℓ | liter, litre |
| kPa | kilo-Pascals |

K
Kawasaki

Z250
KZ305

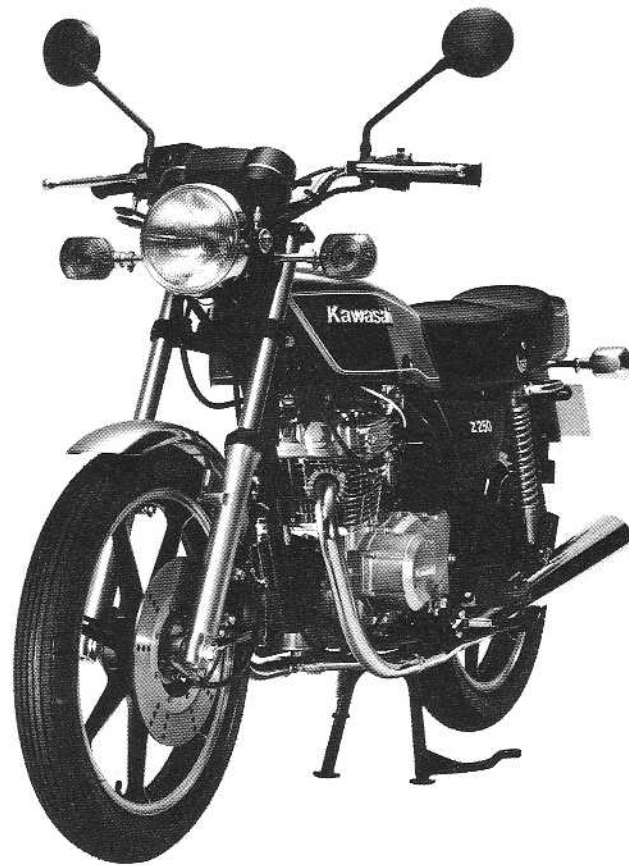

Motorcycle

Service Manual

Kawasaki Heavy Industries, Ltd. accepts no liability for any inaccuracies or omissions in this publication, although every possible care has been taken to make it as complete and accurate as possible. All procedures and specifications subject to change without prior notice, and may not apply to every country.

EMISSION CONTROL INFORMATION

To protect the environment in which we all live, Kawasaki has incorporated two emission control systems in compliance with the applicable regulations of the United States Environmental Protection Agency.

1. Crankcase Emission Control System

This system eliminates the release of crankcase vapors into the atmosphere. Instead, the vapors are routed through an oil separator to the intake side of the engine. While the engine is operating, the vapors are drawn into the combustion chamber, where they are burned along with the fuel and air supplied by the carburetors.

2. Exhaust Emission Control System

This system reduces the amount of pollutants discharged into the atmosphere by the exhaust of this motorcycle. The fuel and ignition systems of this motorcycle have been carefully designed and constructed to ensure an efficient engine with low exhaust pollutant levels.

The Clean Air Act, which is the Federal law covering motor vehicle pollution, contains what is commonly referred to as the Act's "tampering provisions".

"Sec. 203(a) The following acts and the causing thereof are prohibited...

(3)(A) for any person to remove or render inoperative any device or element of design installed on or in a motor vehicle or motor vehicle engine in compliance with regulations under this title prior to its sale and delivery to the ultimate purchaser, or for any manufacturer or dealer knowingly to remove or render inoperative any such device or element of design after such sale and delivery to the ultimate purchaser.

(3)(B) for any person engaged in the business of repairing, servicing, selling, leasing, or trading motor vehicles or motor vehicle engines, or who operates a fleet of motor vehicles knowingly to remove or render inoperative any device or element of design installed on or in a motor vehicle or motor vehicle engine in compliance with regulations under this title following its sale and delivery to the ultimate purchaser..."

Note: The phrase "remove or render inoperative any device or element of design" has been generally interpreted as follows:

1. Tampering does not include the temporary removal or rendering inoperative of devices or elements of design in order to perform maintenance.

EMISSION CONTROL INFORMATION (CONT.)

2. Tampering could include:

- a. Maladjustment of vehicle components such that the emission standards are exceeded.
- b. Use of replacement parts or accessories which adversely affect the performance or durability of the motorcycle.
- c. Addition of components or accessories that result in the vehicle exceeding the standards.
- d. Permanently removing, disconnecting, or rendering inoperative any component or element of design of the emission control systems.

WE RECOMMEND THAT ALL DEALERS OBSERVE THESE PROVISIONS OF FEDERAL LAW, THE VIOLATION OF WHICH IS PUNISHABLE BY CIVIL PENALTIES NOT EXCEEDING \$10,000 PER VIOLATION.

Foreword

This manual is designed primarily for use by motorcycle mechanics in a properly equipped shop, although it contains enough detail and basic information to make it useful to the motorcycle user who desires to carry out his own basic maintenance and repair work. Since a certain basic knowledge of mechanics, the proper use of tools, and workshop procedures must be understood in order to carry out maintenance and repair satisfactorily; the adjustments, maintenance, and repair should be carried out only by qualified mechanics whenever the owner has insufficient experience, or has doubts as to his ability to do the work, so that the motorcycle can be operated safely.

In order to perform the work efficiently and to avoid costly mistakes, the mechanic should read the text, thoroughly familiarizing himself with the procedures before starting work, and then do the work carefully in a clean area. Whenever special tools or equipment is specified, makeshift tools or equipment should not be used. Precision measurements can only be made if the proper instruments are used, and the use of substitute tools may adversely affect safe operation of the motorcycle.

Whenever you see the symbols shown below, heed their instructions! Always follow safe operating and maintenance practices.

WARNING

This warning symbol identifies special instructions or procedures which, if not correctly followed, could result in personal injury, or loss of life.

CAUTION

This caution symbol identifies special instructions or procedures which, if not strictly observed, could result in damage to, or destruction of equipment.

"NOTE" indicates points of particular interest for more efficient and convenient operation.

This manual is divided into the following chapters:

(1) Adjustment

The adjustment chapter gives the procedure for all adjustments which may become necessary periodically and which do not involve major disassembly.

(2) Disassembly

This chapter shows the best method for the removal, disassembly, assembly, and installation which are necessary for maintenance and repair. Do not disassemble the component parts further than explained here. Since assembly and installation are usually the reverse of disassembly and removal, assembly and installation are not explained in detail in some cases. Instead, assembly notes and installation notes are provided to explain special points.

In cases the removal procedures are apparent without explanation such as for the seat or side stand, no information is given.

(3) Maintenance

The procedures for inspection and repair are described in detail in this chapter.

(4) Appendix

The appendix in the back of this manual contains miscellaneous information, including a special tool list and a wiring diagram.

(5) Supplement

The maintenance and repair procedures, that are unique to later year units since the first publication of the Service Manual, are explained in this chapter per one year unit.

Since the Service Manual is based on the first production units of the 1979 Z250-A1, there may be minor discrepancies between some vehicles and the illustrations and text in this manual. Explanations on major changes and additions pertaining to later year units will be added in the end of the supplement by a new edition, as required.

QUICK REFERENCE GUIDE

To use, bend the manual back and match the desired section below against the black spot showing at the edge of these pages. 

| | |
|------------------------|-----------------------------|
| Specifications | A |
| Adjustment | Engine B |
| | Chassis C |
| Disassembly | Introduction D |
| | Engine (Installed) E |
| | Engine (Removed) F |
| | Chassis G |
| Maintenance | Engine H |
| | Chassis J |
| | Electrical K |
| Troubleshooting | L |
| Appendix | M |
| Supplement | N |
| Index | P |

4 MODEL IDENTIFICATION

Model Identification

Z250-A1 Left Side View

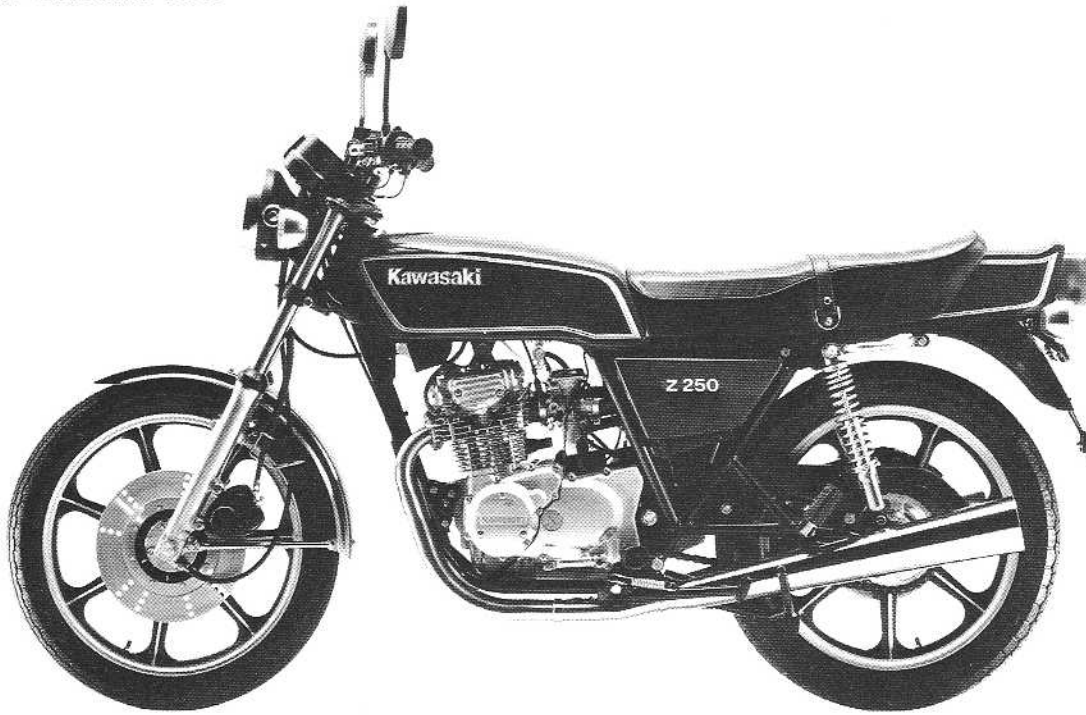

Z250-A1 Right Side View



Specifications

A

Table of Contents

| | |
|---------------------------------|----|
| SPECIFICATIONS | 6 |
| ENGINE PERFORMANCE CURVES | 8 |
| RUNNING PERFORMANCE CURVES..... | 9 |
| PERIODIC MAINTENANCE CHART..... | 10 |

6 SPECIFICATIONS

SPECIFICATIONS

Z250-A1, A2

Dimensions

| | |
|--------------------|---|
| Overall length | 2,020 mm, (UK) 2,015 mm, (E) (A) 2,060 mm |
| Overall width | 760 mm, (E) 740 mm |
| Overall height | 1,085 mm, (E) 1,070 mm |
| Wheelbase | 1,340 mm |
| Road clearance | 145 mm, (E) 140 mm |
| Dry weight | 153 kg |
| Fuel tank capacity | 13.6 ℓ |

Performance

| | |
|------------------------|--------------------|
| Climbing ability | 25° |
| Braking Distance | 12.5 m from 50 kph |
| Minimum turning radius | 2.2 m |

Engine

| | | |
|---------------------|---|----------|
| Type | SOHC 2 cylinder, 4 stroke, air cooled | |
| Bore and stroke | 55.0 x 52.4 mm | |
| Displacement | 248 cc | |
| Compression ratio | 9.5 | |
| Maximum horsepower | 27 HP @10,000 rpm | |
| Maximum torque | 2.1 kg-m (15 ft-lbs) @8,500 rpm | |
| Valve timing | | |
| Inlet | Open | 21° BTDC |
| | Close | 59° ABDC |
| | Duration | 260° |
| Exhaust | Open | 61° BBDC |
| | Close | 19° ATDC |
| | Duration | 260° |
| Carburetors | Keihin CV32 x 2 | |
| Lubrication system | Forced lubrication (wet sump) | |
| Engine oil | SE class SAE 10W40, 10W50, 20W40 or 20W50 | |
| Engine oil capacity | 1.8 ℓ | |
| | 1.5 ℓ (without filter change) | |
| Starting system | Electric starter | |
| Ignition system | Battery and coil | |
| Ignition timing | From 10° BTDC @1,250 rpm to 40° BTDC @3,000 rpm | |
| Spark plugs | NGK D8EA or ND X24ES-U | |
| | (E) NGK DR8ES or ND X24ESR-U | |

Transmission

| | |
|-----------------|--------------------------------------|
| Type | 6-speed, constant mesh, return shift |
| Clutch | Wet, multi disc |
| Gear ratio: 1st | 2.60 (39/15) |
| 2nd | 1.79 (34/19) |
| 3rd | 1.41 (31/22) |
| 4th | 1.16 (29/25) |
| 5th | 1.00 (27/27) |
| 6th | 0.89 (25/28) |

| | |
|-------------------------|------------------|
| Primary reduction ratio | 3.74 (71/19) |
| Final reduction ratio | 2.33 (35/15) |
| Overall drive ratio | 7.79 (@Top gear) |

Electrical Equipment

| | |
|-------------------------|--|
| Alternator Rated Output | 13.5 amp. @8,000 rpm, 14V |
| Regulator/Rectifier | Shindengen SH221-12 |
| Ignition coil | Toyo denso ZC003-12V |
| Battery | Yuasa YB10L-A2 (12V 10AH) |
| Starter | Mitsuba SM-725-I |
| Headlight type | Semi-sealed |
| Headlight | 12V 50/40W, (E) 12V 35/35W, (F) 12V 36/36W |
| Tail/Brake light | 12V 8/27W, (E) (A) 12V 5/21W |
| City light | 12V 3W, (E) 12V 4W |
| Turn signal lights | 12V 23W, (E) 12V 21W |
| Meter lights | 12V 3.4W |
| Indicator lights | 12V 3.4W |
| Horn | 12V 2A |

Frame

| | | |
|-------------------------------------|-------|------------------------|
| Type | | Tubular, single cradle |
| Steering angle | | 40° to either side |
| Castor | | 27° |
| Trail | | 100 mm |
| Tire size | Front | 3.00S-18 4PR |
| | Rear | 3.50S-18 4PR |
| Suspension | Front | Telescopic fork |
| | Rear | Swing arm |
| Wheel travel | Front | 150 mm |
| | Rear | 98 mm |
| Front fork oil capacity (each fork) | | 150 cc |
| Front fork oil type | | SAE 5W20 |

Brakes

| | | |
|-------------------------|----------------|------------|
| Type | Front and Rear | Disc brake |
| Effective disc diameter | Front | 230 mm |
| | Rear | 218 mm |

(E) : European model, (EI) : European model except Italian model, (F) : French model,
 (UK) : U.K. model, (A) : Australian model

Specifications subject to change without notice, and may not apply to every country.

8 SPECIFICATIONS

ENGINE PERFORMANCE CURVES (Z250-A1 ~ A4)

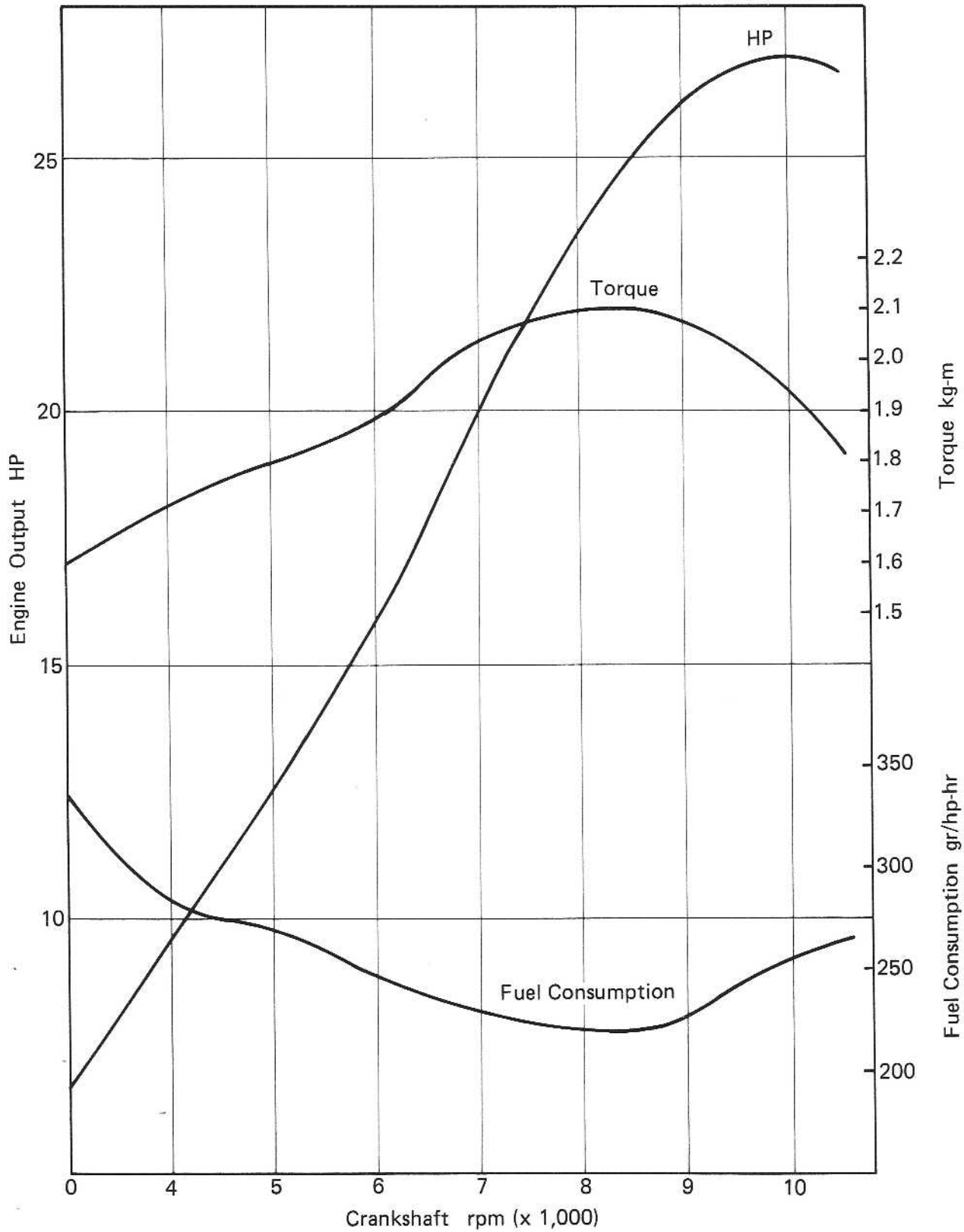

RUNNING PERFORMANCE CURVES (Z250-A1 ~ A4, B1 ~ B3)

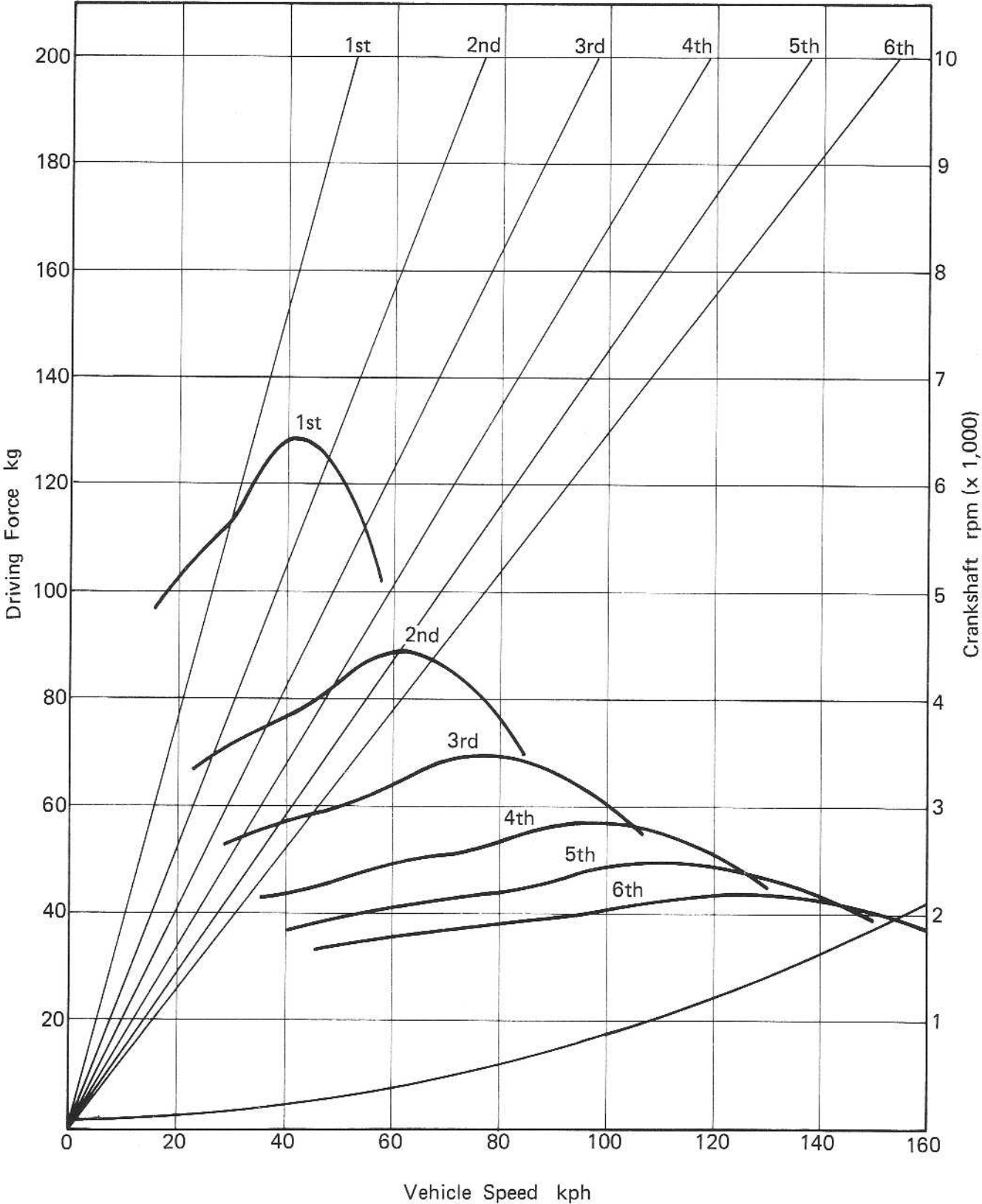

10 SPECIFICATIONS

PERIODIC MAINTENANCE CHART (Z250-A1, A2)

| OPERATION | FREQUENCY | ODOMETER READING * km | | | | | | | See Page |
|---|--------------|-----------------------|-------|--------|--------|--------|--------|--------|----------|
| | | 800 | 5,000 | 10,000 | 15,000 | 20,000 | 25,000 | 30,000 | |
| Battery electrolyte level – check † | Every month | • | • | • | • | • | • | • | 156 |
| Brake adjustment – check † | | • | • | • | • | • | • | • | 25 |
| Brake wear – check † | | | • | • | • | • | • | • | 145~150 |
| Brake fluid level – check † | month | • | • | • | • | • | • | • | 145 |
| Brake fluid – change | year | | | • | | • | | • | 145 |
| Clutch – adjust | | • | • | • | • | • | • | • | 20 |
| Carburetors – adjust | | • | • | • | • | • | • | • | 18 |
| Throttle cables – adjust | | • | • | • | • | • | • | • | 17 |
| Steering play – check † | | • | • | • | • | • | • | • | 26 |
| Drive chain wear – check † | | | • | • | • | • | • | • | 144 |
| Front fork – inspect/clean | | • | • | • | • | • | • | • | 151 |
| Rear shock absorbers – inspect | | • | • | • | • | • | • | • | 24 |
| Nuts, Bolts, Fasteners – check and torque | | • | | • | | • | | • | 34 |
| Spark plugs – clean and gap † | | • | • | • | • | • | • | • | 12 |
| Camshaft chain – adjust | | • | • | • | • | • | • | • | 16 |
| Points, timing – check † | | • | • | • | • | • | • | • | 12 |
| Valve clearance – check † | | • | • | • | • | • | • | • | 16 |
| Air cleaner element – clean | | | • | | • | | • | | 115 |
| Air cleaner element – replace | 5 cleanings | | | • | | • | | • | 115 |
| Fuel system – clean | | • | • | • | • | • | • | • | 22 |
| Tire tread wear – check † | | | • | • | • | • | • | • | 140 |
| Engine oil – change | year | • | • | • | • | • | • | • | 22 |
| Oil filter – change | | • | | • | | • | | • | 22 |
| General lubrication – perform | | | • | • | • | • | • | • | 29 |
| Front fork oil – change | | | | • | | • | | • | 152 |
| Timing advancer – lubricate | | | | • | | • | | • | 162 |
| Swing arm – lubricate | | | | • | | • | | • | 30 |
| Wheel bearings – grease | 2 years | | | | | • | | | 143 |
| Speedometer gear housing – grease | 2 years | | | | | • | | | 89 |
| Steering stem bearings – grease | 2 years | | | | | • | | | 150 |
| Drive chain – lubricate | Every 300 km | | | | | | | | 144 |
| Drive chain – adjust | Every 800 km | | | | | | | | 24 |

* For higher odometer readings, repeat at the frequency interval established here.

† Replace, add or adjust if necessary.

Adjustment—Engine

Table of Contents

B

| | |
|--------------------------------------|----|
| SPARK PLUGS. | 12 |
| IGNITION TIMING | 12 |
| Point Gap Adjustment. | 12 |
| Dwell Angle Adjustment | 13 |
| Static Ignition Timing | 13 |
| Dynamic Ignition Timing | 15 |
| CAMSHAFT CHAIN. | 16 |
| VALVE CLEARANCE | 16 |
| THROTTLE CABLES. | 17 |
| CARBURETORS | 18 |
| Idling Adjustment | 19 |
| Carburetor Synchronization | 19 |
| CLUTCH. | 20 |
| ENGINE OIL | 21 |
| Oil Level | 21 |
| Oil and Oil Filter Change. | 22 |
| FUEL SYSTEM | 22 |

12 ADJUSTMENT—ENGINE

SPARK PLUGS

Neglecting the spark plugs eventually leads to difficult starting and poor performance. During normal operation, the electrodes gradually burn away and carbon builds up along the insulator. In accordance with the Periodic Maintenance Chart (Pg. 10), the plugs should be removed for inspection, cleaning, and to reset the gaps.

- Remove the spark plugs using a spark plug wrench.
- Clean the spark plugs, preferably in a sand-blasting device, and then clean off any abrasive particles. The plug may also be cleaned using a high flash-point solvent and a wire brush or other suitable tool. If the spark plug electrodes are corroded or damaged, or if the insulator is cracked, replace the plug. Use the standard plug or its equivalent.
- Measure the spark plug gaps with a thickness gauge. If the gap is incorrect, carefully bend the side electrode with a suitable tool to obtain the correct gap.

Spark Plug Gap

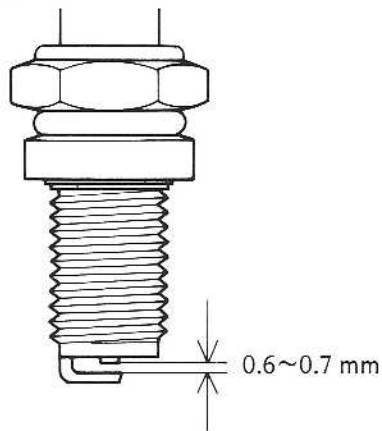

B1

Table B1 Spark Plugs

| | |
|-------------------|--|
| Type | NGK D8EA or ND X24ES-U (E) NGK DR8ES or ND X24ESR-U |
| Gap | 0.6~0.7 mm |
| Tightening Torque | 2.0 kg-m (14.5 ft-lbs) |

(E) : European model except Italian model

- Screw the spark plugs into the cylinder head and tighten them to the specified torque. Connect the spark plug leads.

NOTE: Refer to the electrical maintenance section, Pg. 163, for detailed spark plug information.

IGNITION TIMING

Incorrect ignition timing can cause poor performance, knocking, overheating, and serious engine damage. Periodic adjustment will be necessary to compensate for wear of parts, and the ignition timing must be checked whenever ignition related parts have been disassembled or replaced.

Correct ignition timing is achieved by first obtaining the correct contact breaker point gap (this can also be achieved by adjusting the dwell angle to the specified

amount) and then changing the position of the contact breaker mounting plate. Setting the points often returns the timing very close to the correct setting. Once the timing has been adjusted, it may be checked for accuracy by the use of a strobe light.

There are two sets of contact breaker points: the left set marked "L" fires the spark plug on the left, and the right set marked "R" fires the spark plug on the right 180° later. The gap for each set of points must be adjusted separately.

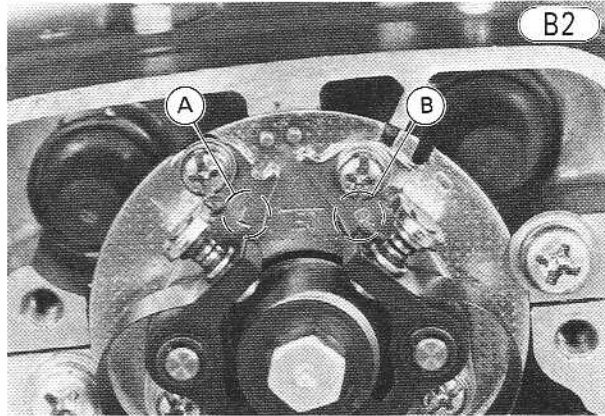

A. L Mark

B. R Mark

There are two sets of timing marks on the rotor. One set marked "1" or "L" is for timing the left cylinder, and the other set marked "2" or "R" is for timing the right cylinder. The "F" mark of each set is for checking the timing before advancing, and the "advanced timing marks" (a pair of lines) are for checking the timing after it has advanced.

Timing Marks

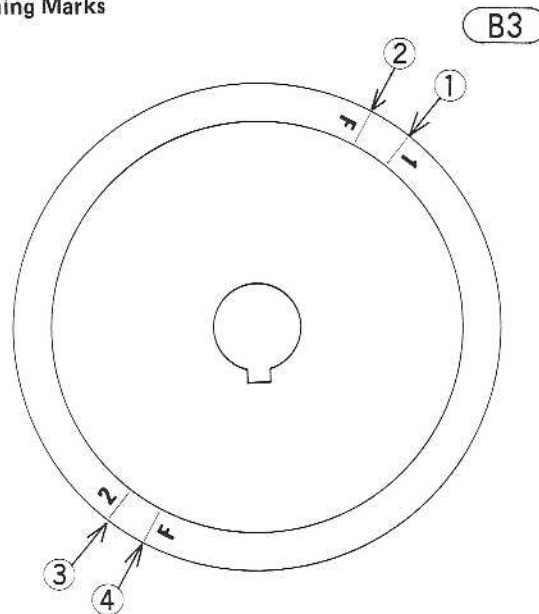

1. Left Cylinder TDC Mark
2. Left Cylinder "F" Mark
3. Right Cylinder TDC Mark
4. Right Cylinder "F" mark

Point Gap Adjustment

- Remove the contact breaker cover and gasket.
- Remove the alternator cover.

- Clean the points with a piece of clean paper or cloth using an oil-free solvent. A business card soaked in trichloroethylene can be used to remove traces of oil. To repair light damage, use emery cloth or an oilstone. If the points are badly worn down or damaged, or if the spring is weak, replace the contact breaker.
- Lubricate the point cam felt sparingly with suitable point cam lubricant. Do not overlubricate. Replace the felt if it is worn.
- Using a 14 mm wrench on the crankshaft, turn the engine counterclockwise until the contact breaker points are at their widest opening.
- Measure the contact breaker point gap with a thickness gauge. The proper gap is 0.3~0.4 mm.
- If the gap is incorrect, loosen the contact breaker base screws (2) just enough to allow the base to move. Use a slot screwdriver on the pry points until the correct point gap is obtained. Tighten the screws.

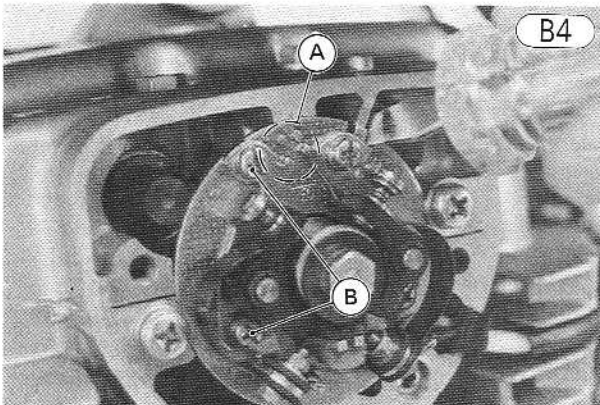

A. Pry Points B. Base Screws

- Turn the crankshaft until the other point gap is opened, and adjust it if necessary.
- Adjust the ignition timing.

Dwell Angle Adjustment

The most precise means to set the point gap is to use a dwell angle tester instead of a thickness gauge. If a dwell angle tester is available, adjust the dwell angle (point gap) in the following manner.

NOTE: The dwell angle is the angular range for which the contact breaker points are closed. This allows the current to flow in the ignition coil primary winding.

WARNING To prevent an injury when measuring the dwell angle, make sure that no tools, clothes, or tester leads touch the spinning camshaft.

- Remove the contact breaker cover and gasket.
- Clean the points with a piece of clean paper or cloth using an oil-free solvent. A business card soaked in trichloroethylene can be used to remove traces of oil. To repair light damage, use emery cloth or an oilstone. If the points are badly worn down or damaged, or if the spring is weak, replace the contact breaker.
- Lubricate the point cam oil felt sparingly with suitable point cam lubricant. Do not overlubricate. Replace the oil felt if it is worn.
- Connect the dwell angle tester (–) lead to chassis ground and the (+) lead to the contact breaker spring.

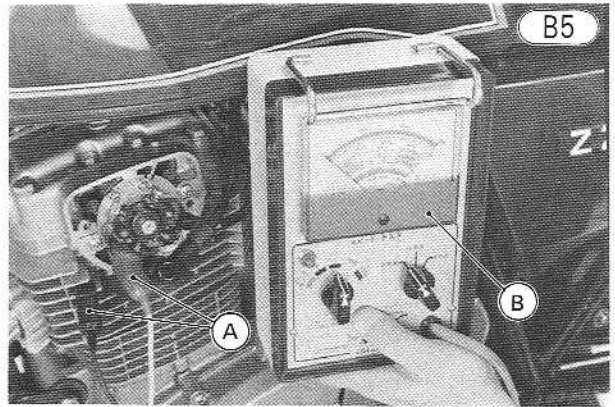

A. Tester Leads B. Dwell Angle Tester

- If the dwell angle tester is calibrated in degrees, turn the selector knob to the lowest cam lobe setting.
- Start the engine and let it idle.
- Note the reading on the tester. The dwell angle specification is 97°~112° for a tester calibrated in degrees and 27~31% for one calibrated in percentage. If the tester setting is for two cylinders, the reading must be doubled to obtain the true dwell angle.

Table B2 Dwell Angle

| Selector Knob Setting | Dwell Angle |
|-----------------------|-------------|
| 1 Cylinder | 97° ~ 112° |
| 2 Cylinders | 48.5° ~ 56° |

- If the dwell angle is incorrect, loosen the contact breaker base screws (2) just enough to allow the base to move. Use a slot screwdriver on the pry points until the correct dwell angle is obtained. Tighten the screws.
- Check the dwell angle for the other contact breaker, and adjust it if necessary.
- Stop the engine and disconnect the tester leads.
- Adjust the ignition timing.

Static Ignition Timing

Check and adjust the static ignition timing for both cylinders using each "F" mark, first for the left cylinder and then the right cylinder.

- Turn off the ignition switch and engine stop switch.
- Remove the inlet valve adjusting cap on the left cylinder.

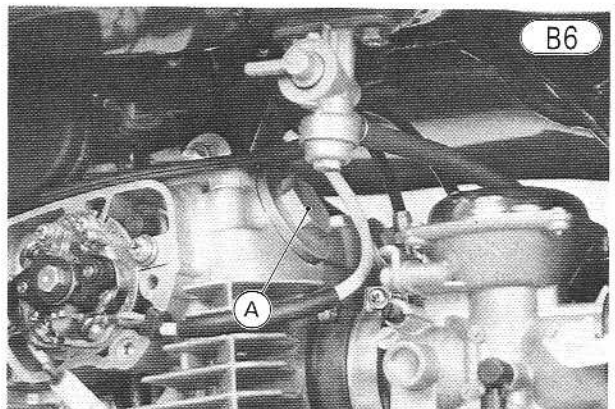

A. Inlet Valve Adjusting Cap

14 ADJUSTMENT—ENGINE

- Connect a timing tester or circuit tester across the left-hand set of contact breaker points by securing one lead to the contact breaker spring or lead, and the other lead to the chassis ground.

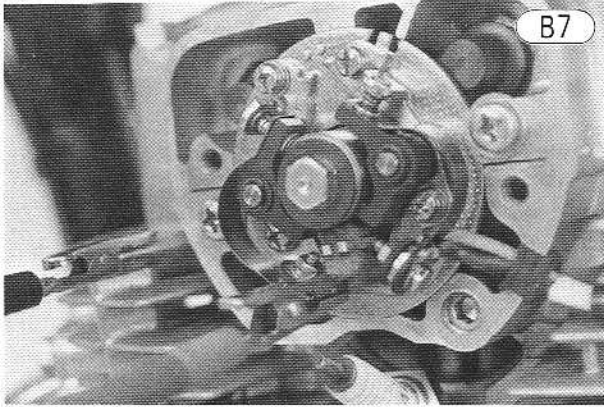

- Using a 14 mm wrench, turn the crankshaft counterclockwise until the inlet valve rocker arm on the left cylinder goes downward (valve opening) and returns upward (valve closing).

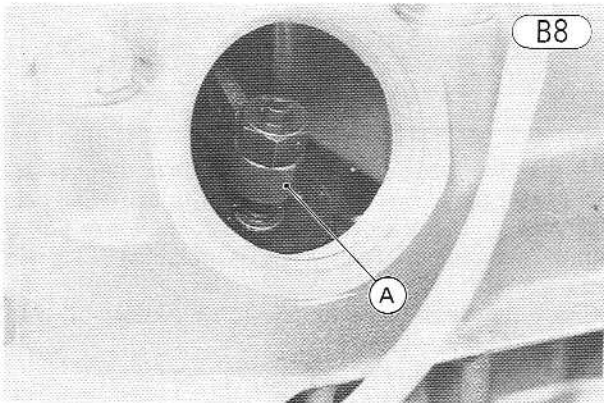

A. Rocker Arm

- Continue turning the crankshaft counterclockwise another half turn so that the "F" mark near the number "1" or "L" on the rotor is aligned with the timing mark on the left engine cover.

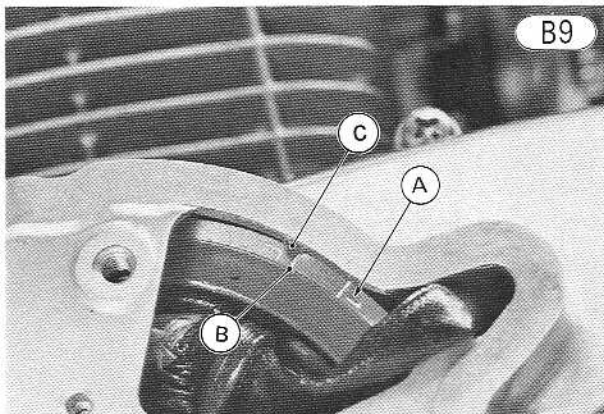

A. Number "1" or "L"
B. "F" Mark
C. Timing Mark

- The circuit tester needle should flicker when the "F" mark and timing mark are aligned, indicating that the points have just opened. When using an audible timing tester, there should be a change in tone of the tester at this point.
- If the timing is not correct, loosen the mounting screws (2), and use a slot screwdriver on the pry points to adjust the mounting plate. Tighten the screws securely and recheck the timing.

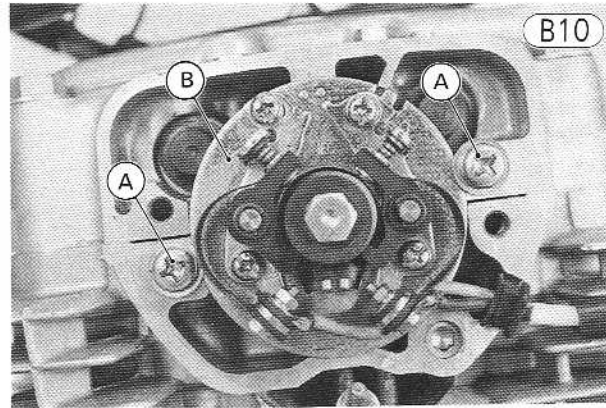

A. Mounting Screws (2)
B. Mounting Plate

- Move the tester leads to the right-hand set of points to check the ignition timing for the right cylinder.
- Turn the crankshaft counterclockwise a half turn so that the "F" mark near the number "2" or "R" on the rotor is aligned with the timing mark on the left engine cover.

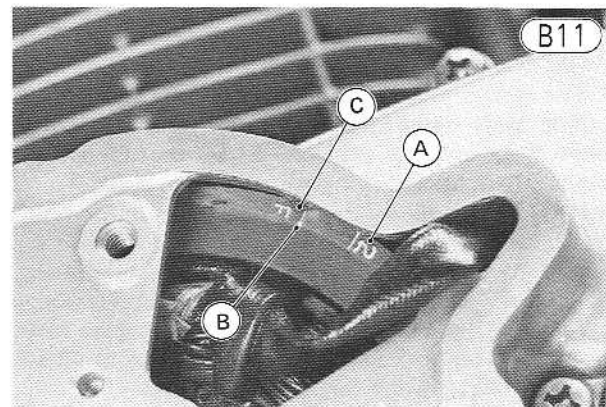

A. Number "2" or "R"
B. "F" Mark
C. Timing Mark

- If the circuit tester needle does not flicker when the "F" mark and timing mark are aligned, loosen the base screws (2) on the right contact breaker and adjust the point gap to within its specification (0.3~0.4 mm) until the correct ignition timing is obtained.

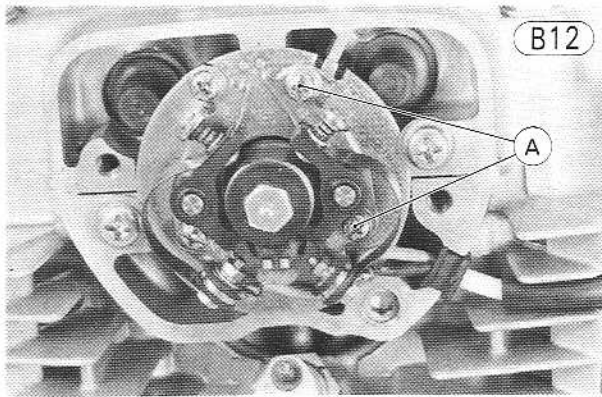

A. Base Screws

- If the correct ignition timing for the right cylinder cannot be obtained by adjusting the right contact breaker point gap, adjust the right contact breaker point gap to 0.35 mm, and adjust the ignition timing for the right cylinder by shifting the mounting plate position.
- Recheck the left contact breaker point gap and the ignition timing for the left cylinder. Readjust if necessary.
- If these adjustments resulted in failure, the contact breakers have worn out, and both must be replaced with new ones.
- Disconnect the tester leads and install the contact breaker cover.

Dynamic Ignition Timing

- Connect the strobe light lead to the left spark plug lead in order to check the ignition timing for the left cylinder under operating conditions. One example of the wiring is shown below.

Dynamic Ignition Timing Test

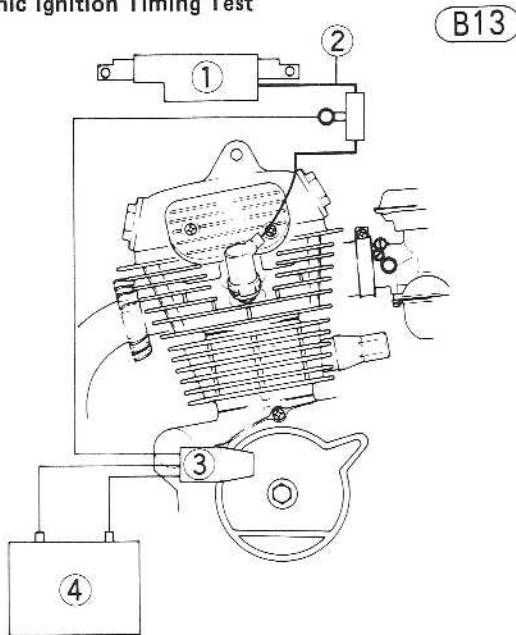

- 1. Ignition Coil
- 2. Spark Plug Lead
- 3. Strobe Light
- 4. Battery

- Prepare a cloth or rags as a small amount of oil may splash or spill out of the crankcase during engine operation without the alternator cover.

- Turn on the ignition switch and engine stop switch. Start the engine and warm it up thoroughly. Then, direct the strobe light at the timing mark.
- At idle, the "F" mark near the number "1" or "L" on the rotor must be aligned with the timing mark on the left engine cover for correct low rpm ignition timing. If the timing is not correct, adjust it by moving the mounting plate.

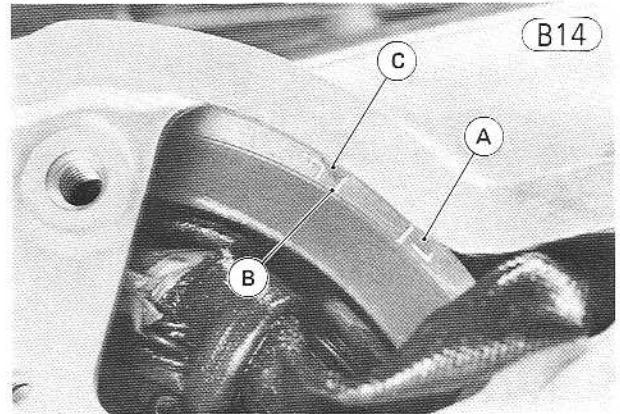

- A. Number "1" or "L"
- B. "F" Mark
- C. Timing Mark

- At 3,200 rpm or higher, the advanced timing marks must be aligned with the timing mark for correct high rpm ignition timing. If the timing is not correct, examine the timing advancer mechanism for binding.

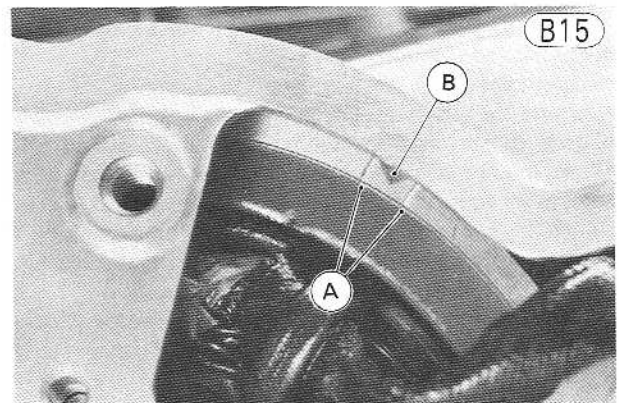

- A. Advanced Timing Marks
- B. Timing Mark

Table B3 Timing Advancing

| | Engine Speed (rpm) |
|----------------|--------------------|
| Advance Begins | 1,300~1,660 |
| Full Advance | 2,800~3,200 |

- Next, move the strobe light lead to the right spark plug lead, and check the ignition timing for the right cylinder using the other "F" mark. Adjust the contact breaker point gap on the right, if necessary.
- Disconnect the strobe light lead, clean up any spilled oil, and install the alternator cover.

16 ADJUSTMENT—ENGINE

CAUTION Before installing the screws, place the O rings under the screw heads to prevent O ring damage and resulting oil leakage.

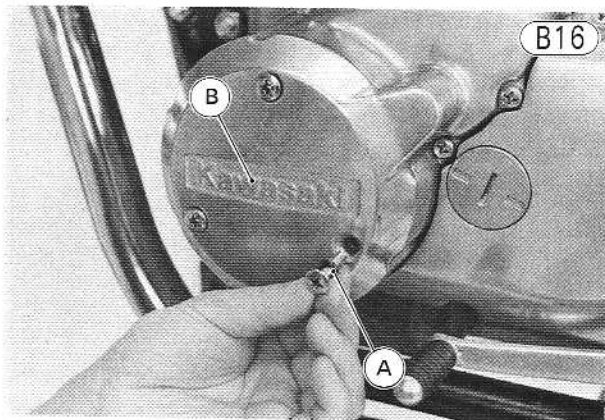

A. O Ring B. Alternator Cover

CAMSHAFT CHAIN

Camshaft chain and chain guide wear cause the chain to develop slack, which will cause noise and may result in engine damage. To keep the chain from making noise, periodic adjustment is necessary in accordance with the Periodic Maintenance Chart (Pg. 10).

However, if the adjustment fails to keep the chain from making noise, the camshaft chain or chain guides have probably worn past their service limits and will need to be replaced.

WARNING To avoid a serious burn, never touch a hot engine or exhaust pipes during camshaft chain adjustment.

- Remove the chain tensioner cap and O ring.
- Remove the alternator cover.
- Check to see that the ignition switch is turned off.
- Turn the crankshaft counterclockwise while watching the push rod (in the center of the push rod guide) move in and out. Continue turning the crankshaft counterclockwise until the push rod again reaches the innermost position, and then stop.

NOTE: Do not turn the crankshaft backwards (clockwise). Turning the crankshaft backwards may cause improper adjustment.

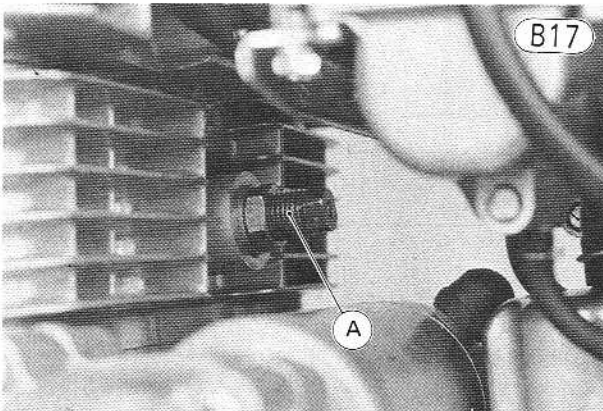

A. Camshaft Chain Tensioner

- Loosen the locknut, and turn in the push rod guide carefully until the ends of the push rod guide and push rod are flush.

CAUTION Be sure that the ends are flush. Never overtighten the push rod guide after the ends are just flush, or the tensioner and chain may become damaged.

Camshaft Chain Tensioner

B18

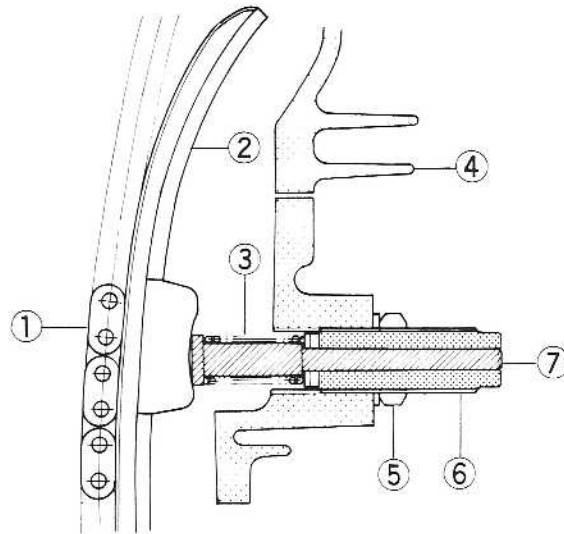

- | | |
|-------------------|-------------------|
| 1. Camshaft Chain | 5. Locknut |
| 2. Chain Guide | 6. Push Rod Guide |
| 3. Spring | 7. Push Rod |
| 4. Cylinder Block | |

- Tighten the locknut to 1.5 kg-m (11 ft-lbs) of torque.
- Install the chain tensioner cap with its O ring and tighten it to 1.5 kg-m (11.0 ft-lbs) of torque.
- Install the alternator cover.

CAUTION Before installing the screws, place the O rings under the screw heads to prevent O ring damage and resulting oil leakage.

VALVE CLEARANCE

Valve and valve seat wear decreases the valve clearance, upsetting the valve timing. If the valve clearance is left unadjusted, the wear will eventually cause the valves to remain partly open; which lowers performance, burns the valves and valve seats, and may cause serious engine damage.

The valve clearance for each valve should be checked and adjusted, in accordance with the Periodic Maintenance Chart (Pg. 10) and any time that the clearance may have been affected by disassembly.

Be careful to adjust within the specified clearance. Adjusting to a larger value will disturb valve timing and cause engine noise.

NOTE: The valve clearance must be checked when the engine is cold.

- Remove the fuel tank (Pg. 39).
- Remove the valve adjusting caps (4).

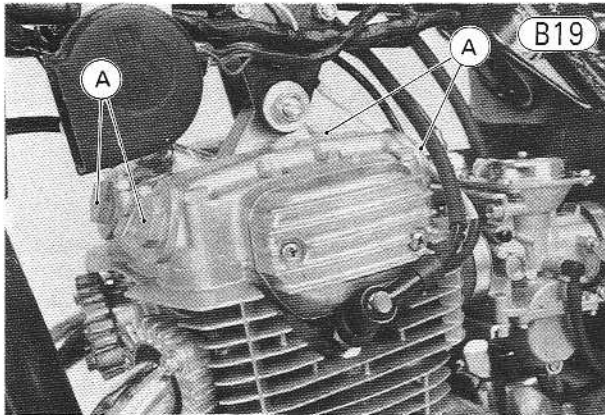

A. Valve Adjusting Caps

- Remove the screws (3), and remove the alternator cover.
- Using a 14 mm wrench, turn the crankshaft counterclockwise until the inlet valve rocker arm on the left cylinder goes downward (valve opening) and returns upward (valve closing).

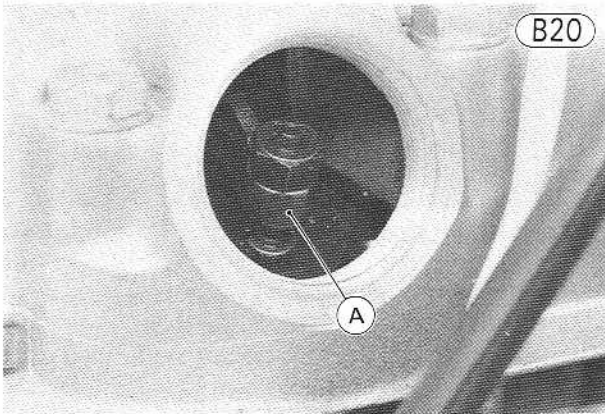

A. Rocker Arm

- Continue turning the crankshaft counterclockwise another half turn so that the TDC mark near the mark "1" or "L" on the rotor is aligned with the timing mark on the left engine cover.

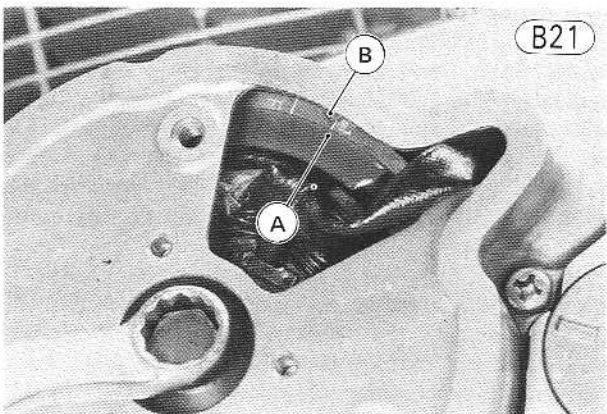

A. TDC Mark

B. Timing Mark

- At this crankshaft position, the piston in the left cylinder is at the end of its compression stroke and the inlet and exhaust valves for the left cylinder can be checked.
- Measure the clearance of each valve by inserting a thickness gauge (special tool) between the adjusting screw and the valve stem.

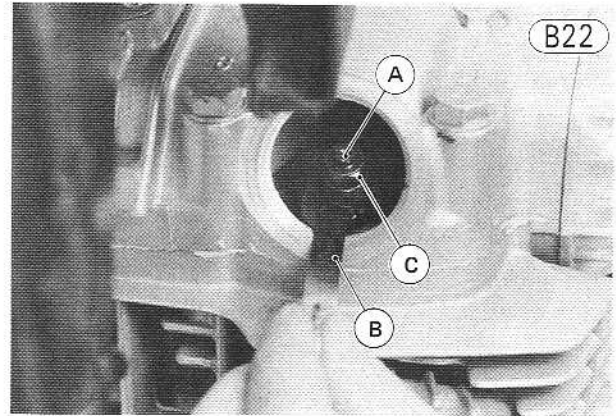

A. Adjusting Screw

C. Locknut

B. Thickness Gauge (57001-1081)

Table B4 Valve Adjustment (When cold)

| | | |
|---------------------------|---------|---------------------------|
| Valve Clearance | Inlet | 0.14~0.19 mm |
| | Exhaust | 0.21~0.26 mm |
| Locknut Tightening Torque | | 1.5 kg-m (11.0 ft-lbs) |

- If the valve clearance is incorrect, loosen its adjusting screw locknut, and turn the adjusting screw until the correct clearance is obtained.
 - Tighten the locknut to the specified torque.
 - Turn the crankshaft counterclockwise a half turn so that the TDC mark near the mark "2" or "R" on the rotor is aligned with the timing mark on the left engine cover. Check the valve clearances on the right cylinder, and adjust them if necessary.
 - Install the valve adjusting caps.
 - Install the alternator cover.
- CAUTION** Before installing the screws, place the O rings under the screw heads to prevent O ring damage and resulting oil leakage.
- Install the fuel tank (Pg. 39).

THROTTLE CABLES

There are two throttle cables: an accelerator cable for opening the butterfly valves, and a decelerator cable for closing them. If the cables are too loose due to either cable stretch or maladjustment, the excessive play in the throttle grip will cause a delay in throttle response, which will be especially noticeable at low

18 ADJUSTMENT—ENGINE

rpm. Also, the butterfly valves may not open fully at full throttle. On the other hand, if the cables are too tight, the throttle will be hard to control, and the idle speed will be erratic.

To check the throttle cable adjustment:

- Check that there is 2~3 mm throttle grip play.

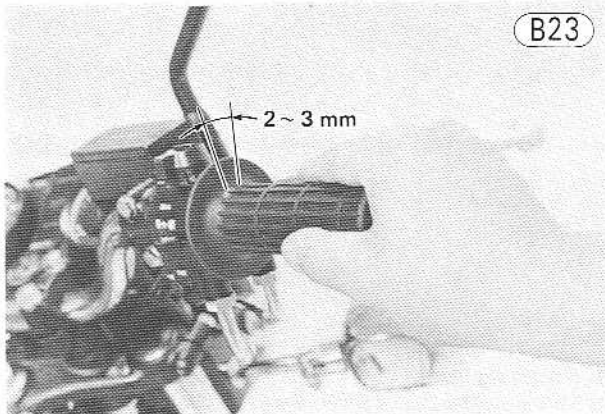

- Push the throttle grip completely closed. At this time the decelerator throttle cable bracket should be pushed down 1~2 mm. When the throttle grip is released, the cable bracket should be returned to its rest position by the spring tension.

NOTE: This assures that the stress of throttle grip return will be taken by the throttle grip, protecting the carburetor linkage mechanism.

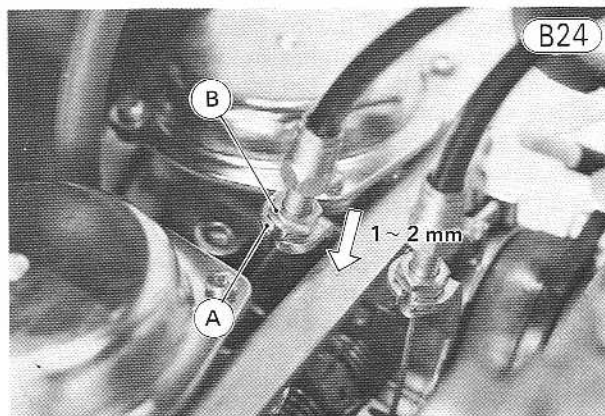

A. Decelerator Throttle Cable Bracket B. Locknut

If any one of the above checks shows improper adjustment, adjust the throttle cables as follows:

- Loosen the locknuts, and screw both throttle cable adjusting nuts in fully at the upper end of the throttle cables so as to give the throttle grip plenty of play.
- Turn out the decelerator cable adjusting nut until the cable bracket is pushed down 1~2 mm when the throttle grip is completely closed. Tighten the locknut.

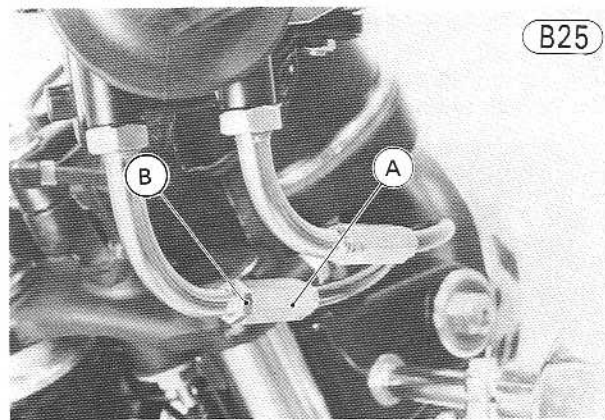

A. Decelerator Cable Adjusting Nut B. Locknut

- Turn the accelerator cable adjusting nut until 2~3 mm of throttle grip play is obtained. Tighten the locknut.

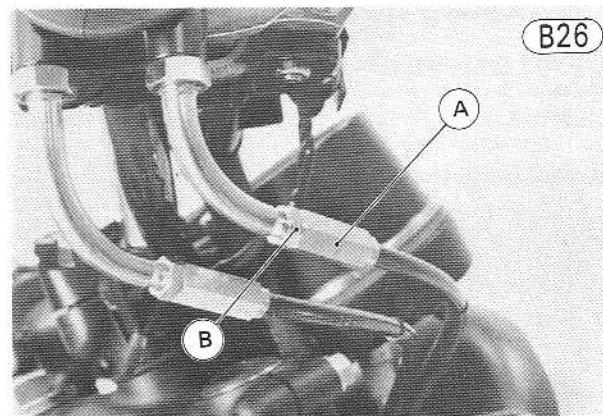

A. Accelerator Cable Adjusting Nut B. Locknut

NOTE: If the throttle cables cannot be adjusted by using the cable adjusting nuts at the upper end of the throttle cables, use the cable adjusters at the lower ends of the throttle cables. Do not forget to securely tighten the adjusting locknuts.

CARBURETORS

Although some internal carburetor parts can be adjusted by replacement, repositioning, etc., these adjustments are covered in the maintenance section of this manual. The following procedure covers the idling adjustment, which is the adjustment necessary for periodic maintenance and whenever the idle setting has been disturbed. This procedure also includes the necessary steps for obtaining proper carburetor synchronization.

When the idle speed is too low, the engine may stall. When the idle speed is too high, fuel consumption will be excessive, and the resulting lack of engine braking may make the motorcycle difficult to control. Poor carburetor synchronization causes unstable idling, sluggish throttle response, and reduced engine power and performance.

Idling Adjustment:

- Start the engine and warm it up for five minutes.
- Turn the idle adjusting screw until the engine is at the lowest smooth rpm.
- Adjust the pilot screw of each carburetor, one at a time, to obtain highest idle speed. This pilot screw adjustment will be within ½ turn in or out from the specified setting.

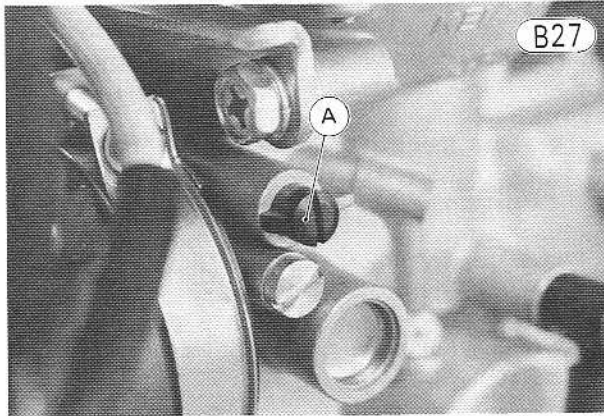
**A. Pilot Screw**

- Turn the idle adjusting screw to set idle speed to 1,200 ~ 1,300 rpm.
- Make sure that engine rpm does not rise when the pilot screw positions are altered. If it does, repeat the last three steps.
- Open and close the throttle a few times to make sure that the idle speed does not change. Readjust if necessary.
- With the engine idling, turn the handlebar to each side. If handlebar movement changes idle speed, the throttle cables may be improperly adjusted or incorrectly routed, or they may be damaged.

WARNING Operation with improperly adjusted, incorrectly routed, or damaged cables could result in an unsafe riding condition.

NOTE: If idling adjustment has resulted in failure, check the following and correct if necessary.

- Carburetor Function Checks (Pg. 42)
- Engine Oil (Pg. 21)
- Spark Plugs (Pg. 12)
- Ignition Timing (Pg. 12)
- Throttle Cables (Pg. 17)
- Cylinder Compression (Pg. 127)
- Air Cleaner Element (Pg. 115)
- Camshaft Chain (Pg. 16)
- Valve Clearance (Pg. 16)

Carburetor Synchronization:

Adjustment of carburetor synchronization, necessary for smooth engine operation, can be obtained through the use of either of the following two procedures, depending on whether or not vacuum gauges are available.

NOTE: During both of the procedures, the fuel tank will be removed. In most cases, it will be necessary to temporarily replace the standard fuel lines with lines

long enough to reach the fuel tank while it is located on your workbench.

WARNING Use extreme caution when working with gasoline, open fuel lines, etc. to avoid a fire or explosion.

Without Vacuum Gauges:

- Start the engine, and warm it up for 5 minutes.
- Perform the idling adjustment.
- Listen to the exhaust noise, and place your hands at the rear of the mufflers to feel exhaust pressure.

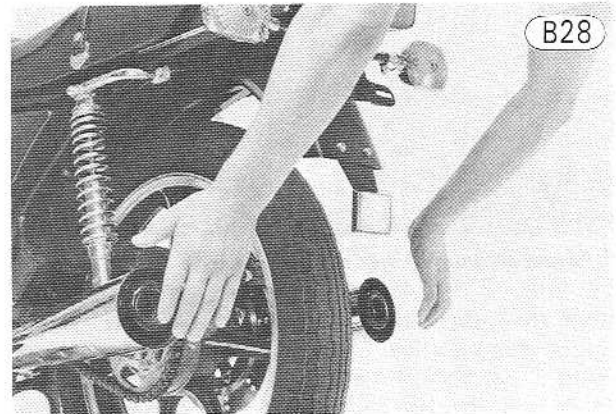

- If there is a difference in noise or exhaust pressure between the cylinders, stop the engine, remove the fuel tank (Pg. 39), and supply fuel to the carburetors by some means. With the engine running, alter the balance adjusting screw position with the balance adjuster (special tool) to minimize the difference in noise or exhaust pressure.

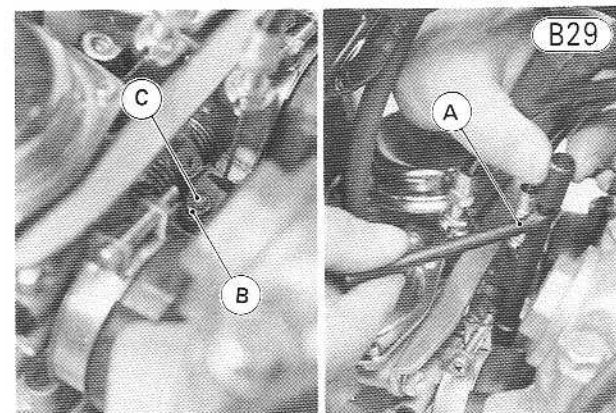

A. Balance Adjuster (57001-351)
B. Locknut
C. Balance Adjusting Screw

- Adjust the idle speed with the idle adjusting screw, if necessary.
- Recheck the exhaust noise and pressure, and if there is a difference between the cylinders, repeat the last 2 steps.
- When the balance adjusting screw is properly positioned, tighten the locknut, stop the engine, and install the fuel tank (Pg. 39).

20 ADJUSTMENT—ENGINE

With Vacuum Gauges:

- Start the engine, and warm it up for 5 minutes.
- Perform the idling adjustment (Pg. 19).
- Remove the vacuum plug from each carburetor, and attach the vacuum gauges and adapters (special tools).

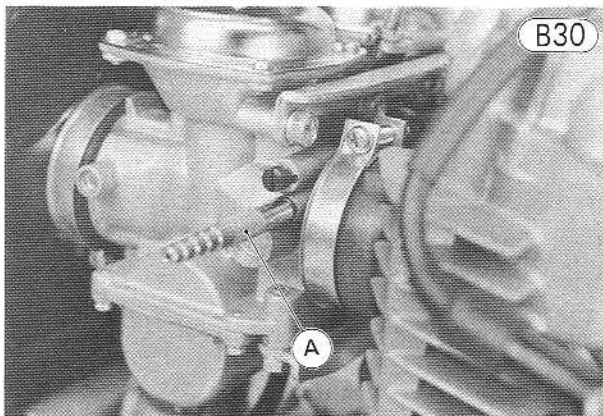

A. Vacuum Gauge Adapter (57001-401)

- With the engine running at idle speed, close the vacuum gauge damper valves until gauge needle flutter is less than 3 cm Hg. Normal vacuum gauge reading is 19 ~ 26 cm Hg, and the difference between the two cylinders should be less than 3 cm Hg.

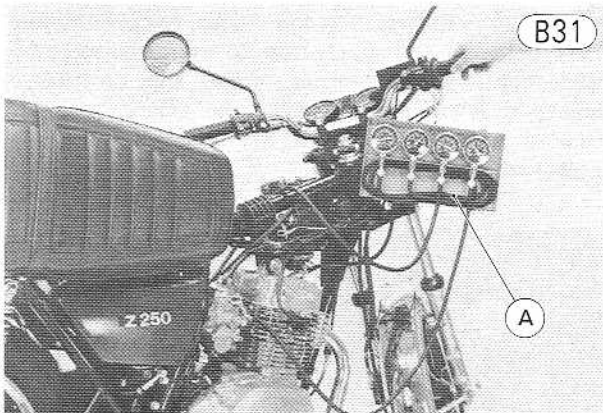

A. Vacuum Gauge Set (57001-127)

- If there is a difference of more than 3 cm Hg between the two gauges, stop the engine, remove the fuel tank (Pg. 39), and supply fuel to the carburetors by some means.
- With the engine running, alter the balance adjusting screw position with the balance adjuster (special tool) to obtain a difference in readings of less than 3 cm Hg.
- Adjust the idle speed with the idle adjusting screw, if necessary.
- Recheck the difference in vacuum gauge readings, and if there is a difference of more than 3 cm Hg, repeat the last 2 steps.
- When the balance adjusting screw is properly positioned, tighten the balance adjusting screw locknut and stop the engine.
- Detach the vacuum gauges and adapter, and install the vacuum plugs.
- Install the fuel tank (Pg. 39).

CLUTCH

Stretching of the clutch cable causes the clutch lever to develop excessive play. Too much play will prevent complete disengagement and may result in shifting difficulty and possible clutch and transmission damage. Most of the play must be taken up, but a small amount must remain so that the clutch release lever will function properly.

Clutch plate wear also causes the clutch to go out of adjustment. This wear causes the play between the push rod and the adjusting screw to gradually diminish until the push rod touches the adjusting screw. When this play is lost, the clutch will not engage fully, causing the clutch to slip.

NOTE: Even though the proper amount of play exists at the clutch lever, clutch lever play alone cannot be used to determine whether or not the clutch requires adjustment.

The adjustment procedure which follows compensates for both cable stretch and plate wear.

WARNING To avoid a serious burn, never touch the hot engine or exhaust pipes during clutch adjustment.

To adjust the clutch:

- Turn in fully the locknut and adjusting nut in the middle of the clutch cable. This assures plenty of cable play and proper clutch release angle.

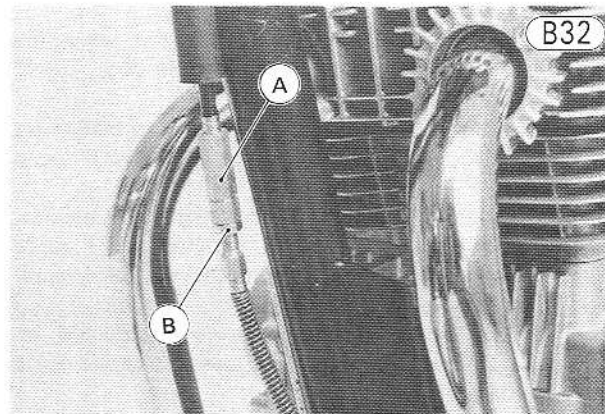

A. Adjusting Nut

B. Locknut

- Loosen the knurled locknut at the clutch lever, and turn the adjuster so that there is a 5 ~ 6 mm gap between the adjuster and knurled locknut.

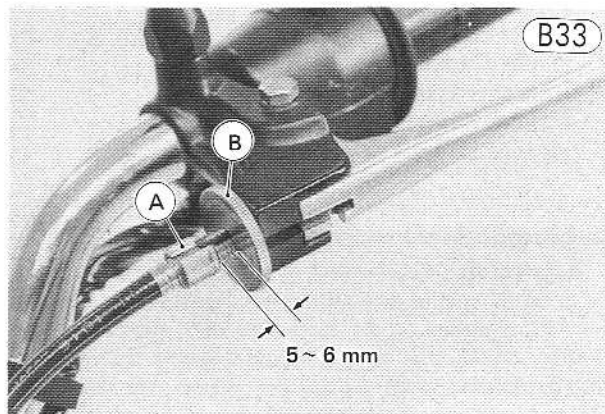

A. Adjuster

B. Knurled Locknut

- Remove the clutch adjusting cover.
- Loosen the locknut, and turn in the adjusting screw a couple of turns.
- **Turn out** the adjusting screw until it seats lightly. This is the point where the clutch is just starting to release.
- **Turn in** the adjusting screw $\frac{1}{4}$ turn from that point, and tighten the locknut without changing the adjusting screw position.

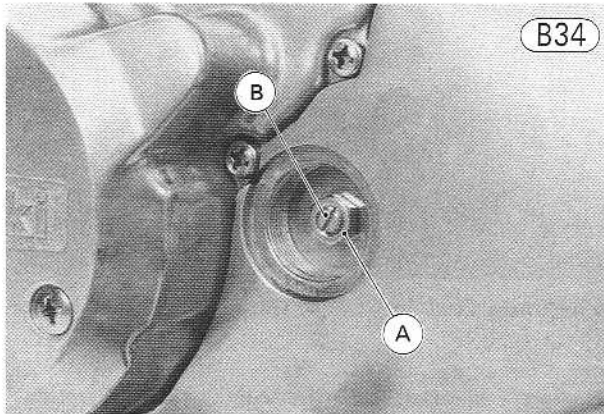

A. Locknut B. Adjusting Screw

- Take up all the cable play with the adjusting nut in the middle of the cable, and tighten the locknut.
- Make sure the lower end of the clutch outer cable is properly fitted into the hole in the engine sprocket cover.

WARNING If the cable is not fully seated in the engine sprocket cover hole, it could slip into place later and the clutch would not disengage.

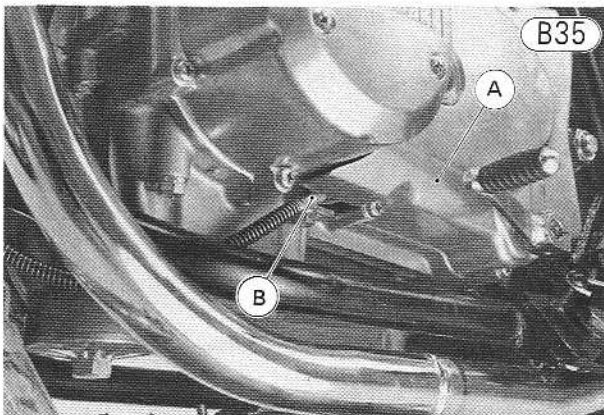

A. Engine Sprocket Cover B. Clutch Outer Cable

- Turn the adjuster at the clutch lever until the clutch lever has 2~3 mm of play. Tighten the locknut.

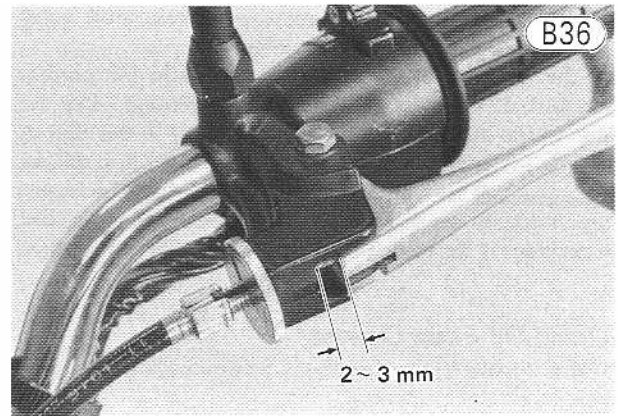

- Install the clutch adjusting cover.

ENGINE OIL

In order for the engine, transmission, and clutch to function properly, maintain the engine oil at the proper level, and change the oil in accordance with the Periodic Maintenance Chart (Pg. 10).

WARNING Motorcycle operation with insufficient, deteriorated, or contaminated engine oil will cause accelerated wear and may result in engine or transmission seizure, and accident and injury.

Oil Level

- Situate the motorcycle so that it is perpendicular to the ground (on its center stand).
- If the oil has just been changed, start the engine and run it for several minutes at idle speed. This fills the oil filter with oil. Then wait several minutes until the oil settles.

CAUTION Run the engine at idle speed for several minutes. Racing the engine before the oil reaches every part can cause engine seizure.

- If the motorcycle has just been used, wait several minutes for all the oil to drain down.
- Check the engine oil level through the oil level gauge in the lower right side of the engine. With the motorcycle held level or on the center stand, the oil level should come up between the lines next to the gauge.

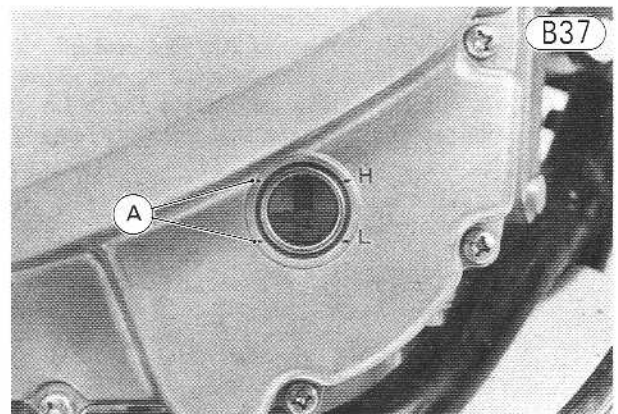

A. Level Lines

22 ADJUSTMENT—ENGINE

- If the oil level is too high, remove the excess oil, using a syringe or some other suitable device.
- If the amount of oil is insufficient, add the correct amount of oil through the oil filler opening. Use the same type and make of oil that is already in the engine.

WARNING If the engine is run without oil, it will be severely damaged. In addition, the engine may suddenly seize, locking the rear wheel and causing an accident if the clutch lever is not pulled in fast enough.

Oil and Oil Filter Change

- Warm up the engine for about 5 minutes and then stop it.
- Set the motorcycle up on its center stand, place an oil pan beneath the engine, and remove the engine oil drain plug.

WARNING When the engine is hot, remove the drain plug carefully so as to not suffer a burn from the hot oil.

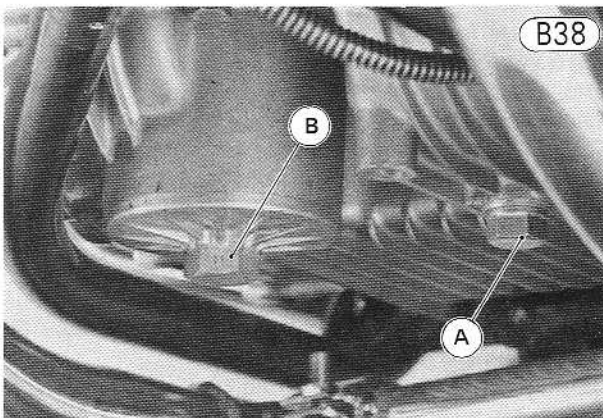

A. Drain Plug B. Oil Filter

- If the oil filter is to be changed, remove the filter and replace the oil filter with a new one.
- NOTE:** Check for O ring damage. If necessary, replace it with a new one.
- After the oil has completely drained out, install the drain plug and gasket, using a new gasket if the old one is deteriorated or damaged. Proper torque for the drain plug is 3.0 kg-m (22 ft-lbs).
 - Install the oil filter, tightening its bolt to 1.5 kg-m (11.0 ft-lbs) of torque.
 - Fill the engine up to the upper level line with SE class SAE 10W40, 10W50, 20W40 or 20W50 motor oil. It will take about 1.8 l when the filter is changed. When the filter is not changed, a refill takes about 1.5 l.
 - Check the oil level again after the engine is thoroughly warmed up.

FUEL SYSTEM

Water or dirt anywhere in the fuel system can cause starting difficulty, poor running, and lack of power.

Clean out the fuel system as follows:

- Turn the fuel tap to the off position. Unscrew the sediment cup at the bottom of the tap, and clean out the water and dirt. Clean any dirt out of the fuel tap filter.

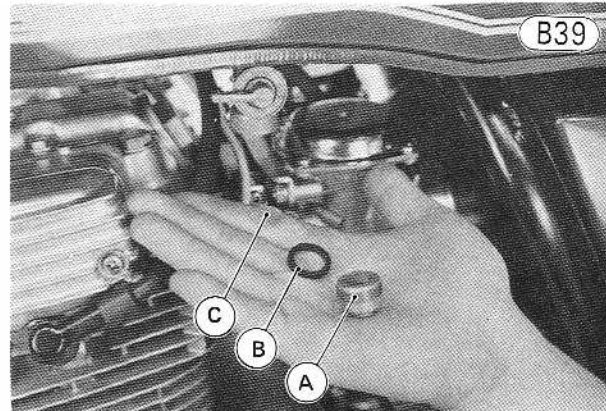

A. Sediment Cup B. Gasket C. Filter

- If there was water inside the sediment cup, there may also be some in the fuel tank and carburetors. Holding a container under the fuel tap, turn the tap to the reserve position to drain the tank until only gasoline comes out, and then close the tap.
- Install the gasket and the sediment cup. Make sure that the gasket is in the tap and that the filter is not damaged during installation.
- Turn the fuel tap to the off position, loosen the drain screws, and drain the fuel in the float bowls through the overflow tubes.
- Tighten the drain screws.

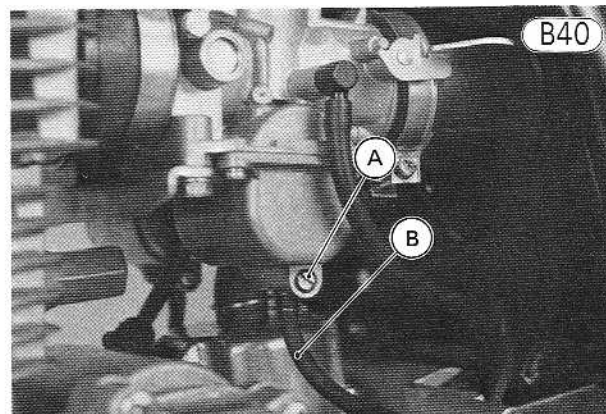

A. Drain Screw B. Overflow Tube

- WARNING**
1. Clean the fuel tap in a well-ventilated area, and take ample care that there are no sparks or flame anywhere near the working area.
 2. Never clean out the fuel tank or tap when the engine is still warm.
 3. Wipe any fuel off the engine before starting it.

Adjustment—Chassis

Table of Contents

C

| | |
|---------------------------------|----|
| REAR SHOCK ABSORBERS..... | 24 |
| DRIVE CHAIN..... | 24 |
| BRAKES (Disc Type)..... | 25 |
| Front Brake..... | 25 |
| Rear Brake..... | 25 |
| BRAKE LIGHT SWITCH..... | 26 |
| STEERING..... | 26 |
| WHEEL BALANCE (Cast Wheel)..... | 27 |
| HEADLIGHT..... | 28 |
| HORN..... | 28 |
| LUBRICATION..... | 29 |

24 ADJUSTMENT—CHASSIS

REAR SHOCK ABSORBERS

The rear shock absorbers can be adjusted to one of five positions to suit riding conditions. They can be left soft for average riding but should be adjusted harder for high speed riding, riding on rough roads, or riding with a passenger. Shock absorbers adjusted either too soft or too hard adversely affect riding comfort and stability.

To adjust the rear shock absorbers:

- Turn the adjusting sleeve on each shock absorber to the desired position with a hook spanner. The higher the adjusting sleeve is positioned, the stronger the spring tension, and the harder the ride.

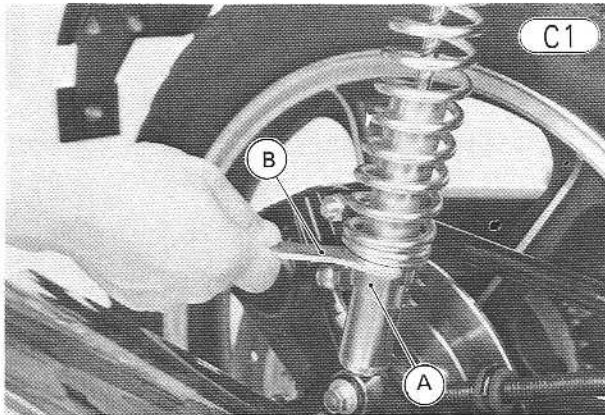

A. Adjusting Sleeve B. Hook Spanner

- Make sure that both adjusting sleeves are turned to the same relative position.

WARNING If the rear shock absorbers are not adjusted equally, handling may be impaired.

DRIVE CHAIN

Chain and sprocket wear causes the chain to stretch, which results in power loss, accelerated chain and sprocket wear, and increased noise. A chain that has been adjusted too loose may be thrown off the sprockets. A chain that has been adjusted too tight will wear excessively and possibly break.

- To determine whether or not the chain requires adjustment, first set the motorcycle up on its center stand. Rotate the rear wheel to find the position where the chain is tightest, and measure the vertical movement midway between the sprockets. If it is less than 25 mm or more than 35 mm, adjust the chain so that the vertical movement will be about 25 ~ 30 mm.

CAUTION 1. A chain worn past the service limit (Pg. 144) must be replaced. Such wear cannot be adequately compensated for by adjustment.

2. Take care not to damage the brake hose. Damaging the brake line greatly reduces the brake line strength and causes brake fluid leakage, resulting in the loss of brake control.

Chain Slack

C2

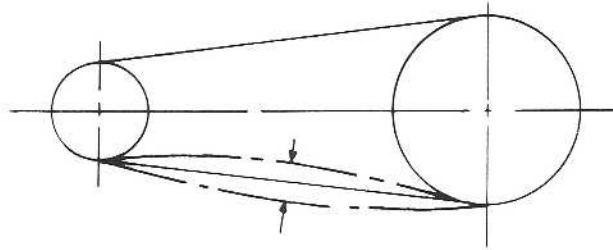

- Loosen the nut at the rear end of the torque link.

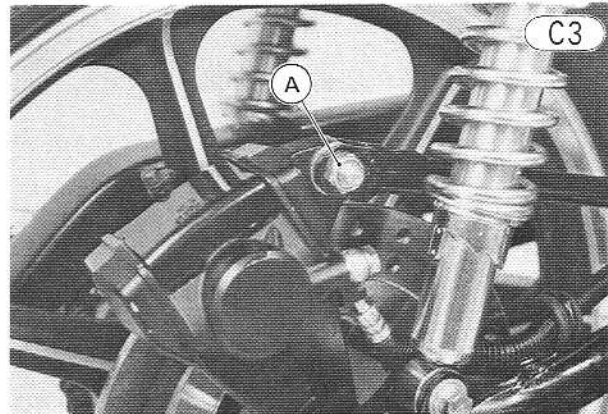

A. Torque Link Nut

- Loosen the left and right chain adjuster locknuts.
- Loosen the axle nut.
- If the chain is too tight, back out the left and right chain adjusting nuts, and kick the wheel forward until the chain is too loose.
- Turn in the left and right chain adjusting nuts evenly until the drive chain has the correct amount of slack. To keep the chain and wheel aligned, the notch on the left chain adjuster should align with the same swing arm mark that the right chain adjuster notch aligns with.

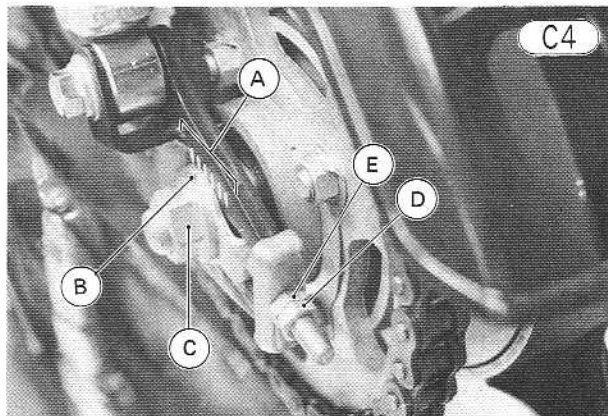

A. Marks C. Axle Nut E. Adjusting Nut
B. Notch D. Locknut

- Tighten both chain adjuster locknuts.
- Tighten the axle nut to 9.0 kg-m (65 ft-lbs) of torque.
- Rotate the wheel, measure the vertical movement again at the tightest position, and readjust if necessary.
- Tighten the rear torque link nut to 3.0 kg-m (22 ft-lbs) of torque.
- Adjust the rear brake.

BRAKES (Disc Type)

Front Brake

Disc and disc pad wear is automatically compensated for and has no effect on the brake lever action. There are no parts that require adjustment on the front brake. However if the brake lever has a soft or "spongy" feeling, check the brake fluid level in the master cylinder and bleed the air from the brake line (Pg. 146).

Rear Brake

Disc and disc pad wear is automatically compensated for and has no effect on brake pedal action. However, the brake pedal may occasionally require adjustment due to wear of the brake pedal pivot, or in the case of disassembly. Excessive play must be taken up to keep the braking action lag time to a minimum, but enough play must be left to ensure a full braking stroke.

WARNING Adjust the rear brake pedal play after adjusting the brake pedal position. Incorrect adjustment with insufficient free play can cause brake heating, skidding, or loss of control.

NOTE: Check the brake fluid level in accordance with the Periodic Maintenance Chart (Pg. 10). Before adjusting the brake, be sure that all air is bled from the brake line (Pg. 146).

Brake Pedal Position

- When the brake pedal is in its rest position, it should be 0 ~ 30 mm lower than the top of the footpeg.

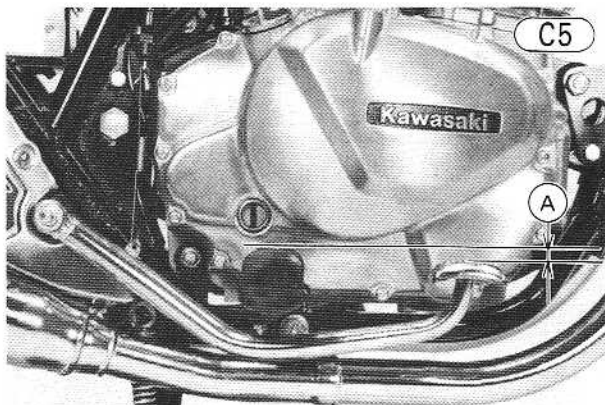

A. 0 ~ 30 mm

- If it is too high; first loosen the brake push rod locknut, slide down the push rod dust cover, and shorten the push rod to give the brake pedal plenty of play. Then adjust the brake pedal position.
- If it is too low; loosen the locknut, turn the brake pedal adjusting bolt to obtain the correct pedal position, and then tighten the locknut.

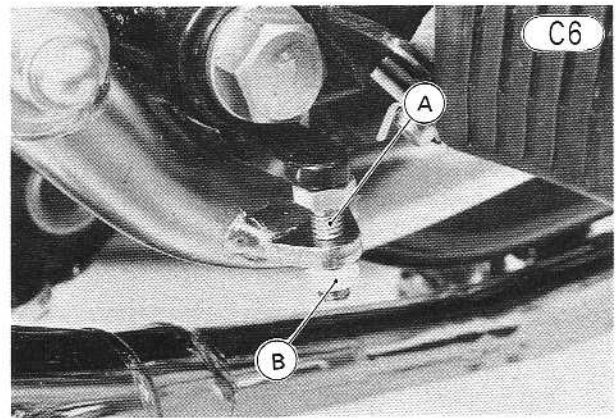

A. Adjusting Bolt B. Locknut

- Adjust the rear brake pedal play.

Rear Brake Pedal Play

- The brake pedal should have 8 ~ 10 mm of free play from the rest position before the push rod contacts the master cylinder piston.

WARNING Lack of free play may cause the brake pads to drag on the disc causing heat build-up, possible brake lock-up and loss of control.

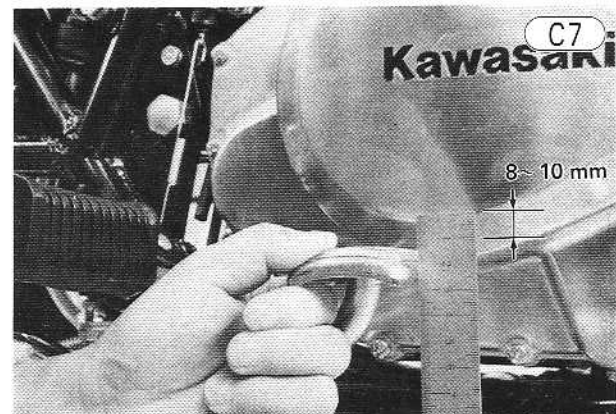

- To adjust play, loosen the push rod locknut and turn the push rod. Tighten the locknut. Feel for restriction of the push rod's side play to identify when the push rod contacts the piston.

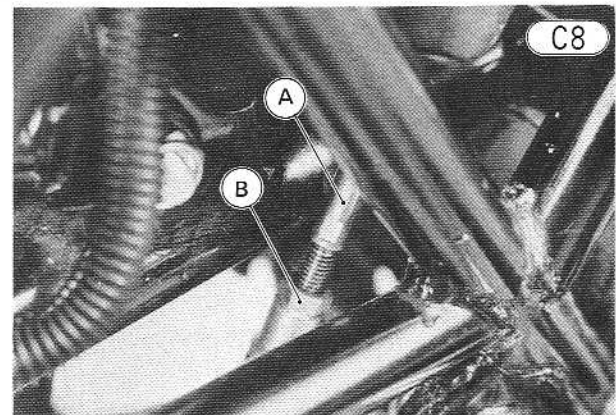

A. Push Rod B. Locknut

- Check the rear brake light switch (Pg. 26).
- Check for brake drag.
- Check braking effectiveness.

26 ADJUSTMENT—CHASSIS

BRAKE LIGHT SWITCH

The front brake light switch, built into the front brake lever holder, is non-adjustable. However, the rear brake light switch, activated by a spring attached to the brake pedal, requires periodic adjustment to compensate for any change in spring shape or tension.

- Check the operation of the switch by turning on the ignition switch and depressing the brake pedal. The brake light should go on after 15 mm of pedal travel.

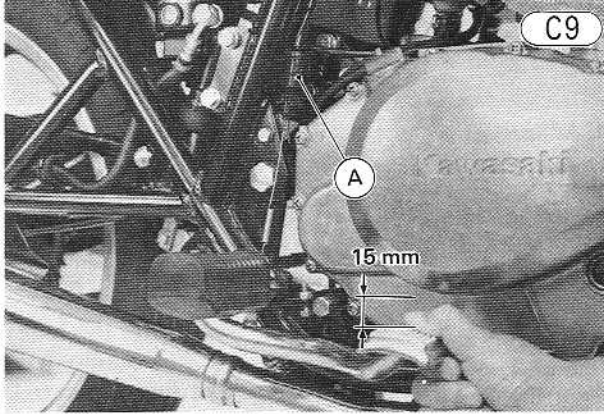

A. Rear Brake Light Switch

- Adjust the switch so that the brake light will go on after the proper amount of brake pedal travel. Raising the switch will make the light go on after less travel; lowering it will require more travel. Adjustment is made by turning the adjusting nut on the switch body.

CAUTION To avoid damaging the electrical connections inside the switch, do not turn the switch body during adjustment.

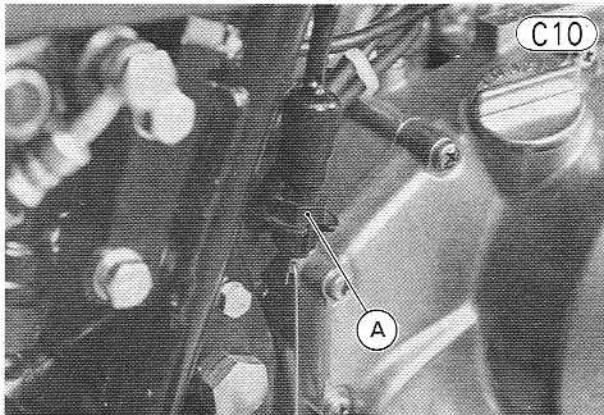

A. Adjusting Nut

STEERING

For safety, the steering should always be kept adjusted so that the handlebar will turn freely but have no play.

If the steering is too tight, it will be difficult to turn the handlebar quickly, the motorcycle may pull to one

side, and the steering stem bearings may become damaged. If the steering is too loose, the handlebar will vibrate and the motorcycle will be unstable and difficult to steer in a straight line.

To check the steering adjustment, first place a stand or block under the engine so that the front wheel is raised off the ground. Push the handlebar lightly to each side; if it continues moving under its own momentum, the steering is not too tight. Squatting in front of the motorcycle, grasp the lower ends of the front fork at the axle, and push and pull the fork end back and forth; if play is felt, the steering is too loose.

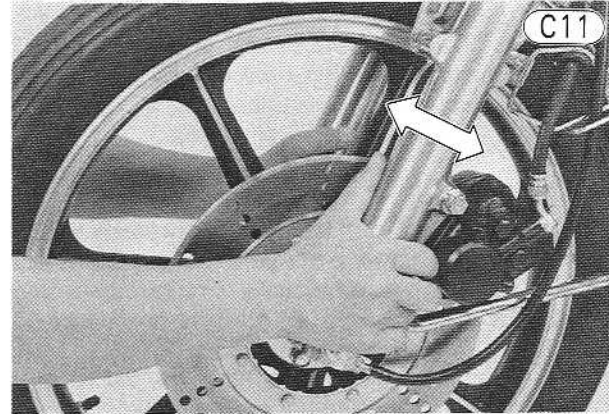

To adjust the steering:

- Put the motorcycle up on its center stand, and jack or prop up the engine so that the front wheel will be off the ground.
- Remove the fuel tank (Pg. 39) to avoid damaging the painted surface.
- Loosen the front fork lower clamp bolts (2) to free the fork tubes from the steering stem during adjustment.

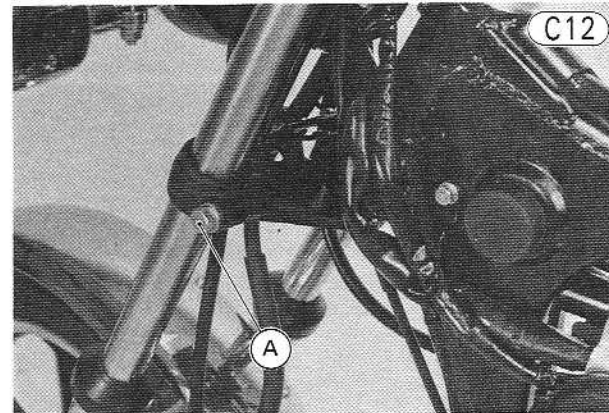

A. Lower Clamp Bolt

- Loosen the steering stem head bolt and head clamp bolt, and back out the steering stem locknut using the stem nut wrench (special tool) 1 or 2 turns until it turns without drag.

NOTE: Do not back out the steering stem locknut more than a couple of turns. If the locknut is backed off too far, the bearing balls in the steering stem may fall out of place. This will necessitate steering stem removal and installation.

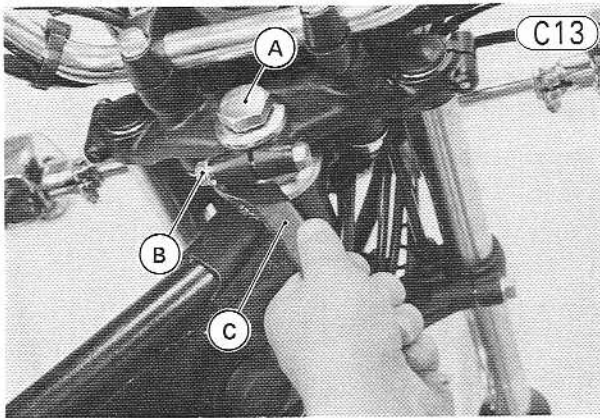

A. Stem Head Bolt
B. Head Clamp Bolt
C. Stem Nut Wrench (57001-134)

- Tighten the stem locknut to 2.0 kg-m (14.5 ft-lbs) of torque.

NOTE: If a suitable torque wrench is not available, tighten the steering stem locknut lightly (until it just becomes hard to turn), and then continue for another 1/16 turn (about 20° travel) from that point.

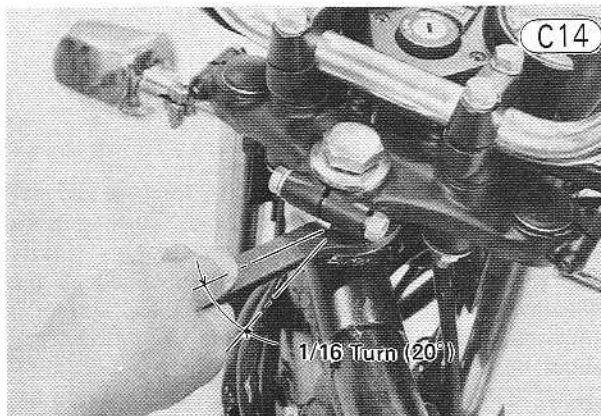

- Tighten the steering stem head bolt to 4.0 kg-m (29 ft-lbs) of torque.
- Tighten the steering stem head clamp bolt to 1.8 kg-m (13.0 ft-lbs) of torque.
- Tighten the front fork lower clamp bolts (2) to 2.5 kg-m (18.0 ft-lbs) of torque.
- Check the steering again. If the steering is too tight or too loose in spite of correct adjustment, inspect the steering stem parts according to the maintenance section (Pg. 150).
- Remount the fuel tank (Pg. 39).

WHEEL BALANCE (Cast Wheel)

To improve stability and decrease vibration at high speed, the front and rear wheels must be kept balanced.

Check and balance the wheels when required, or when a tire is replaced with a new one:

- Remove the wheel (Pg. 89 or 97).
- Check that the wheel is not damaged.
- Suspend the wheel so that it can be spun freely.
- Spin the wheel lightly, and mark the rim at the top when the wheel stops.

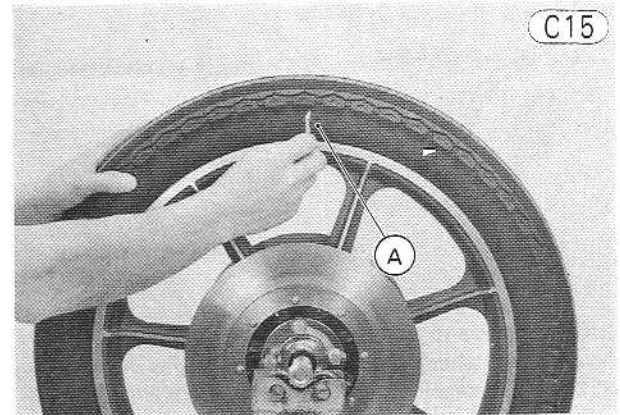

A. Mark

- Repeat this procedure several times. If the wheel stops of its own accord in various positions, it is well balanced.
- However, if the wheel always stops in one position, temporarily attach a balance weight on the rim at the marked spot with tape.
- Rotate the wheel ¼ turn, and see whether or not the wheel stops in this position. If it does, the correct balance weight is being used.

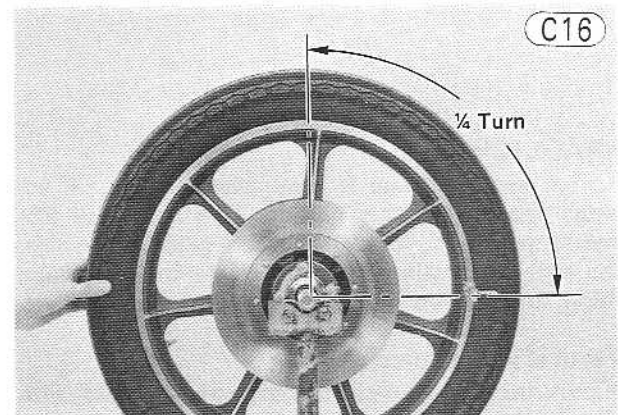

- If the wheel rotates and the weight goes up, replace the weight with the next heavier size. If the wheel rotates and the weight goes down, replace the weight with the next lighter size. Repeat these steps until the wheel remains at rest after being rotated ¼ turn.
- Rotate the wheel another ¼ turn and then another ¼ turn to see if the wheel is correctly balanced.
- Repeat the entire procedures as many times as necessary to achieve correct wheel balance.
- To install the balance weights on the rim, first reduce the tire pressure, pry the tire bead from the rim, and then insert the blade part of the balance weight between the rim and the tire bead until the stepped portions of the weight is hooked over the rim edge.

28 ADJUSTMENT—CHASSIS

Balance Weight Installation

C17

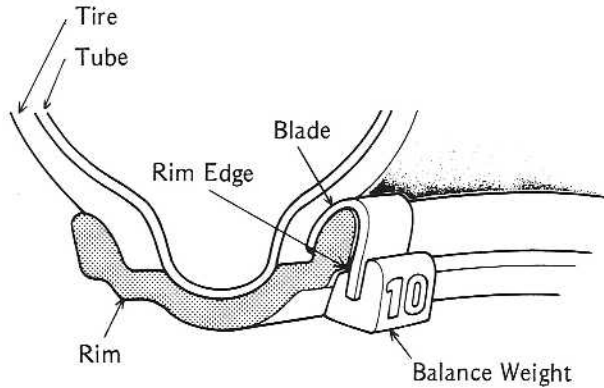

- Inflation the tire to standard pressure (Pg. 140).
 - Mount the wheel on the motorcycle (Pg. 89 or 97).
- NOTES:** 1. Balance weights are available from Kawasaki Dealers in 10, 20, and 30 gram sizes. An imbalance of less than 10 grams will not usually affect running stability.
2. When removing a tire from a rim, mark the valve stem location on the tire so that it can be replaced in the same position.
 3. When installing a new tire, be sure to go through the balancing procedure.
 4. If a new tire is installed, the yellow paint mark on the tire should be aligned with the valve stem for best balancing results.

HEADLIGHT

The headlight beam is adjustable vertically. If adjusted too low, neither low nor high beam will illuminate the road far enough ahead. If adjusted too high, the high beam will fail to illuminate the road close ahead, and the low beam will dazzle oncoming driver.

Vertical Adjustment

- Check that the headlight is aimed straight ahead, with the brightest spot slightly below horizontal on high beam.

Vertical Adjustment

C18

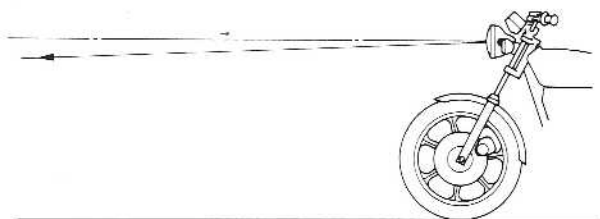

- If adjustment is necessary, loosen the mounting bolt on each side of the headlight housing, and move the headlight up or down until the vertical aim is correct. Tighten the mounting bolts.

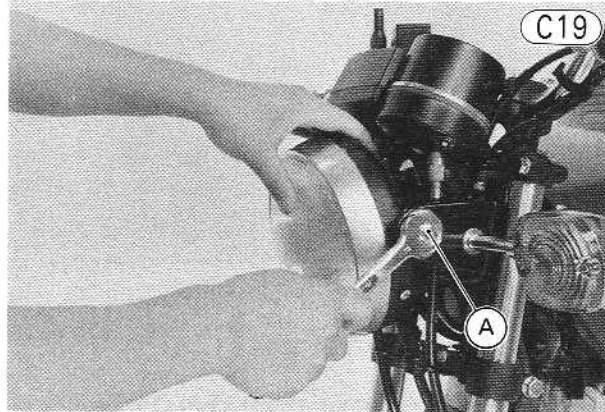

A. Mounting Bolt

NOTE: Check the local regulations that apply to motorcycle operation.

HORN

The horn contacts wear down after long use and may need to be adjusted from time to time. Turning in the adjusting screw compensates for contact wear. If satisfactory horn performance cannot be obtained by this adjustment when the rest of the electrical system is functioning properly, the horn must be replaced. It cannot be disassembled.

WARNING To avoid serious burn, never touch a hot engine or exhaust pipe during horn adjustment.

CAUTION Do not turn the adjusting screw in too far, since doing so will increase horn current with the possibility of burning out the horn coil.

- Disconnect the black horn lead; and connect an ammeter in series to the horn circuit. The + ammeter lead goes to the horn terminal and the - ammeter lead to the black lead.

Horn Current Measurement

C20

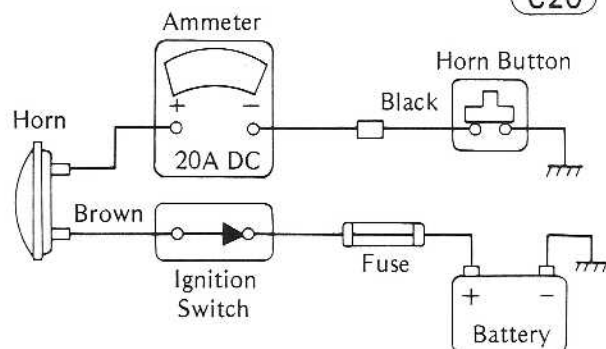

- Turn on the ignition switch, and keep the horn button pressed while turning the horn adjusting screw. Adjust for the best horn sound while keeping the current between 1.8 ~ 2.3 amperes.

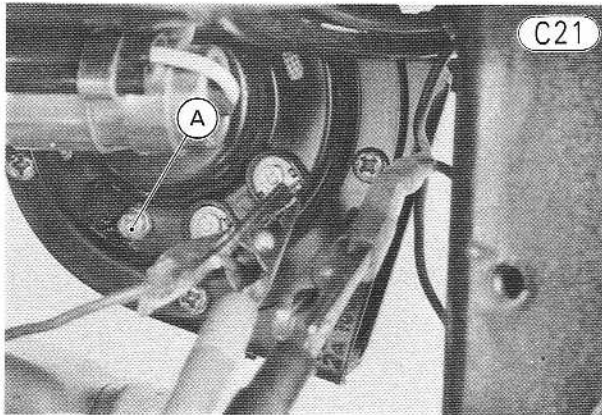

A. Adjusting Screw

- Tighten the adjusting screw locknut.
- NOTE:** The horn will not sound properly if it is mounted incorrectly or if any cable or other part is touching it.

LUBRICATION

Lubricate the exposed parts which are subject to rust, with either motor oil or regular grease whenever the vehicle has been operated under wet or rainy conditions, and especially after using a high-pressure spray washer. Before lubricating each part, clean off any rusty spots with rust remover and wipe off any grease, oil, dirt, or grime.

Clutch and Brake Levers

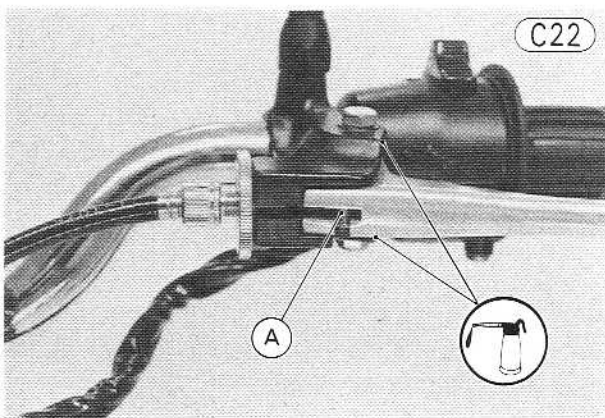

A. Grease

Clutch and Throttle Cables

Lubricate the clutch cable and throttle cables as shown.

Cable Lubrication

C23

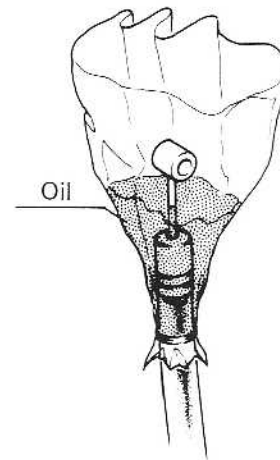

Throttle Grip

Apply grease to the handlebar where the throttle grip turns. Apply a light coat of grease to the exposed portion of the throttle inner cables and their catches in the throttle grip.

Fit the throttle cables into the throttle grip.

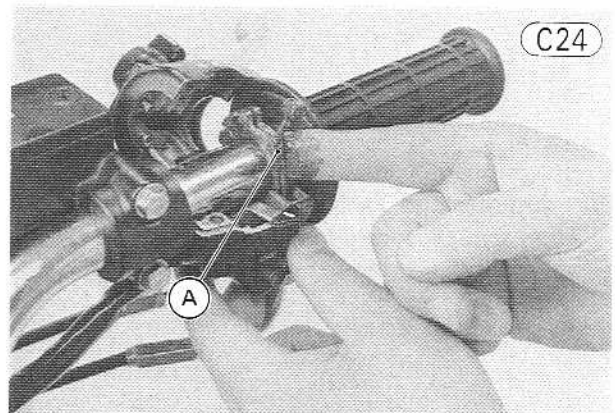

A. Grease

Left Footpeg, Side Stand

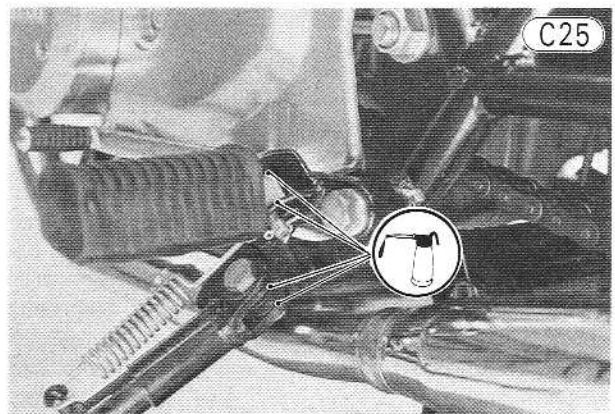

C25

30 ADJUSTMENT—CHASSIS

Swing Arm Pivot

Force grease into the grease nipple until it comes out from both sides of the swing arm. Wipe off any excess grease.

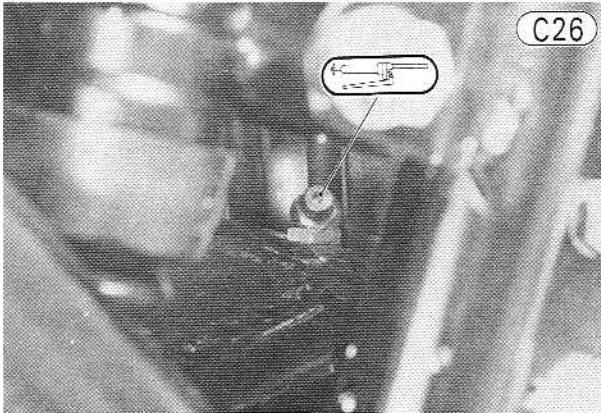

Right Footpeg, Brake Pedal

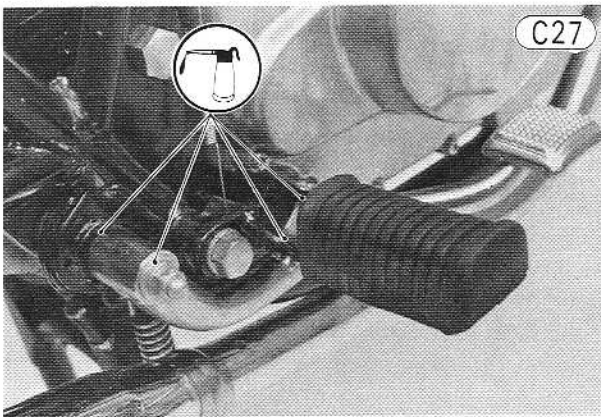

Speedometer and Tachometer Cables

Apply grease sparingly to the inner cables.

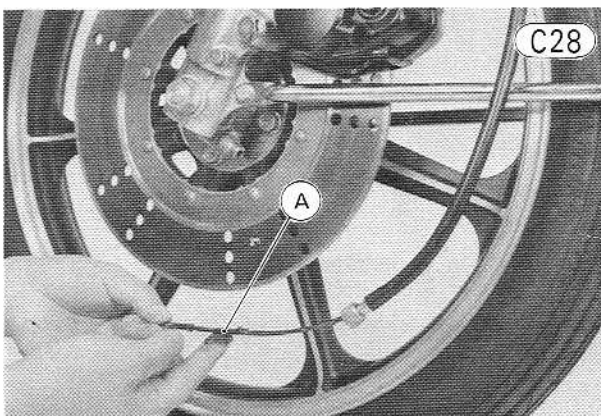

A. Grease

Others

Lubricate the drive chain, wheel bearings, speedometer gear housing, and steering stem bearings as explained in the Maintenance Section.

NOTE: A few drops of oil are effective to keep bolts and nuts from rusting and sticking. This makes removal easier. Badly rusted nuts, bolts, etc. should be replaced with new ones.

Disassembly—Introduction

Table of Contents

| | |
|-----------------------------------|----|
| INTRODUCTION TO DISASSEMBLY | 32 |
| TORQUE AND LOCKING AGENT | 33 |



32 DISASSEMBLY—INTRODUCTION

INTRODUCTION TO DISASSEMBLY

Detail has not been spared in this section in order that the motorcycle cannot only be taken apart but also put back together properly as well. Photographs, diagrams, notes, cautions, warnings, and detailed descriptions have been included wherever necessary. Nevertheless, even a detailed account has limitations; a certain amount of basic knowledge is also required for successful work.

Especially note the following:

(1) Edges

Watch for sharp edges, especially during major engine disassembly and assembly. Protect your hands with gloves or a piece of thick cloth when lifting the engine or turning it over.

(2) Dirt

Before removal and disassembly, clean the motorcycle. Any dirt entering the engine, carburetor or other parts will work as an abrasive and shorten the life of the motorcycle. For the same reason, before installing a new part, clean off any dust or metal fillings.

(3) Tightening Sequence

Where there is a tightening sequence indication in this Service Manual; the bolts, nuts, or screws must be tightened in the order and method indicated. When installing a part with several bolts, nuts, or screws; they should all be started in their holes and tightened to a snug fit. Then tighten them evenly, according to the tightening sequence, to the specified torque. This is to avoid distortion of the part and/or causing gas or oil leakage. Conversely when loosening the bolts, nuts, or screws; loosen all of them about a quarter of turn and then remove them.

(4) Torque

The torque values given in this Service Manual should always be adhered to. Either too little or too much torque may lead to serious damage. Use a good quality, reliable torque wrench.

(5) Force

Common sense should dictate how much force is necessary in assembly and disassembly. If a part seems especially difficult to remove or install, stop and examine what may be causing the problem. Whenever tapping is necessary, tap lightly using a wooden or plastic-faced mallet. Use an impact driver for screws (particularly for the removal of screws held by a locking agent) in order to avoid damaging the screw heads.

(6) Lubricant

Don't use just any oil or grease. Some oils and greases in particular should be used only in certain applications and may be harmful if used in an application for which they are not intended.

(7) Battery Ground

Before performing any disassembly operations on the motorcycle, remove the ground (—) lead from the battery to prevent the possibility of accidentally turning the engine over while partially disassembled.

(8) Engine Rotation

When turning the crankshaft by hand, always turn it in the direction of normal rotation; which is counterclockwise, viewed from the left side of the engine. This will ensure proper adjustments.

(9) Lubrication

Engine wear is generally at its maximum while the engine is warming up and before all the rubbing surfaces have an adequate lubricative film. During assembly, oil or grease (whichever is more suitable) should be applied to any rubbing surface which has lost its lubricative film. Old grease and dirty oil should be cleaned off. Deteriorated grease has lost its lubricative quality and may contain abrasive foreign particles.

(10) Press

A part installed using a press or driver, such as a wheel bearing, should first be coated with oil on its outer or inner circumference so that it will go into place smoothly.

(11) Oil Seal, Grease Seal

Replace any oil or grease seals that have been removed with new ones, as removal generally damages the seals. A seal guide is required for certain oil and grease seals during installation to avoid damage to the seal lips. Before a shaft passes through a seal, apply a little oil, preferably high temperature grease on the lips to reduce rubber to metal friction.

(12) Gasket, O Ring

When in doubt as to the condition of a gasket or O ring, replace it with a new one. The mating surfaces around the gasket should be free of foreign matter and perfectly smooth to avoid oil or compression leaks.

(13) Liquid Gasket, Non-permanent Locking Agent

Follow manufacturer's directions for cleaning and preparing surfaces where these compounds will be used. Apply sparingly. Excessive amounts may block engine oil passages and cause serious damage. An example of a non-permanent locking agent commonly available in North America is Loctite Lock'n Seal (Blue).

(14) Ball Bearing, Oil Seal, Grease Seal Installation

When installing a ball bearing, the bearing race which is affected by friction should be pushed by a suitable driver. This prevents severe stress on the balls and races, and prevents races and balls from being dented. Press a ball bearing until it stops at the stop in the hole or on the shaft. Seals should be pressed into place using a suitable driver, which contacts evenly with the side of the seal until the face of the seal is even with the end of the hole.

(15) Circlip, Retaining Ring

Replace any circlips and retaining rings that were removed with new ones, as removal weakens and deforms them. When installing circlips and retaining rings, take care to compress or expand them only enough to install them and no more.

(16) High Flash-point Solvent

A high flash point solvent is recommended to reduce fire danger. A commercial solvent commonly available in North America is Stoddard solvent (generic name). Always follow manufacturer and container directions regarding the use of any solvent.

(17) Molybdenum Disulfide (MoS₂) Grease

This manual makes reference to molybdenum disulfide grease in the assembly of certain engine and chassis parts. Always check manufacturer recommendations before using such special lubricants.

(18) Electrical Leads

All the electrical leads are either single-color or two-color and, with only a few exceptions, must be connected to leads of the same color. On any of the two-color leads there is a greater amount of one color and a lesser amount of a second color, so a two-color lead is identified by first the primary color and then the secondary color. For example, a yellow wire with thin red stripes is referred to as a "yellow/red" wire; it would be a "red/yellow" wire if the colors were reversed to make red the main color.

TORQUE AND LOCKING AGENT

Tighten all bolts and nuts to the proper torque using an accurate torque wrench. If insufficiently tightened, a bolt or nut may become damaged or fall off, possibly resulting in damage to the motorcycle and injury to the rider. A bolt or nut which is overtightened may become damaged, strip an internal thread, or break and then fall out. The following table lists the tightening torque for the major bolts and nuts, and the parts requiring use of a non-permanent locking agent.

Parts marked with a cross (†) must be retorqued according to the Periodic Maintenance Chart (Pg. 10). One at a time, loosen each bolt or nut ½ turn, then tighten it to the specified torque. Follow the sequence if specified. For engine fasteners, retorque them when the engine is cold (at room temperature).

| Engine Part | Locking Agent (●), Required | Quantity | Metric (kg-m) | English (ft-lbs) | See Pg. |
|---|-----------------------------|----------|---------------|------------------|---------|
| Camshaft chain tensioner cap ϕ 14 P1.5 | — | 1 | 1.5 | 11.0 | 16 |
| Camshaft chain tensioner locknut ϕ 14 P1.5 | — | 1 | 1.5 | 11.0 | 16 |
| Camshaft sprocket bolts ϕ 6 P1.0 | ● | 2 | 1.5 | 11.0 | 48,82 |
| Clutch hub nut ϕ 20 P1.5 | — | 1 | 12.0 | 87 | 64,79 |
| Clutch spring bolts ϕ 6 P1.0 | — | 5 | 1.0 | 87 in-lbs | 64,79 |

| Frame Part | Locking Agent (●), Liquid Gasket (★), Required | Quantity | Metric (kg-m) | English (ft-lbs) | See Pg. |
|--|--|----------|---------------|------------------|------------|
| † Brake pedal pivot cap nut ϕ 8 P1.25 | — | 1 | 2.0 | 14.5 | — |
| † Disc brake parts | See Table G1 on Pg. 92. | | | | |
| † Front fender mounting bolts ϕ 8 P1.25 | — | 4 | — | — | — |
| † Front axle nut ϕ 14 P1.5 | — | 1 | 6.0 | 43 | 89 |
| Front fork bottom Allen bolts ϕ 10 P1.0 | ●,★ | 2 | 1.8 | 13.0 | 112 |
| † Front fork clamp bolts upper ϕ 8 P1.25 | — | 2 | 1.8 | 13.0 | 108,110 |
| lower ϕ 10 P1.25 | — | 2 | 2.5 | 18.0 | 27,108,110 |
| † Handlebar clamp bolts ϕ 8 P1.25 | — | 4 | 1.8 | 13.0 | 105 |
| † Clutch lever pivot bolt ϕ 6 P1.0 | — | 1 | — | — | — |
| † Front brake lever pivot bolt ϕ 6 P1.0 | — | 1 | — | — | — |
| Pad mounting screw ϕ 6 P1.0 | ● | 1 | — | — | — |
| Rear axle nut ϕ 16 P1.5 | — | 1 | 9.0 | 65 | 25 |
| † Rear shock absorber mounting upper cap nuts ϕ 10 P1.25 | — | 2 | 3.0 | 22 | — |
| lower bolts ϕ 10 P1.25 | — | 2 | 3.0 | 22 | — |
| Rear sprocket nuts ϕ 10 P1.25 | — | 4 | 3.0 | 22 | 99 |
| † Side stand bolt ϕ 10 P1.25 | — | 1 | — | — | — |
| † Footpeg mounting bolts ϕ 12 P1.25 | — | 2 | — | — | — |
| † Steering stem head bolt ϕ 16 P1.5 | — | 1 | 4.0 | 29 | 27,108 |
| † Steering stem head clamp bolt ϕ 8 P1.25 | — | 1 | 1.8 | 13.0 | 27 |
| † Steering stem locknut ϕ 30 P1.0 | — | 1 | 2.0 | 14.5 | 27,108 |
| † Swing arm pivot shaft nut ϕ 14 P1.5 | — | 1 | 8.0 | 58 | — |
| † Torque link nuts ϕ 10 P1.25 | — | 2 | 3.0 | 22 | 25 |

36 DISASSEMBLY—INTRODUCTION

The table below, relating tightening torque to thread diameter and pitch, lists the basic torque for the bolts and nuts used on Kawasaki Motorcycles. However, the actual torque that is necessary may vary among bolts and nuts with the same thread diameter and pitch. The bolts and nuts listed under Torque and Locking Agent table vary to a greater or lesser extent from what is given in this table. Refer to this table for only the bolts and nuts not included in the Torque and Locking Agent table. All of these values are for use with dry solvent-cleaned threads.

Coarse threads

| dia (mm) | pitch (mm) | kg-m | ft-lbs |
|----------|------------|-----------|-----------|
| 5 | 0.80 | 0.35~0.50 | 2.5~3.5 |
| 6 | 1.00 | 0.6~0.9 | 4.5~6.5 |
| 8 | 1.25 | 1.6~2.2 | 11.5~16.0 |
| 10 | 1.50 | 3.1~4.2 | 22~30 |
| 12 | 1.75 | 5.4~7.5 | 39~54 |
| 14 | 2.00 | 8.3~11.5 | 60~83 |
| 16 | 2.00 | 13~18 | 94~130 |
| 18 | 2.50 | 18~25 | 130~181 |
| 20 | 2.50 | 26~35 | 188~253 |

Fine threads

| dia (mm) | pitch (mm) | kg-m | ft-lbs |
|----------|------------|-----------|-----------|
| 5 | 0.50 | 0.35~0.50 | 2.5~3.5 |
| 6 | 0.75 | 0.6~0.8 | 4.5~5.5 |
| 8 | 1.00 | 1.4~1.9 | 10.0~13.5 |
| 10 | 1.25 | 2.6~3.5 | 19.0~25 |
| 12 | 1.50 | 4.5~6.2 | 33~45 |
| 14 | 1.50 | 7.4~10.2 | 54~74 |
| 16 | 1.50 | 11.5~16 | 83~116 |
| 18 | 1.50 | 17~23 | 123~166 |
| 20 | 1.50 | 23~33 | 166~239 |

Disassembly—Engine Installed

Table of Contents

| | |
|---------------------------------------|----|
| FLOW CHART..... | 38 |
| FUEL TANK | 39 |
| CARBURETORS | 39 |
| MUFFLERS | 44 |
| TOP END | |
| CYLINDER HEAD COVER, ROCKER ARM | 44 |
| CAMSHAFT | 47 |
| CYLINDER HEAD..... | 48 |
| VALVE, VALVE GUIDE..... | 50 |
| CYLINDER BLOCK..... | 52 |
| PISTONS, PISTON RINGS | 53 |
| LEFT SIDE | |
| ENGINE SPROCKET COVER..... | 54 |
| CLUTCH RELEASE..... | 55 |
| ENGINE SPROCKET..... | 55 |
| STATOR..... | 56 |
| STARTER MOTOR CLUTCH..... | 56 |
| STARTER MOTOR | 58 |
| CONTACT BREAKER..... | 60 |
| TIMING ADVANCER | 61 |
| RIGHT SIDE | |
| RIGHT ENGINE COVER | 62 |
| CLUTCH..... | 62 |
| OIL PUMP | 64 |
| EXTERNAL SHIFT MECHANISM | 65 |

FLOW CHART
Disassembly - Engine Installed

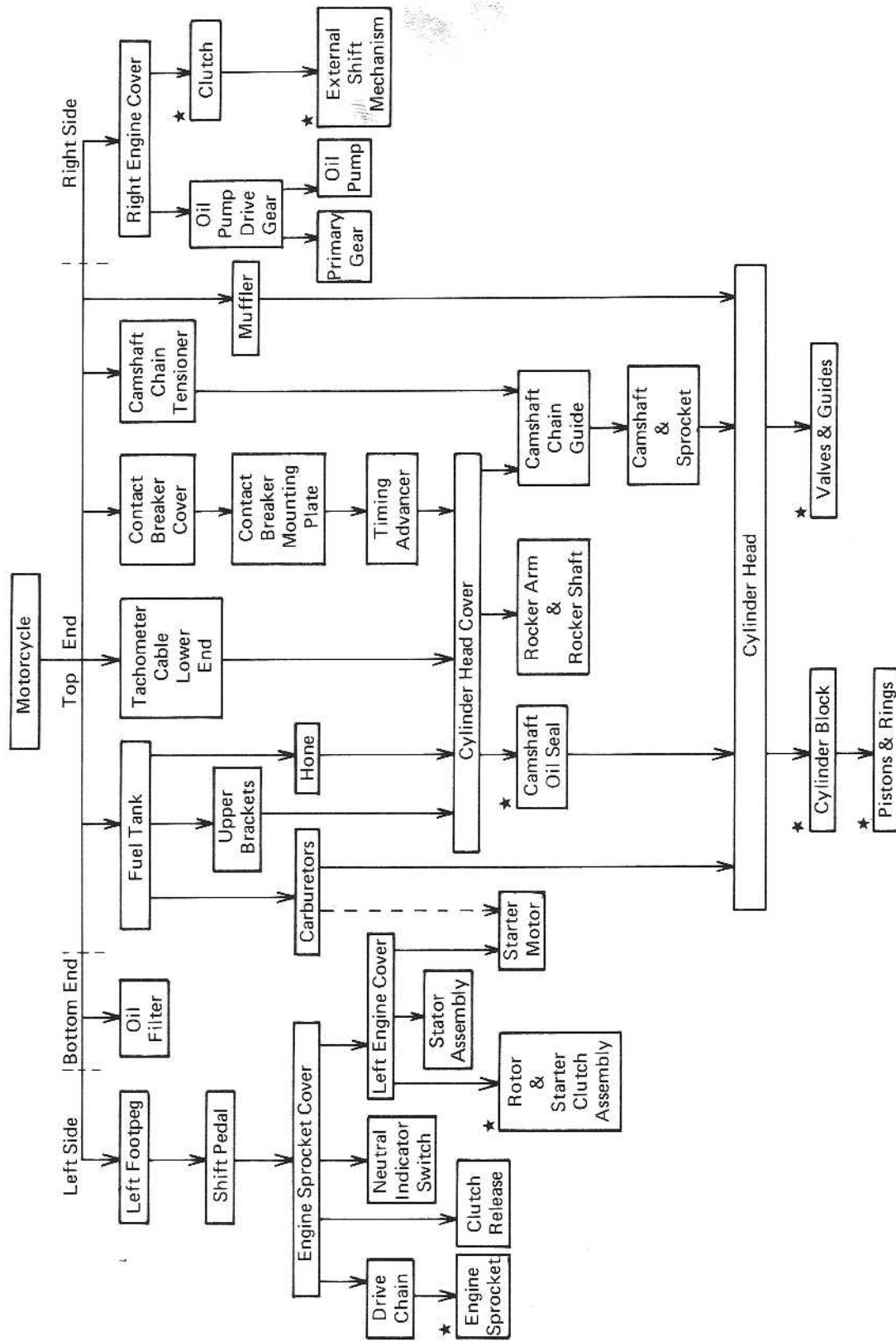

This chart is intended to be aids to proper removal. Select the component you wish to remove and follow the arrows to that point on the chart. Action with a mark * requires special tool for removal, installation, disassembly or assembly.

FUEL TANK**Removal:**

- Unlock the seat and swing it open.
- Turn the fuel tap to the "OFF" position, slide the hose clamp down, and pull the fuel hose off the tap.
- Unhook the rubber retainer on the rear of the fuel tank by pulling both tabs outward.

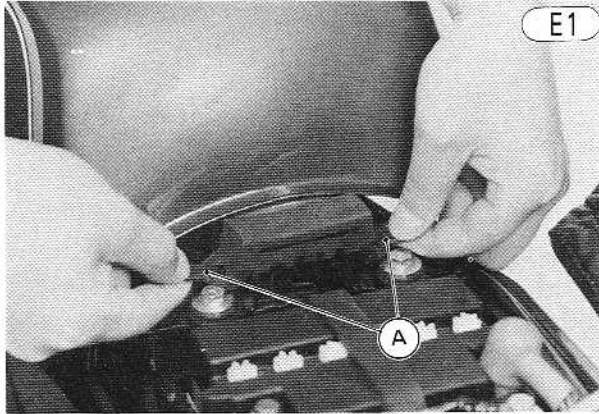
**A. Rubber Retainer Tab**

- Lift up the rear end of the fuel tank, and pull the fuel tank off toward the rear.

Installation:

- Make sure that the rubber dampers are in place, and install the rubber retainer.
- Mount the fuel tank and hook the rubber retainer onto the hook pins.
- Fit the fuel hose back onto the fuel tap, and slide the clamp back into place.
- Push the seat back down.

CARBURETORS**Removal:**

- Remove the fuel tank (Pg. 39).
- Pull out the overflow and breather tubes from between the rear of the engine and the swing arm.
- Loosen the carburetor holder clamp and the air cleaner duct clamp for each carburetor, and slip them out of place.

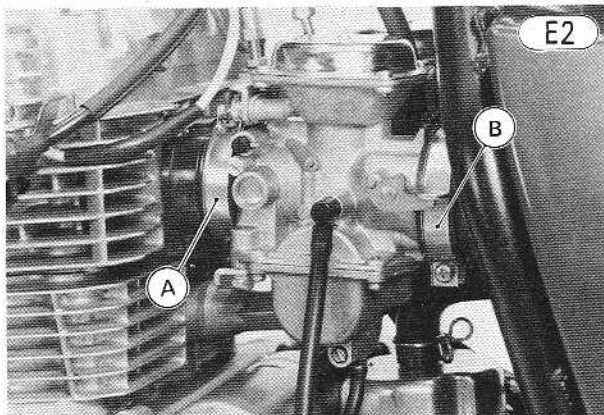

A. Carburetor Holder Clamp
B. Air Cleaner Duct Clamp

- Pull the carburetors off to the rear and out. Be sure not to damage the throttle cables.
- Turn in fully the locknuts and adjusting nuts at the upper end of the throttle cables so as to give the cables plenty of play.

CAUTION Removing the throttle cables from the carburetors without enough cable play, may cause throttle cable damage.

- Loosen the locknuts and turn out the cable adjusters on the lower ends of the throttle cables all the way, to remove them from the adjuster brackets.

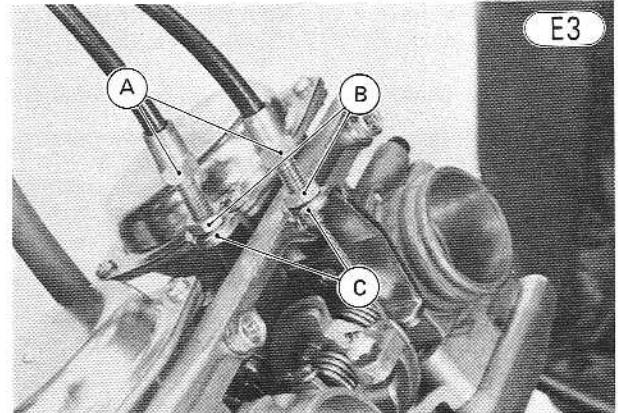

A. Adjusters B. Locknuts C. Adjuster Bracket

- Disconnect the cable nipples from the pulley.

Installation:

- Fit the nipple of the decelerator throttle cable into the rear socket in the pulley, and screw the adjuster into its bracket.
- Fit the other cable nipple into the front socket in the pulley, and install the adjuster onto the bracket.

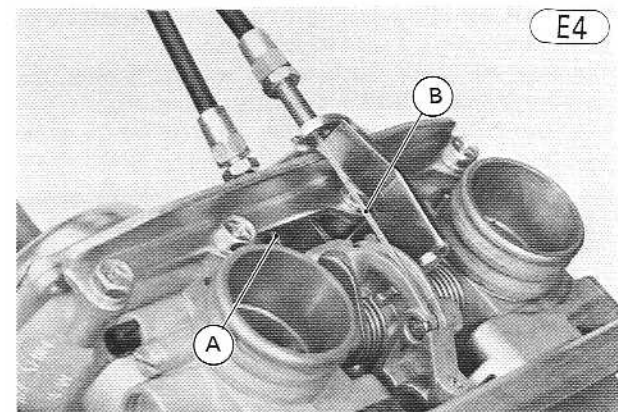

A. Decelerator Throttle Cable
B. Accelerator Throttle Cable

- Center each adjuster in place in the bracket, and tighten the locknuts.
- Make sure that the carburetor holder clamps and air cleaner duct clamps are in place, and that the screw heads are facing outward.
- Slip the carburetors back into place.
- Check that the ducts and holders are all properly fitted on the carburetors, and tighten the clamps.
- Route the carburetor overflow tubes (2) and breather tubes (2) to the rear of the engine.

40 DISASSEMBLY—ENGINE INSTALLED

- Install the fuel tank (Pg. 39).
- Adjust the throttle cables (Pg. 17).
- Adjust the carburetors (Pg. 18).

Carburetor Separation/Link Mechanism

The carburetor parts listed below can be removed without separating the carburetors.

| | |
|--------------------|---------------------|
| Pilot Screw | Vacuum piston |
| Jet Needle | Float |
| Valve Needle | Pilot Jet |
| Primary Main Jet | Main Jet Bleed Pipe |
| Secondary Main Jet | Needle Jet Holder |

- Remove the choke link screw (2) and lockwasher (13).

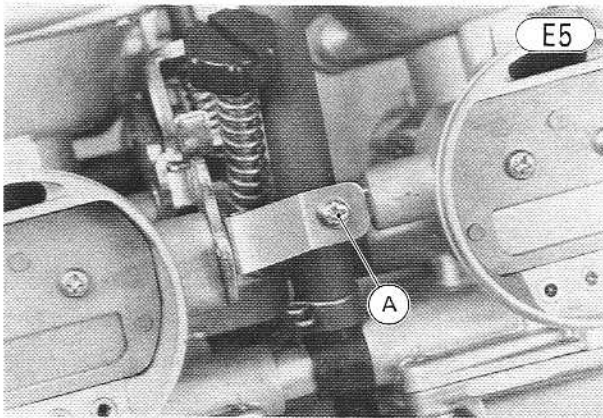

A. Choke Link Screw

- Remove the bolts (8) and lockwashers (8), and take off the upper and lower mounting plates to separate the carburetors. The linkage mechanism spring (10) and fuel hose 3-way joint come off.
- Turn out the idle adjusting screw (9) on the left carburetor and remove it with its spring (15).
- Remove the screw, lockwasher, and flat washer, and remove the cable bracket assembly.
- Remove the nut and lockwasher, and remove the choke link and fast idling cam.

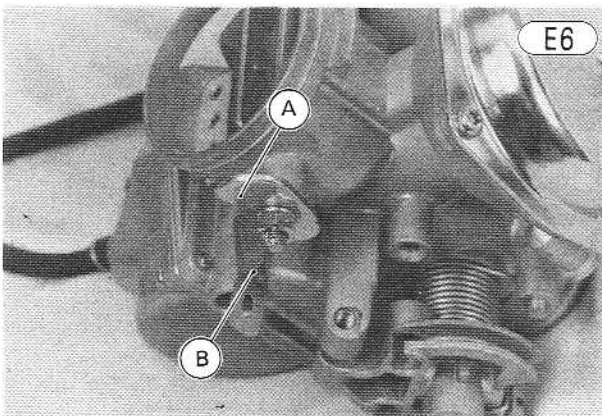

A. Fast Idling Cam B. Choke Link

Installation:

- Install the fast idling cam and choke link in the direction shown in figure E8, when the choke valves are completely closed.

- Install the cable bracket assembly. Apply a non-permanent locking agent to the screw.
- Install the idle adjusting screw with its spring.
- Install the upper and lower mounting plates on one of the carburetors. Note the direction of the plates. Use a non-permanent locking agent on each lower mounting bolt.

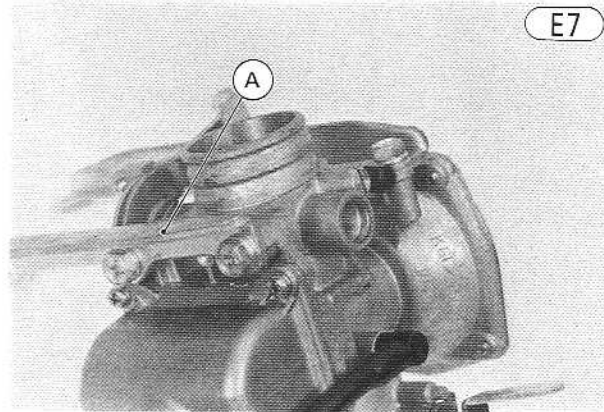

A. Mounting Plate

- Check that the O rings (4) are properly in place, and install the fuel hose 3-way joint with the hose pointing upward. The longer side of the joint goes into the left carburetor.

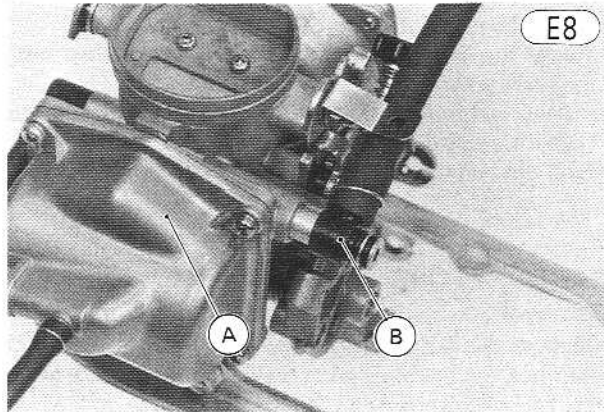

A. Left Carburetor B. 3-way Joint

- Connect both carburetors and hook both ends of the linkage mechanism spring as shown below.

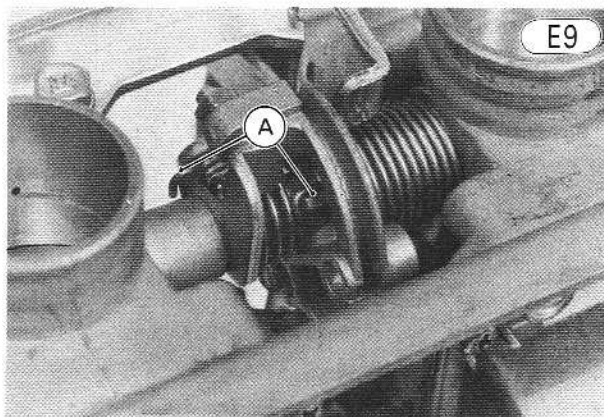

A. Spring Ends

Carburetors

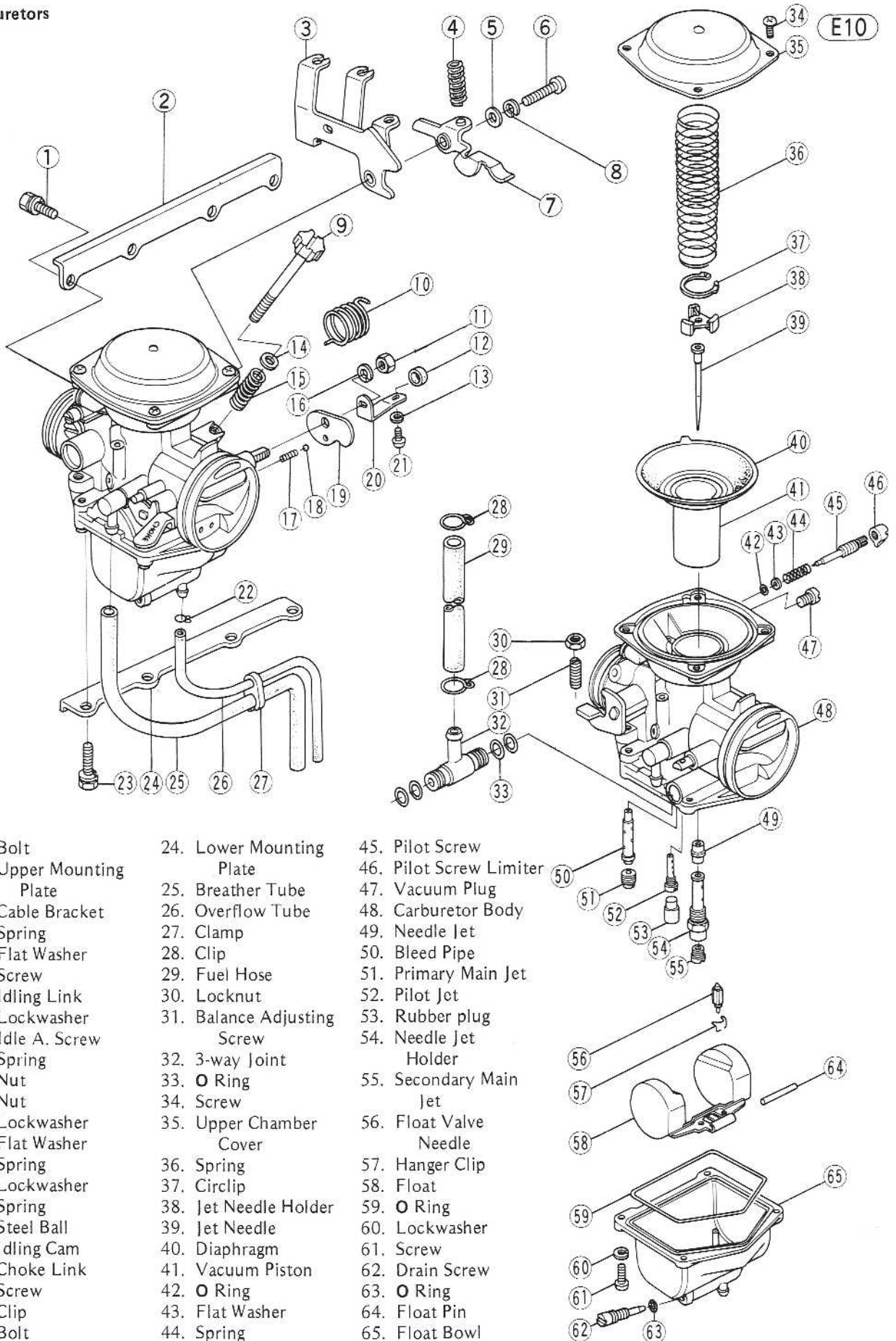

- | | | |
|-------------------------|-----------------------------|-------------------------|
| 1. Bolt | 24. Lower Mounting Plate | 45. Pilot Screw |
| 2. Upper Mounting Plate | 25. Breather Tube | 46. Pilot Screw Limiter |
| 3. Cable Bracket | 26. Overflow Tube | 47. Vacuum Plug |
| 4. Spring | 27. Clamp | 48. Carburetor Body |
| 5. Flat Washer | 28. Clip | 49. Needle Jet |
| 6. Screw | 29. Fuel Hose | 50. Bleed Pipe |
| 7. Idling Link | 30. Locknut | 51. Primary Main Jet |
| 8. Lockwasher | 31. Balance Adjusting Screw | 52. Pilot Jet |
| 9. Idle A. Screw | 32. 3-way Joint | 53. Rubber plug |
| 10. Spring | 33. O Ring | 54. Needle Jet Holder |
| 11. Nut | 34. Screw | 55. Secondary Main Jet |
| 12. Nut | 35. Upper Chamber Cover | |
| 13. Lockwasher | 36. Spring | |
| 14. Flat Washer | 37. Circlip | |
| 15. Spring | 38. Jet Needle Holder | |
| 16. Lockwasher | 39. Jet Needle | |
| 17. Spring | 40. Diaphragm | |
| 18. Steel Ball | 41. Vacuum Piston | |
| 19. Idling Cam | 42. O Ring | |
| 20. Choke Link | 43. Flat Washer | |
| 21. Screw | 44. Spring | |
| 22. Clip | | |
| 23. Bolt | | |

E10

42 DISASSEMBLY—ENGINE INSTALLED

- Install the remaining bolts and lockwashers for the mounting plate. Check the carburetor alignment.
- Install the choke link screw and lockwasher.
- Before installing the carburetors on the motorcycle, perform the "Carburetor Function Checks".

Carburetor Function Checks:

1. Choke Valves

- Operate the choke lever to make sure that both choke valves open and close at the same time.
- If they don't, carefully bend or reposition the choke link. Tighten the nut.

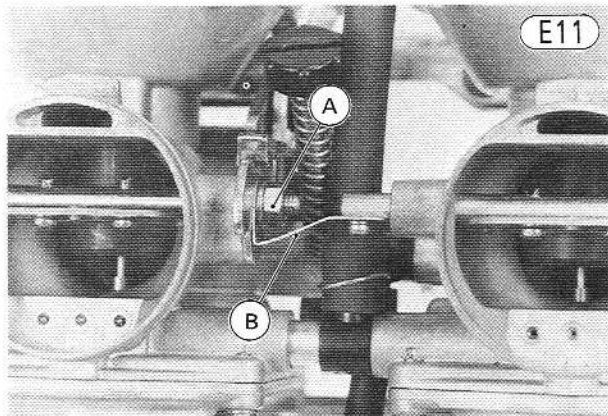

A. Nut B. Choke Link

- Push on each relief valve in the choke valves to see if it returns smoothly. If it does not, the spring behind the relief valve is weak or damaged and the carburetor body must be replaced as an assembly.

CAUTION If the relief valve or choke valve does not work properly, the proper fuel/air mixture for cold idling could be upset.

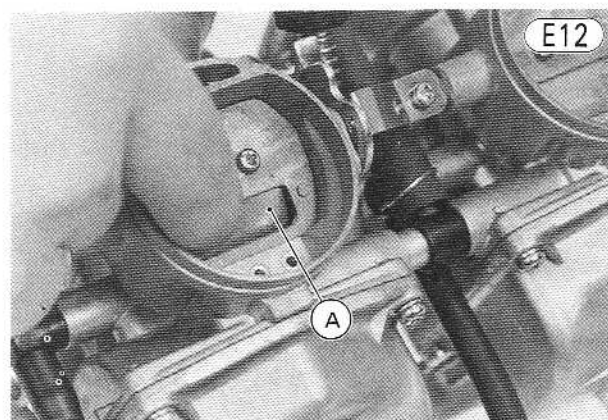

A. Relief Valve

2. Vacuum Pistons

- Check that each vacuum piston slides up and down smoothly.
- If there is any doubt, pull out the vacuum piston and check for any damage.
- Situate the carburetors upright, set the vacuum piston at its topmost position, block the air passage hole to

prevent air from entering through it, and release the piston. The piston should slide down very slowly (It should take more than ten seconds).

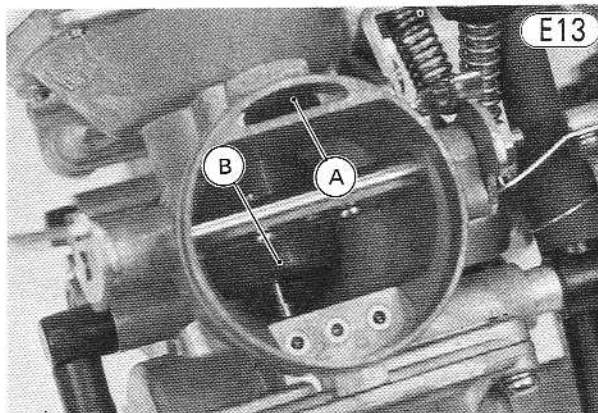

A. Air Passage Hole B. Vacuum Piston

- If it does not, the diaphragm or piston is probably damaged and must be replaced.

CAUTION If the diaphragm or vacuum piston does not work properly, engine malfunction could result.

3. Fast Idling Cam

- Turn out the idle adjusting screw until there is clearance between it and the pulley.
- Open the choke valves fully and push up the idling link until the pulley begins to rotate. At this time, the clearance between the idling link and the fast idling cam should be about 1.0 mm.

CAUTION If the clearance is larger, the cold idle speed will be too low and the engine will stall. If the clearance is smaller, the cold idle speed will be too high.

Fast Idling Cam

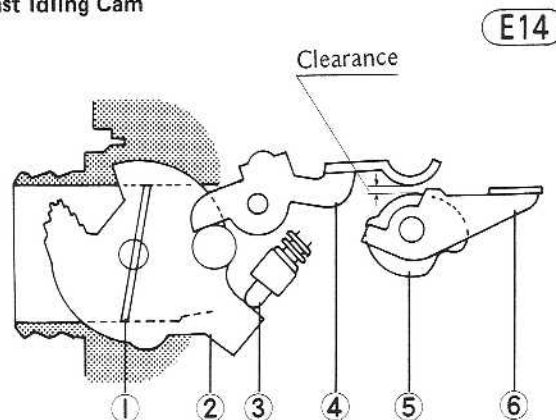

1. Choke Valve 4. Idling Link
2. Pulley 5. Idling Cam
3. Idle Adjusting Screw 6. Choke Lever

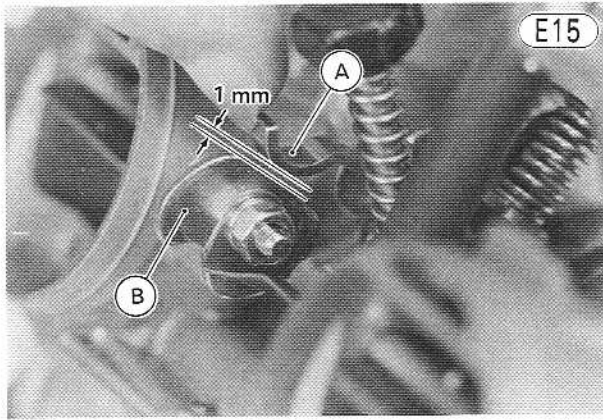

A. Idling Link B. Fast Idling Cam

•If the clearance is incorrect, carefully bend the idling link as required. Recheck the clearance.

4. Butterfly Valves

- Make sure that the butterfly valves open and close smoothly as the pulley is rotated. If they don't check for binding in the carburetor bore or spring damage, and correct as necessary.
- Turn out the idle adjusting screw until there is clearance between it and the pulley. Open the choke valves. Then, check that both butterfly valves close completely and that they begin to open at the same time.

CAUTION If the butterfly valves do not work simultaneously, stable idling or satisfactory carburetor synchronization cannot be achieved.

- If adjustment is necessary, loosen the locknut and turn the adjusting screw on the pulley as required. Tighten the locknut.

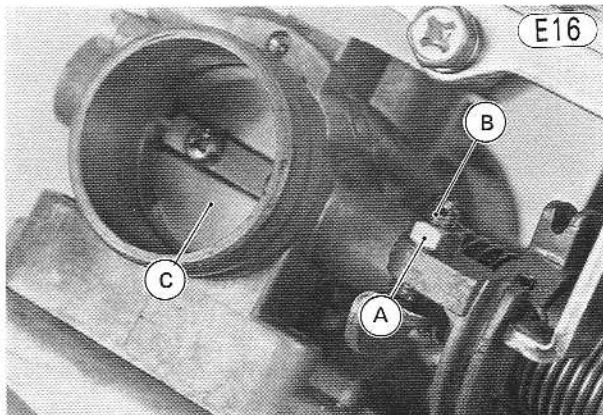

A. Locknut C. Butterfly Valve
B. Adjusting Screw

5. Service Fuel Level

Situate the carburetors so that they are perfectly level, and measure the service fuel level for each carburetor, and adjust it if necessary (Pg. 118).

CAUTION If the service fuel level is incorrect, the proper fuel/air mixture for good engine performance cannot be obtained.

Carburetor Disassembly:

- Remove the screws (4) and the upper chamber cover 35.
- Being careful not to damage the diaphragm, pull out the diaphragm/vacuum piston assembly. Do not use the sharp edge of a tool to separate the diaphragm from the groove.
- Remove the circlip 37 using inside circlip pliers (special tool) and remove the jet needle holder 38 and jet needle 39.
- Remove the pilot screw limiter 46, pilot screw 45, spring 44, flat washer 43, and O ring 42.
- Remove the screws (4) and lockwashers (4), and remove the float bowl 65 and O ring 59.
- Pull out the float pin 64, remove the float 58, and pull out the valve needle 56.
- Remove the primary main jet 51 and the main jet bleed pipe 50.
- Remove the secondary main jet 55 and the jet needle holder 54.
- Pull off the rubber plug 53 and remove the pilot jet 52.

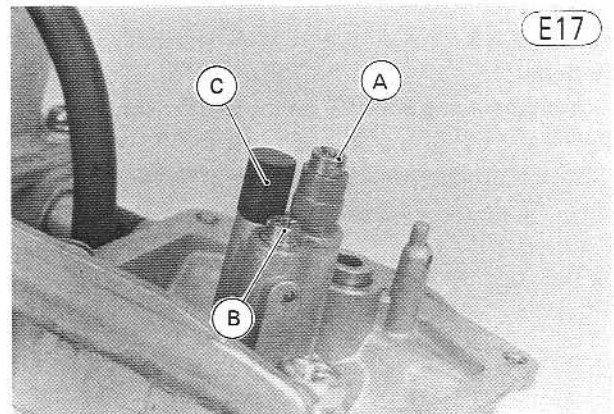

A. Primary Main Jet C. Plug
B. Secondary Main Jet

Assembly Notes:

1. Replace any O rings and rubber plugs if they are damaged or deteriorated.
2. Align the diaphragm tongue with the notch in the upper chamber, and fit the diaphragm sealing lip into its groove.

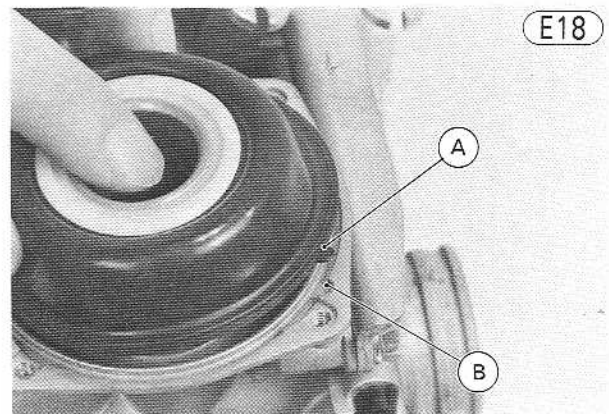

A. Diaphragm Tongue B. Notch

44 DISASSEMBLY—ENGINE INSTALLED

3. Before installing the float, insert the tang on the float plate through the clip on the valve needle. This helps valve needle work properly.

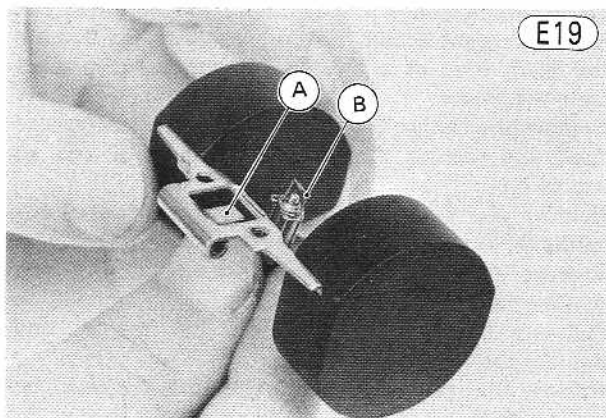

A. Tang B. Clip

MUFFLERS

Removal:

- Loosen the clamp bolts (2) on the muffler connecting pipe.

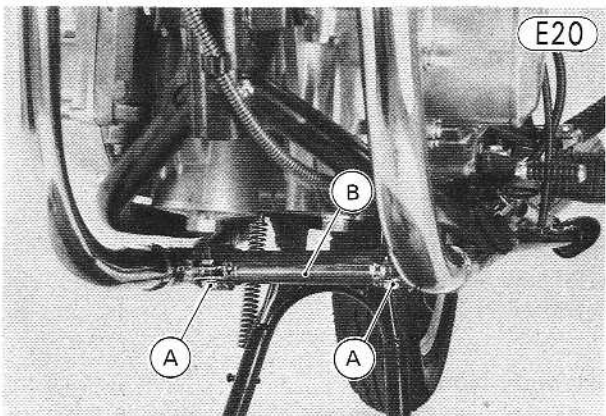

A. Clamp Bolts B. Connecting Pipe

- Remove the exhaust pipe holder nuts and slide both holders off the cylinder head studs. Remove the split keeper.

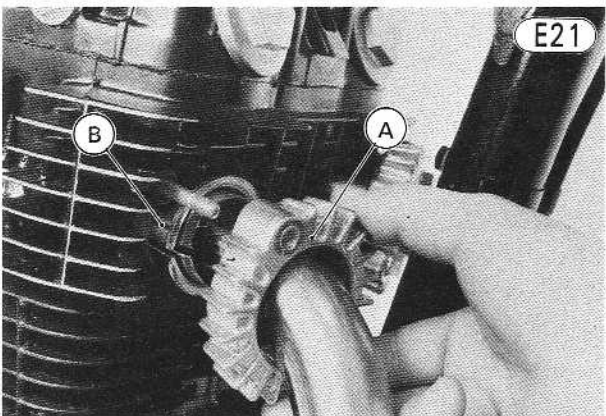

A. Exhaust Pipe Holder B. Split Keeper

- Remove the rear footpeg mounting nuts and flat washers. Pull out the rear footpegs and remove both mufflers together.

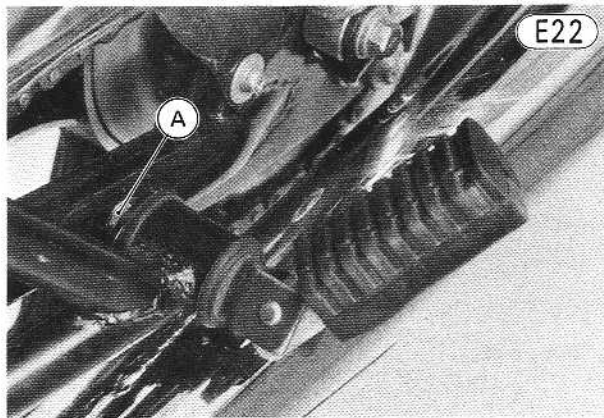

A. Footpeg Mounting Nut

Installation:

- Check the gaskets at the exhaust ports and on both ends of the connecting pipe for damage or deterioration. Replace them if damaged.
- Install the connecting pipe on one of the mufflers. This muffler is installed first.
- Slide each exhaust pipe holder onto the exhaust pipes so that the stepped portion around the inside hole of the holder faces the exhaust port of the engine.

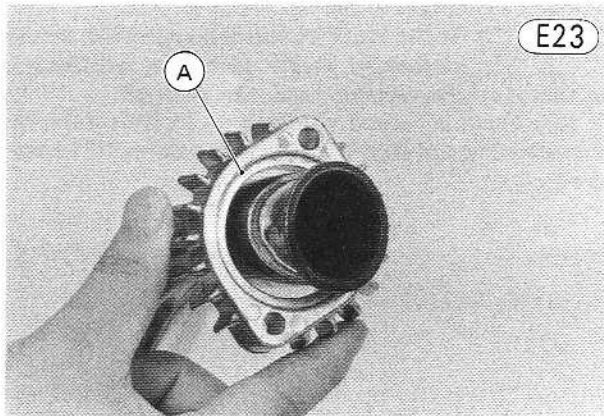

A. Stepped Portion

- Fit the gasket and exhaust pipe into the exhaust port, and loosely fasten the muffler to the frame with a rear footpeg, flat washer, and nut.
- Fit the gasket and the other exhaust pipe into the exhaust port, connect the muffler to the connecting pipe, and install the rear footpeg.
- Fit the split keeper into place with its flange facing outward. Install the exhaust pipe holders tightening the nuts evenly to avoid an exhaust leak.
- Tighten the rear footpeg mounting nuts.
- Tighten the clamp bolts on the connecting pipe.
- Check for exhaust leaks and correct if necessary.

CYLINDER HEAD COVER, ROCKER ARM

Removal:

- Remove the fuel tank (Pg. 39).

- Pull off the spark plug leads and remove the spark plugs.
- Disconnect the leads from the ignition coils and contact breakers.
- Remove the upper bracket bolts (3) and nuts (3), and take off the upper brackets.

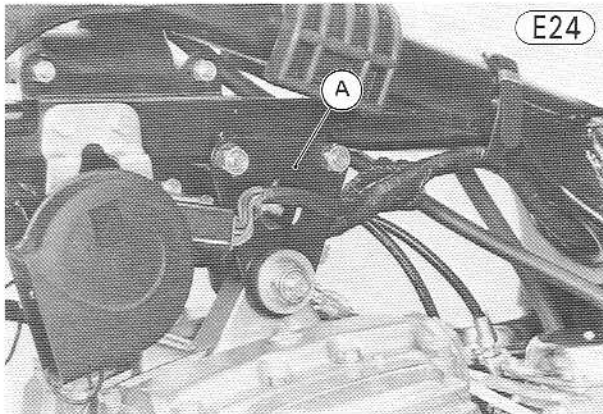

A. Upper Bracket

- Disconnect the horn leads from the horn body. Remove the mounting bolts (2) and lockwashers (2), and remove the horn.
- Disconnect the tachometer cable from the cylinder head cover. Remove the bolt and tachometer pinion holder stop. Pull out the tachometer pinion holder and pinion.

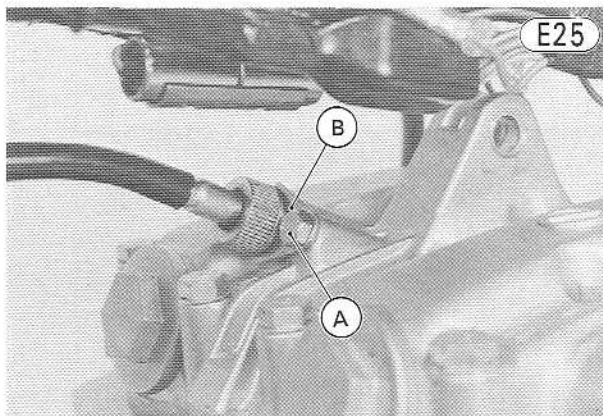

A. Bolt B. Stop

- Remove the valve adjusting caps (4).

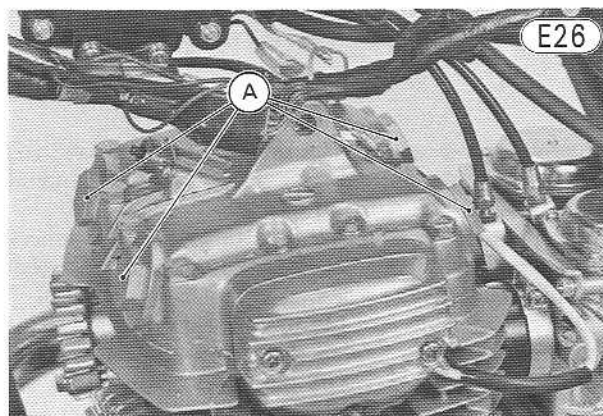

A. Valve Adjusting Caps

- Remove the alternator cover.
- Remove the contact breaker cover and gasket.
- Remove the mounting screws (2) and take off the contact breaker mounting plate.
- Using a 14 mm wrench on the crankshaft to hold the camshaft steady, loosen the bolt on the camshaft. Remove the bolt, flat washer, and timing advancer.

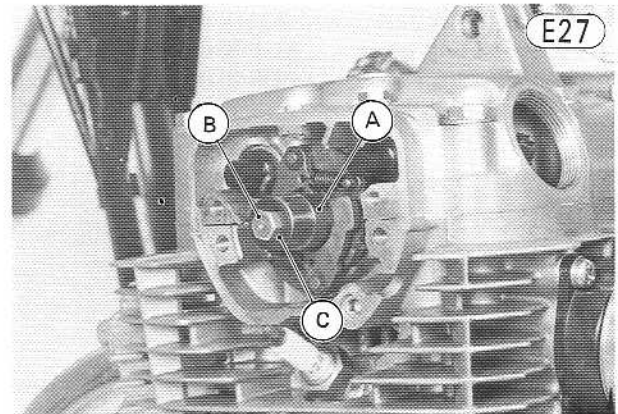

A. Timing Advancer B. Bolt C. Flat Washer

- Remove the 8 mm bolts (8) and 6 mm bolts (6) from the cylinder head cover. Remove the cylinder head cover.
- Pull the oil seal off the camshaft.
- To remove a left rocker arm; pull out the rubber plug and pull out the rocker shaft using a 6 mm bolt.

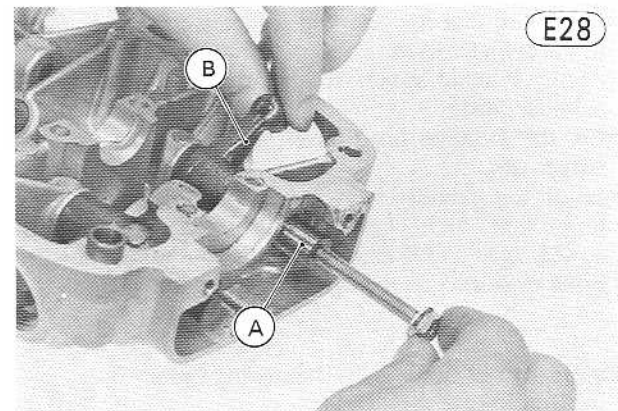

A. Rocker Shaft B. Rocker Arm

- To remove a right rocker arm; remove the bolt and copper washer, pull out the rubber spacer, and pull out the rocker shaft using a 6 mm bolt.

Installation:

- If the rocker shafts are removed from the cylinder head cover, repeat the following two steps.
 - Apply a small amount of molybdenum disulfide grease to the rocker shaft, insert the shaft through the left rocker arm, and fit the rubber plug into the cylinder head cover.
 - Apply a small amount of molybdenum disulfide grease to the rocker shaft, insert the shaft through the right rocker arm, insert the rubber spacer, and install the bolt and copper washer. Tighten the bolt to 4.0 kg-m (29 ft-lbs) of torque.

46 DISASSEMBLY—ENGINE INSTALLED

- With a high flash-point solvent, clean off the mating surfaces of the cylinder head and cylinder head cover. Wipe it dry.
- Make sure that the tachometer pinion is removed from the cylinder head cover.

CAUTION If the cylinder head cover is installed with the tachometer pinion left in the cover, it could cause tachometer gear damage.

- Turn the crankshaft counterclockwise until no cam lobe is pointing upward. At this camshaft position, all the valves are closed, which makes cylinder head cover installation easier.

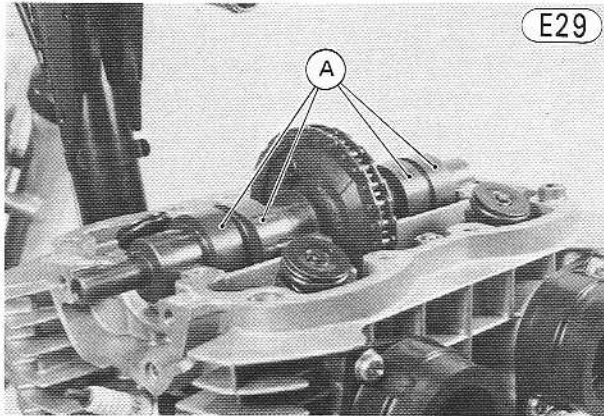

A. Cam Lobes

- Make sure that the two knock pins are properly fitted in the cylinder head.
- Apply a liquid gasket to the mating surface of the cylinder head.
- Fit the cylinder head cover, while holding up each rocker arm.
- Insert the cylinder head cover bolts, and tighten the 6 mm bolts to 1.0 kg-m (87 in-lbs) and the 8 mm bolts to 2.5 kg-m (18.0 ft-lbs). Follow the bolt tightening order embossed on the cylinder head cover.

Cylinder Head Cover Bolts Tightening Order

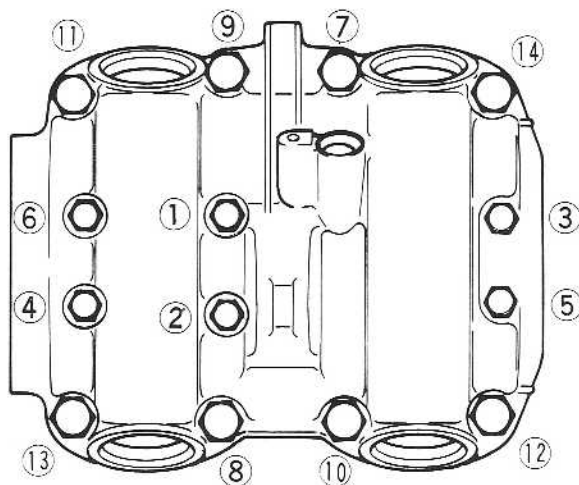

- Adjust the valve clearance (Pg. 16).
- Smear a thin coat of high temperature grease on a new camshaft oil seal, and install it on the camshaft using the oil seal driver (special tool).

CAUTION If the camshaft oil seal is installed prior to the cylinder head cover installation, or if the oil seal is incorrectly installed, it could cause oil leakage or timing advancer binding.

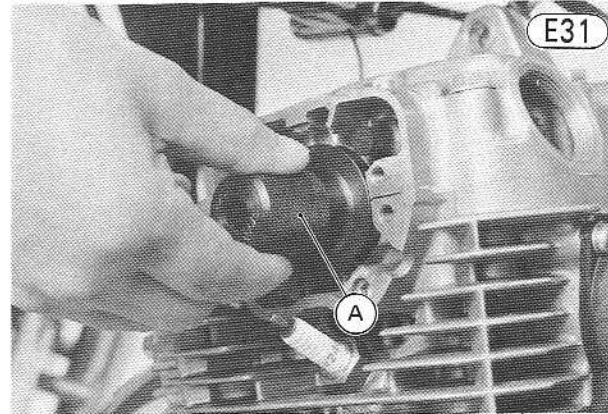

A. Oil Seal Driver (57001-1022)

- Fit the timing advancer onto the camshaft, matching its notch with the pin on the camshaft.

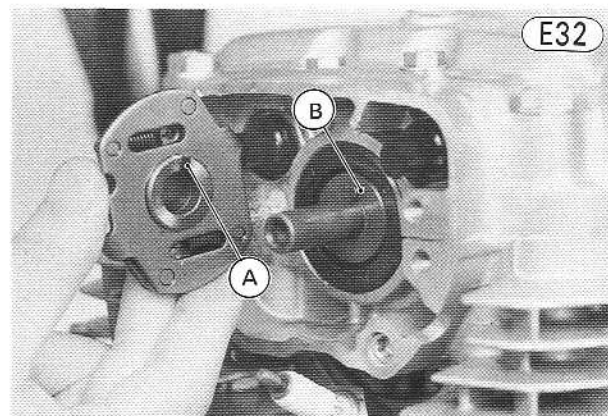

A. Notch

B. Pin

- Apply a non-permanent locking agent to the camshaft bolt. Insert the bolt with its flat washer and tighten it to 0.90 kg-m (78 in-lbs) of torque.
- Install the contact breaker mounting plate, flat washers, and screws. Apply a liquid gasket around the rubber grommet and fit the grommet into place.
- Apply a small amount of molybdenum disulfide grease to the tachometer pinion shaft, and insert it through the pinion holder. Insert the pinion holder into the cylinder head cover, and hold it with the holder stop and bolt.

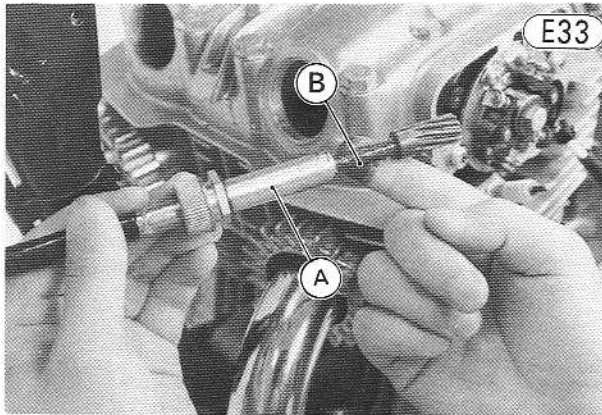

A. Pinion Holder B. Grease here.

- Connect the tachometer cable and tighten the cable nut.
- Install the upper brackets and tighten the 8 mm bolts to 2.4 kg-m (17.5 ft-lbs) and the 10 mm bolt to 4.0 kg-m (29 ft-lbs).
- Install the horn and connect the horn leads.
- Connect the ignition coil leads and contact breaker leads.
- Adjust the ignition timing (Pg. 12).
- Install the valve adjusting caps, contact breaker cover, and alternator cover.
- Insert the spark plugs and tighten them to 2.0 kg-m (14.5 ft-lbs) of torque. Connect the spark plug leads.
- Install the fuel tank (Pg. 39).

CAMSHAFT

Removal:

- Remove the fuel tank (Pg. 39).
- Remove the cylinder head cover (Pg. 44).
- Remove the chain tensioner cap with O ring, loosen the locknut, and remove the chain tensioner assembly from the cylinder block.

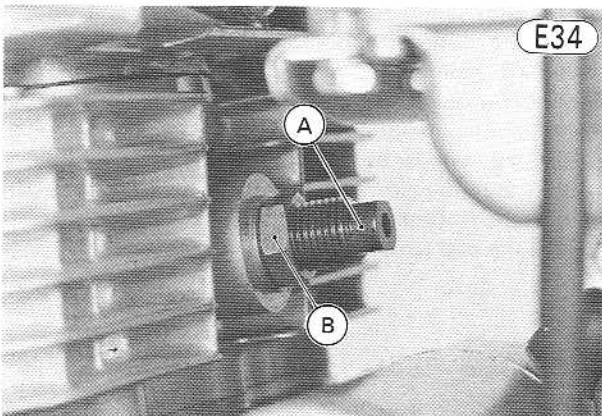

A. Chain Tensioner B. Locknut

- Pull out the camshaft chain guide from the front of the engine.

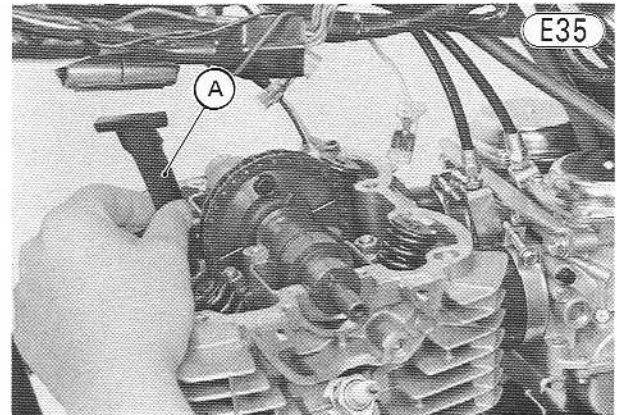

A. Camshaft Chain Guide

- Using a 14 mm wrench on the crankshaft to hold the camshaft steady, remove the camshaft sprocket bolts (2).
 - Slide the sprocket off its position on the camshaft, and slip the chain off the sprocket.
- CAUTION** Always pull the camshaft chain taut while turning the crankshaft when the camshaft chain is loose. This will prevent the lower part of the chain from snagging on the crankshaft.
- Remove the camshaft and camshaft sprocket. Use a screwdriver or wire to keep the chain from falling down into the cylinder block.

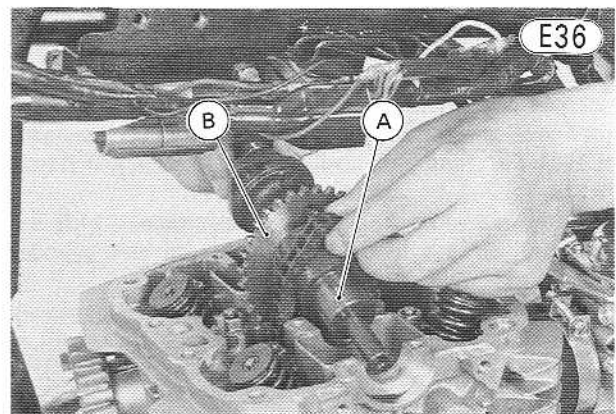

A. Camshaft B. Camshaft Sprocket

Installation:

- Apply engine oil to the cam parts, tachometer gear, and cylinder head journals. If the cylinder head and/or camshaft is replaced with a new one, apply a small amount of molybdenum disulfide grease in place of engine oil.
- Turn the crankshaft counterclockwise until the line (TDC mark) near the mark "1" or "L" on the rotor is aligned with the mark on the left engine cover. Pull the camshaft chain taut during crankshaft rotation to prevent the chain from snagging.

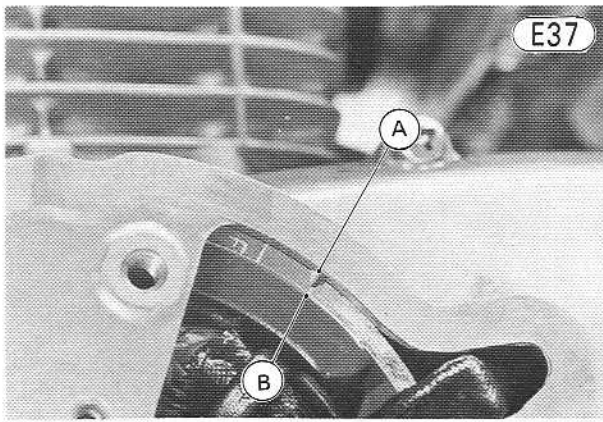

E37

A. Timing Mark B. TDC Mark

- Feed the camshaft through the camshaft sprocket, the slender end of the camshaft first. The notched side of the sprocket should face the slender end.

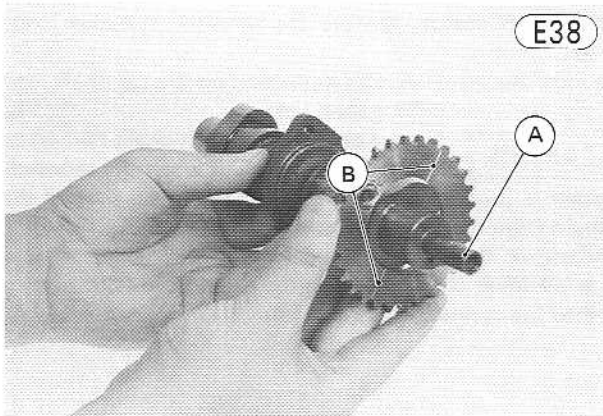

E38

A. Slender End B. Notches

- Feed the camshaft through the camshaft chain, the slender end first, from right to left. Remove the screwdriver or wire that has been used to hold up the chain.
- Check the crankshaft position (E37) and adjust if necessary.
- Fit the camshaft chain onto the sprocket with the notches on the sprocket aligned with the cylinder head surface.

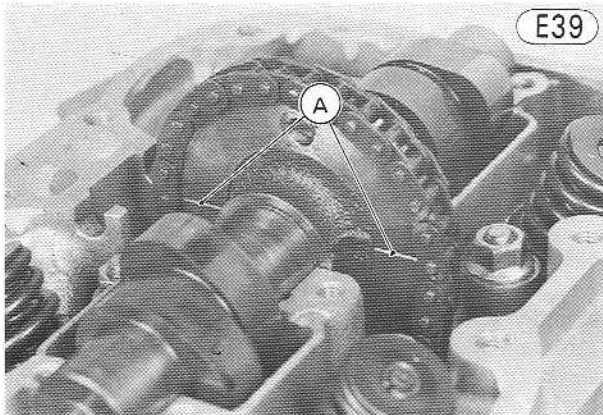

E39

A. Notches

- Turn the camshaft so that the small pin on the sprocket goes up and the mounting holes on the sprocket and camshaft are aligned.

Camshaft Chain Timing

E40

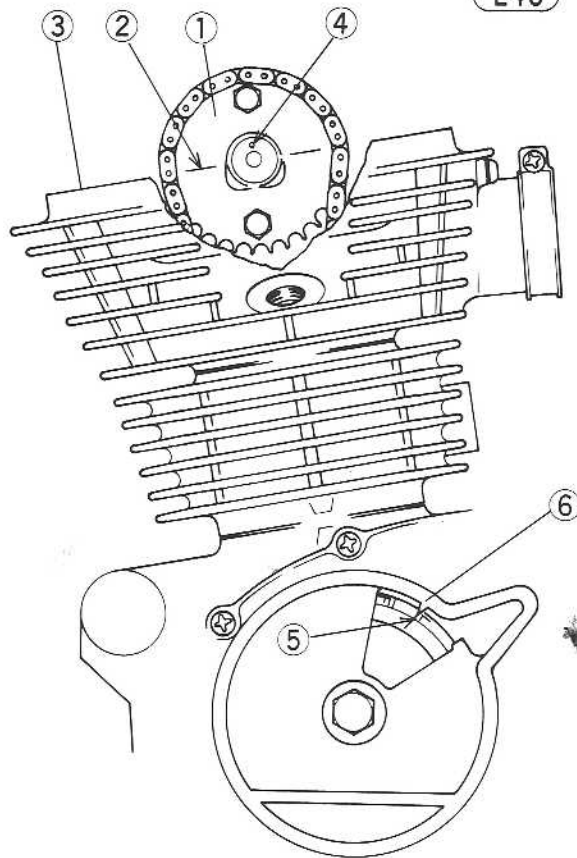

- | | |
|--------------------------|----------------|
| 1. Camshaft Sprocket | 4. Small Pin |
| 2. Notches | 5. TDC Mark |
| 3. Cylinder Head Surface | 6. Timing Mark |

- Apply a non-permanent locking agent to the camshaft sprocket bolts.
- Insert the sprocket bolt. Turn the crankshaft one turn and insert the other sprocket bolt.
- Tighten the sprocket bolts to 1.5 kg-m (11.0 ft-lbs) of torque, using a 14 mm wrench on the crankshaft to hold the camshaft steady.
- Fit the front camshaft chain guide into the cylinder head.
- Install the chain tensioner assembly.
- Turn the camshaft counterclockwise and check the camshaft chain timing. Correct it if necessary.
- Adjust the camshaft chain (Pg. 16), and install the camshaft chain tensioner cap and O rings.
- Install the cylinder head cover (Pg. 44).
- Adjust the valve clearance (Pg. 16).
- Adjust the ignition timing (Pg. 12).
- Install the fuel tank (Pg. 39).

CYLINDER HEAD

Removal:

- Remove the fuel tank (Pg. 39).
- Remove the carburetors (Pg. 39). Removal of the throttle cables from the carburetors is not necessary, but put the carburetors on the frame to avoid cable stretch or carburetor damage.

- Remove the mufflers (Pg. 44).
- Remove the cylinder head cover (Pg. 44).
- Remove the camshaft (Pg. 47).
- Stuff a piece of clean cloth into the cylinder head hole so that no parts or dirt will fall into the cylinder block.
- Remove the cylinder head nuts (8).
- Pull off the cylinder head. If necessary, use a slot screwdriver in the pry points provided under the cylinder head.

CAUTION Do not hammer on the screwdriver to pry off the cylinder head. Doing so may result in cylinder block damage.

Cylinder Head Pry Points

E41

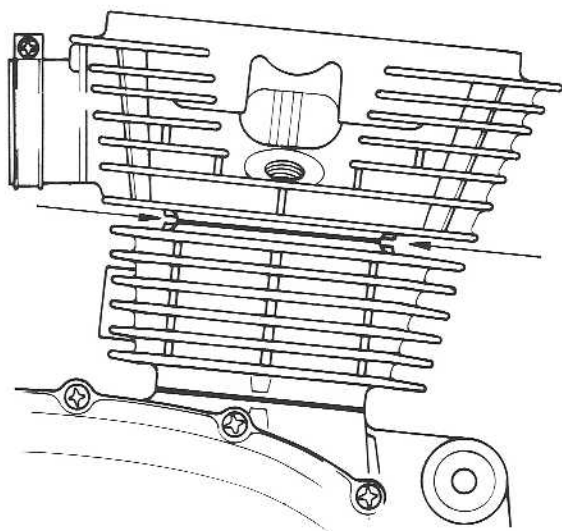

- Use a screwdriver or wire to keep the cam chain from falling down into the cylinder block.

Installation:

- Using compressed air, blow out any particles that may obstruct the oil passages.

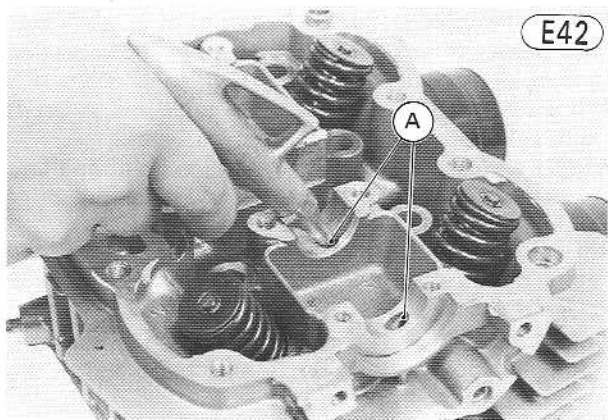

A. Oil Passages

- Make sure that the gasket, knock pins (2), and O rings (2) are properly in place.

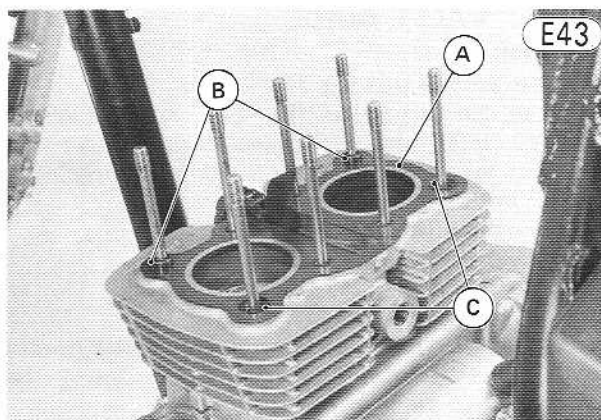

A. Gasket

B. Knock Pins

C. O Rings

- Before installing the cylinder head, pull up the camshaft chain and feed it through the cylinder head hole.
- Install the cylinder head. Use a screwdriver or wire to keep the chain from falling down into the cylinder block.
- Stuff a piece of cloth into the cylinder head hole so that no parts or dirt will fall into the cylinder block.
- Put on the cylinder head nuts (8). At first tighten the nuts to about 2.0 kg-m (14.5 ft-lbs), then tighten them to 2.5 kg-m (18.0 ft-lbs) of torque. Follow the nut tightening order embossed on the cylinder head.

Cylinder Head Nuts Tightening Order

E44

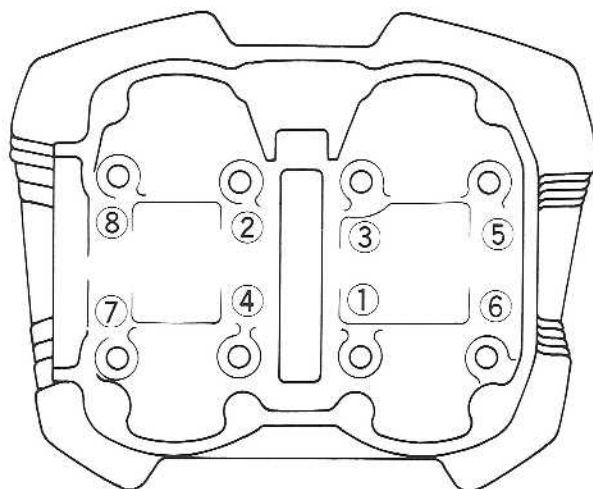

- Install the camshaft (Pg. 47).
- Adjust the camshaft chain (Pg. 16), and install the camshaft chain tensioner cap and O ring.
- Install the cylinder head cover (Pg. 44).
- Adjust the valve clearance (Pg. 16).
- Adjust the ignition timing (Pg. 12).
- Install the carburetors (Pg. 39).
- Install the mufflers (Pg. 44).
- Install the fuel tank (Pg. 39).

50 DISASSEMBLY—ENGINE INSTALLED

VALVE, VALVE GUIDE

Removal:

- Remove the fuel tank (Pg. 39).
- Remove the carburetors (Pg. 39). Removal of the throttle cables from the carburetors is not necessary, but put the carburetors on the frame to avoid cable stretch or carburetor damage.
- Remove the mufflers (Pg. 44).
- Remove the cylinder head cover (Pg. 44).
- Remove the camshaft (Pg. 47).
- Remove the cylinder head (Pg. 48).
- Using the valve spring compressor and adapter (special tools) to press down the valve spring retainer ②, remove the split keeper ①.

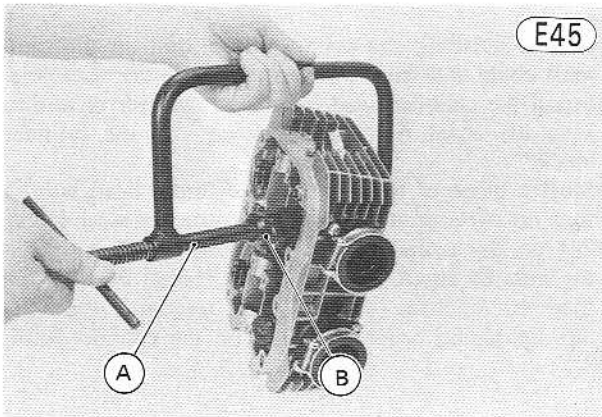

A. Valve Spring Compressor (57001-241)
B. Adapter (57001-1019)

- Remove the tool, and pull out the valve spring retainer, outer spring ③, and inner spring ④.
- Remove the spring seat ⑧.
- Pull out the valve.
- Remove the clip ⑤ and pull off the oil seal.

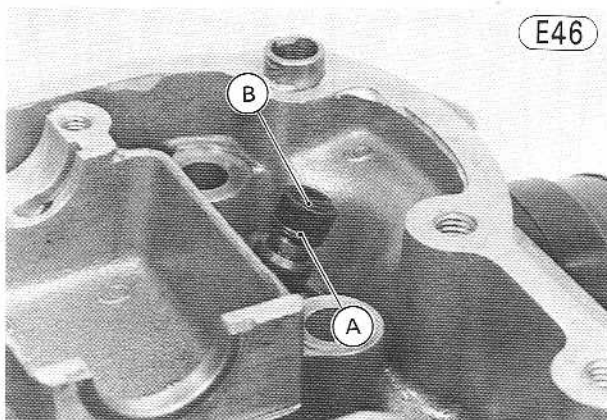

A. Clip
B. Oil Seal

- Heat the area around the guide to about 120~150°C (248~302°F), and hammer lightly on the valve guide arbor (special tool) to remove the guide from the top of the cylinder head.

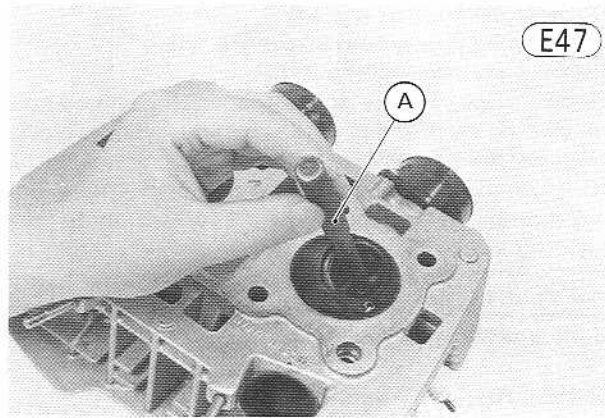

A. Valve Guide Arbor (57001-1021)

Installation:

NOTE: If a new valve guide is installed, the valve to valve guide clearance must be checked (Pg. 124).

- Apply oil to the valve guide.
- Heat the area around the valve guide hole to about 120~150°C (248~302°F), and drive the valve guide in from the top of the head using the valve guide arbor (special tool).
- Ream the valve guide with the valve guide reamer (special tool) even if the old guide is reused.

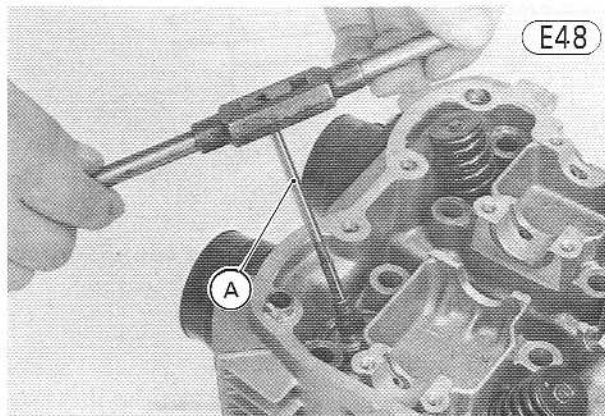

A. Valve Guide Reamer (57001-1020)

- Check the valve seating surface using machinist's dye, and correct if necessary. See page 124 for inspection and repair procedures.
- Fit a new oil seal onto the valve guide and secure it with a clip.
- Apply a small amount of molybdenum disulfide grease to the valve stem, insert the valve, and install the spring seat.
- Install the inner and outer springs. The end with the more closely spaced coils must be placed against the cylinder head.
- Install the spring retainer, press it down with the valve spring compressor assembly (special tool), and fit the split keeper into place.
- After making sure that the split keeper, spring retainer, and valve stem are all properly fitted, remove the valve spring compressor assembly.
- Install the cylinder head (Pg. 48).
- Install the camshaft (Pg. 47).

Valve and Valve Guide

E49

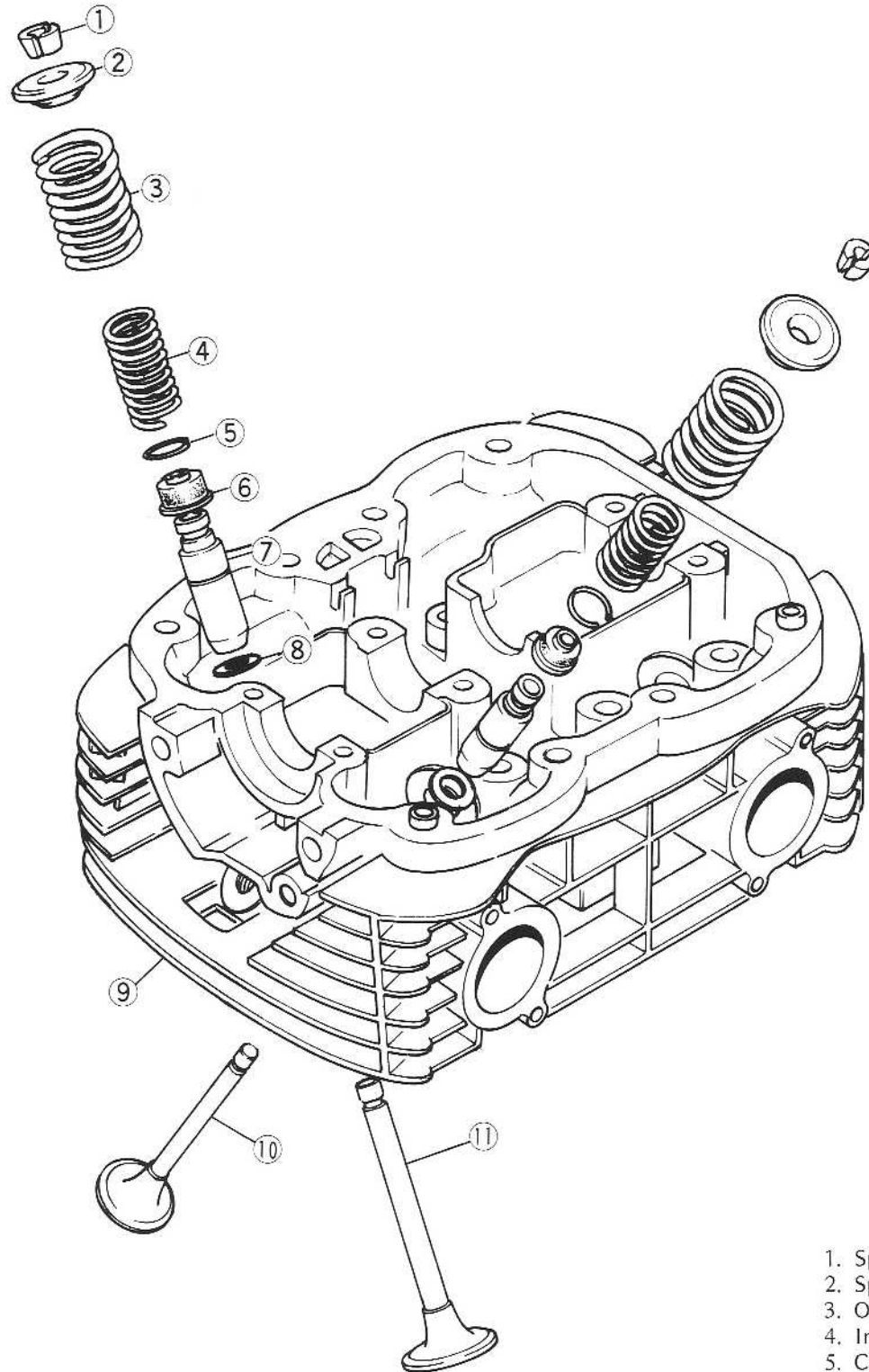

1. Split Keeper
2. Spring Retainer
3. Outer Spring
4. Inner Spring
5. Clip
6. Oil Seal
7. Valve Guide
8. Inner Spring Seat
9. Cylinder Head
10. Inlet Valve
11. Exhaust Valve

52 DISASSEMBLY—ENGINE INSTALLED

- Adjust the camshaft chain (Pg. 16), and install the camshaft chain tensioner cap and O ring.
- Install the cylinder head cover (Pg. 44).
- Adjust the valve clearance (Pg. 16).
- Adjust the ignition timing (Pg. 12).
- Install the carburetors (Pg. 39).
- Install the mufflers (Pg. 44).
- Install the fuel tank (Pg. 39).

CYLINDER BLOCK

Removal:

- Remove the fuel tank (Pg. 39).
- Remove the carburetors (Pg. 39). Removal of the throttle cables from the carburetors is not necessary, but put the carburetors on the frame to avoid cable stretch or carburetor damage.
- Remove the mufflers (Pg. 44).
- Remove the cylinder head cover (Pg. 44).
- Remove the camshaft (Pg. 47).
- Remove the cylinder head (Pg. 48).
- Remove the gasket and O rings on the cylinder block.
- Pull off the cylinder block. If necessary, use a slot screwdriver in the pry points provided on both sides of the cylinder block.

CAUTION Do not hammer on the screwdriver to pry off the cylinder block. Doing so may result in cylinder block or crankcase damage.

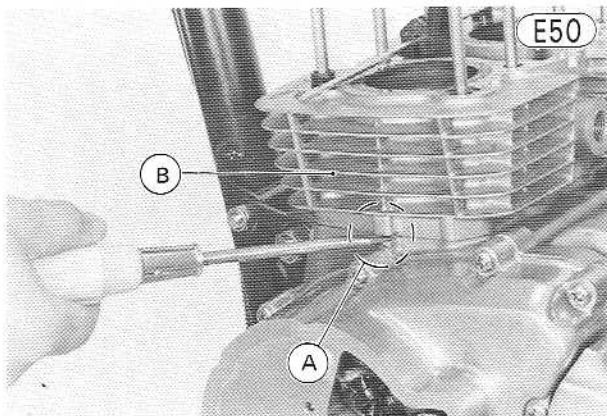

A. Pry Points

B. Cylinder Block

- Wrap a clean cloth around the base of each piston so that no parts or dirt will fall into the crankcase.

Installation:

NOTE: If the cylinder block is replaced with a new one, the piston to cylinder clearance must be checked (Pg. 128).

- Make sure that the two knock pins are properly in place, and fit a new cylinder base gasket.



A. Knock Pins

- Turn the crankshaft until the height of both pistons is the same, while pulling the camshaft chain taut to prevent the chain from snagging.
- To position the pistons during cylinder block installation, use the piston holders (special tools) in the front and rear of the pistons.

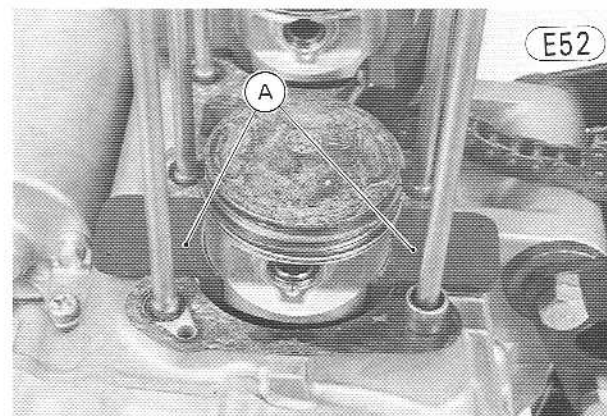

A. Piston Holders (57001-1023)

- Position each piston ring so that the opening in the top and oil ring of each piston is facing forwards, and the second ring opening faces the rear. The openings of the oil ring steel rails must be slipped to both directions about 30° from the opening of the expander.

Piston Rings

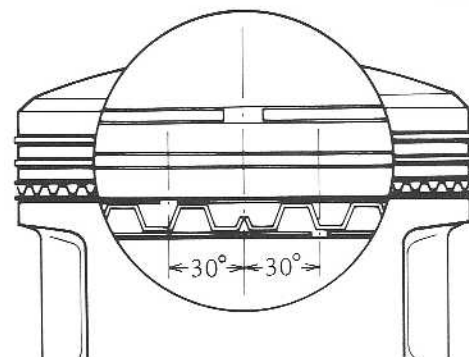

E53

- Apply clean engine oil to the piston rings and cylinder walls.
- Compress the piston rings using piston ring compressor assemblies (special tools).

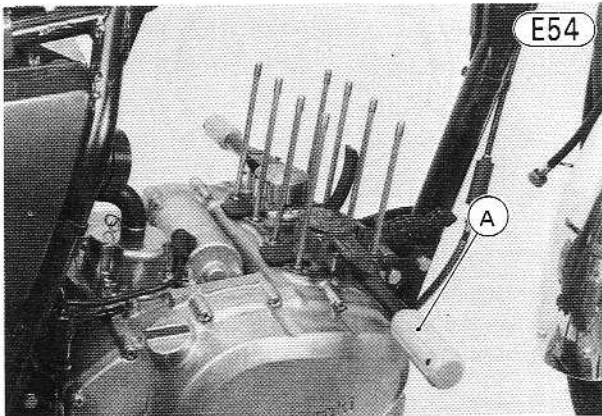

A. Piston Ring Compressor Assembly (57001-921)

- Being careful not to break the piston rings, push the cylinder block down carefully until the bottom of each cylinder clears the piston rings.
- Remove the special tools.
- Push the cylinder block down further until it bottoms.
- Make sure that the two knock pins are properly fitted in the cylinder block.
- Put on the new cylinder head gasket with the wider bore grommets in the gasket facing up.
- Put on the O rings (2). Replace the O rings with new ones if they are deteriorated or damaged.

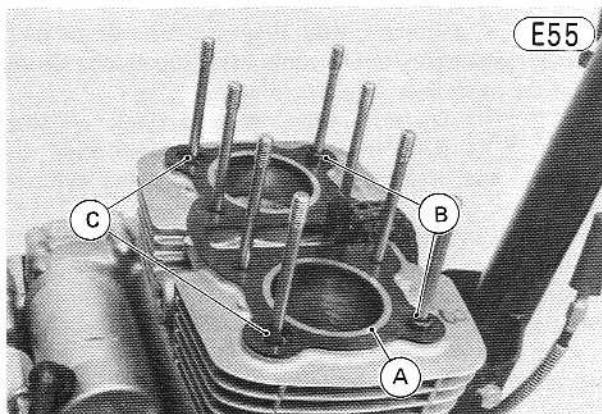

A. Bore Grommet
B. Knock Pins
C. O Rings

- Install the cylinder head (Pg. 48).
- Install the camshaft (Pg. 47).
- Adjust the camshaft chain (Pg. 16), and install the camshaft chain tensioner cap and O ring.
- Install the cylinder head cover (Pg. 44).
- Adjust the valve clearance (Pg. 16).
- Adjust the ignition timing (Pg. 12).
- Install the carburetors (Pg. 39).
- Install the mufflers (Pg. 44).
- Install the fuel tank (Pg. 39).

PISTONS, PISTON RINGS

Removal:

- Remove the fuel tank (Pg. 39).
- Remove the carburetors (Pg. 39). Removal of the throttle cables from the carburetors is not necessary, but put the carburetors on the frame to avoid cable stretch or carburetor damage.
- Remove the mufflers (Pg. 44).
- Remove the cylinder head cover (Pg. 44).
- Remove the camshaft (Pg. 47).
- Remove the cylinder head (Pg. 48).
- Remove the cylinder block (Pg. 52).
- Wrap a clean cloth around the base of each piston to secure it in position for removal and so that no parts or dirt will fall into the crankcase.
- Remove the piston pin snap ring from the outside of each piston.

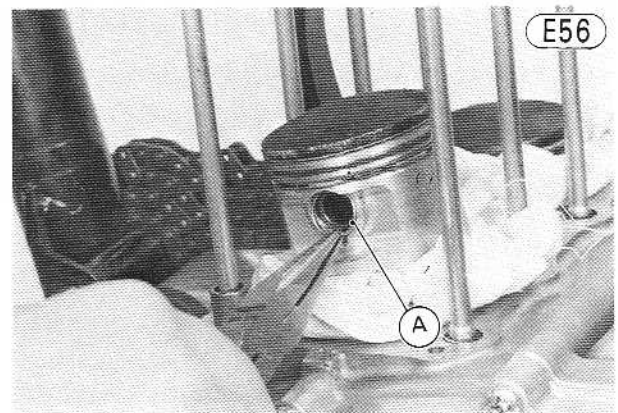

A. Snap Ring

- Remove each piston by pushing its piston pin out the side that the snap ring was removed. If necessary, use the piston pin puller and adapter "B" (special tools).

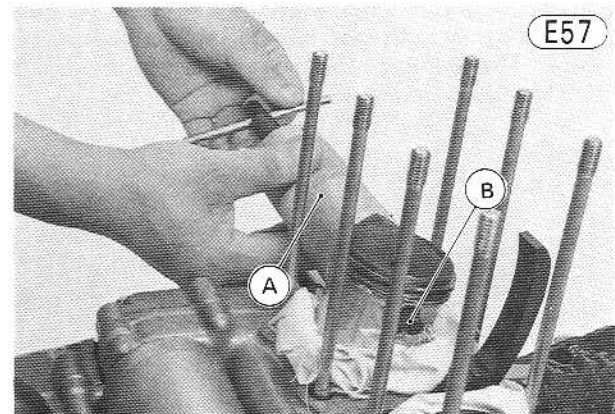

A. Piston Pin Puller (57001-910)
B. Adapter "B" (57001-913)

- Remove the piston rings with the piston ring pliers (special tool). To remove a ring by hand, spread the ring open with both thumbs, and then push up on the opposite side.

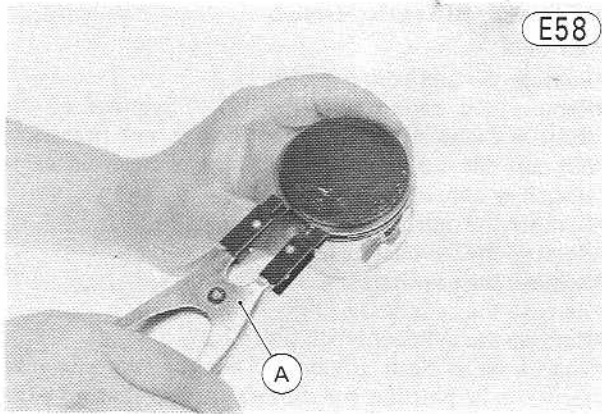

E58

A. Piston Ring Pliers (57001-115)

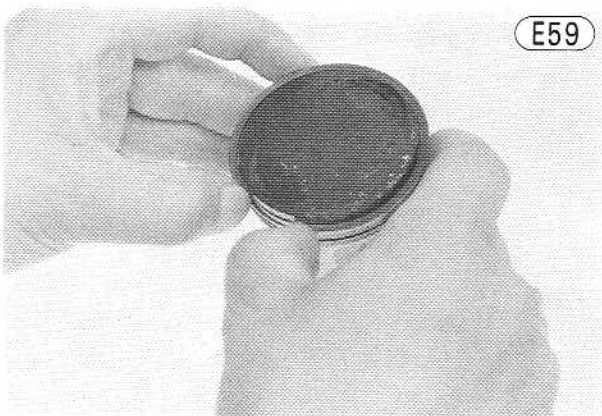

E59

Installation:

NOTE: If the piston is replaced with a new one, check that the piston to cylinder clearance is within the specified value (Pg. 128). Also, check the piston to piston pin clearance whenever a piston or piston pins is replaced (Pg. 130).

- Install the piston rings with the "T" mark on each ring facing up. Do not mix up the top and second rings. The top ring is chrome plated and the second ring is stepped around the lower side.

Piston Rings

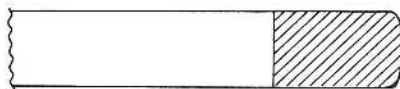

Top Ring

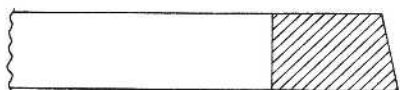

2nd Ring

E60

"T" Mark

E61

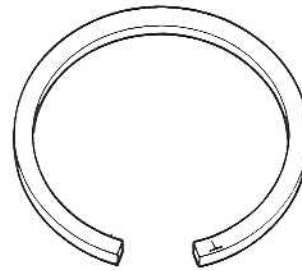

- Apply engine oil to the piston pins, and install the piston and piston pins. The arrow on the top of each piston must point toward the front of the engine.

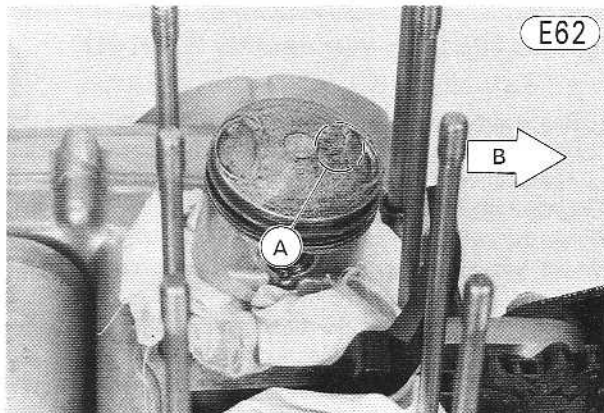

E62

A. Arrow

B. Front

- Fit a new piston pin snap ring into the side of each piston, taking care not to compress it too much. Check that the other snap rings are in place.

CAUTION Do not reuse the snap rings. A snap ring is weakened and deformed by removal, and it may slip out and score the cylinder wall.

- Install the cylinder block (Pg. 52).
- Install the cylinder head (Pg. 48).
- Install the camshaft (Pg. 47).
- Adjust the camshaft chain (Pg. 16), and install the camshaft chain tensioner cap and O ring.
- Install the cylinder head cover (Pg. 44).
- Adjust the valve clearance (Pg. 16).
- Adjust the ignition timing (Pg. 12).
- Install the carburetors (Pg. 39).
- Install the mufflers (Pg. 44).
- Install the fuel tank (Pg. 39).

ENGINE SPROCKET COVER

Removal:

- Remove the mounting bolt and lockwasher, and take off the left footpeg.

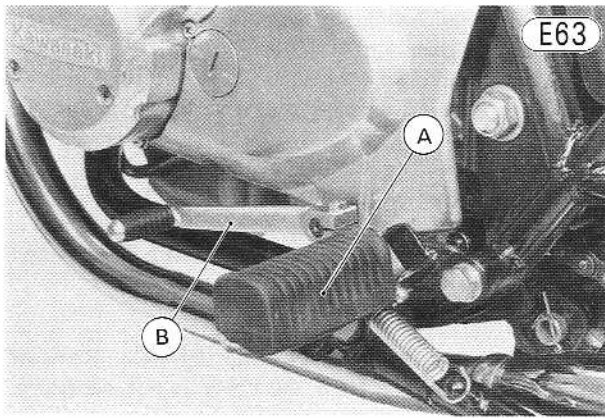

A. Footpeg B. Shift Pedal

- Remove the clamp bolt and take off the shift pedal.
- Remove the screws (4), and pull off the engine sprocket cover.
- Remove the cotter pin, and free the clutch inner cable tip from the clutch release lever and engine sprocket cover.

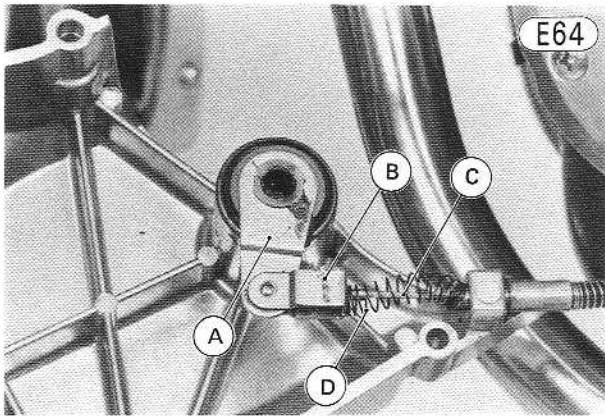

A. Release Lever C. Inner Cable
B. Cotter Pin D. Spring

Installation:

- Feed the clutch cable through the engine sprocket cover and spring, and fit the tip of the inner cable into the clutch release lever.
- Using a new cotter pin, secure the cable tip to the release lever.
- Make sure that the engine sprocket cover knock pins (2) and clutch push rod are in place, and fit the engine sprocket cover.
- Tighten the engine sprocket cover screws (4).
- Install the left footpeg using the bolt and lockwasher.
- Mount the shift pedal with the front of the pedal slightly below the shaft. Insert the bolt and tighten it securely.
- Check the clutch, and adjust if necessary (Pg. 20).

CLUTCH RELEASE

Removal:

- Remove the engine sprocket cover (Pg. 54).
- Remove the clutch release lever and steel ball assembly.

- Unscrew the clutch adjusting cover.
- Remove the clutch adjusting screw locknut, and pull out the adjusting screw and ball ramp plate.

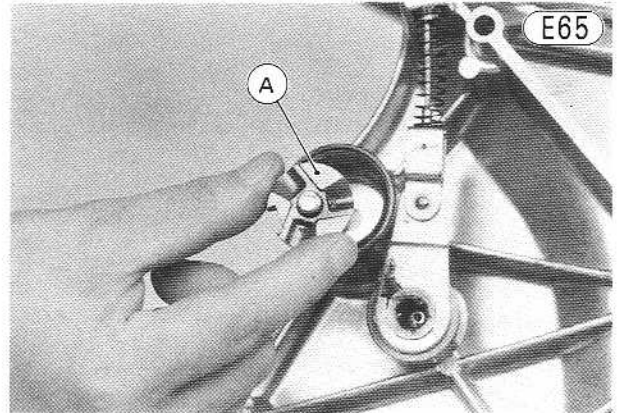

A. Ball Ramp Plate

Installation:

- Wash and clean the clutch release lever, steel ball assembly, and ball ramp with a high flash-point solvent. Dry and lubricate them with grease.
- Install the adjusting screw and ball ramp plate, aligning the ridge on the engine sprocket cover with the groove in the ball ramp plate.

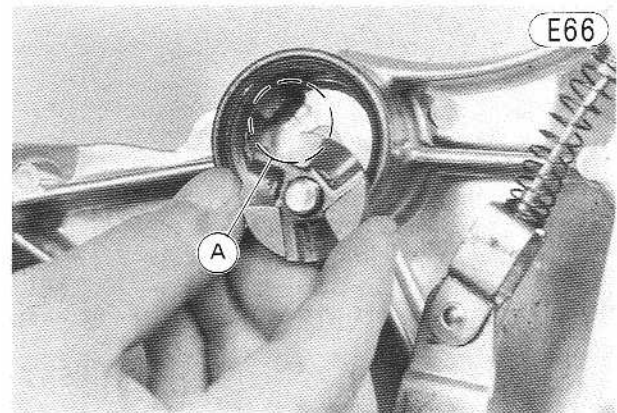

A. Fit the ridge and the groove.

- Install the adjusting screw locknut, finger tight.
- Install the steel ball assembly.
- Apply grease to the grease seal, and install the clutch release lever.
- Install the engine sprocket cover (Pg. 54) and adjust the clutch (Pg. 20).

ENGINE SPROCKET

Removal:

- Remove the engine sprocket cover (Pg. 54). Removal of the clutch cable from the cover is not necessary.
- Remove the drive chain (Pg. 97).
- Straighten the side of the splined washer that is bent over the side of the engine sprocket nut.
- Using the engine sprocket holder (special tool) to hold the engine sprocket steady, loosen the engine sprocket nut. Remove the nut and splined washer.

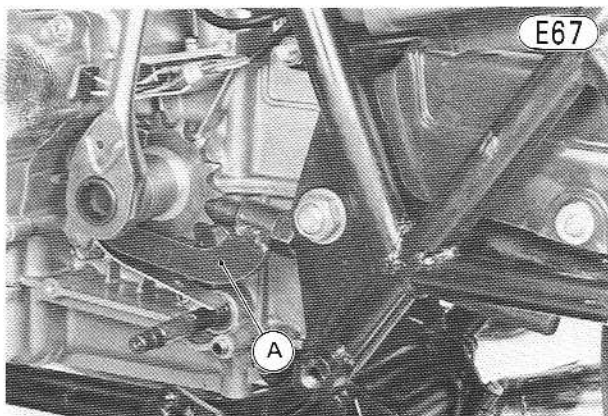

A. Engine Sprocket Holder (57001-307)

- Pull off the engine sprocket.

Installation:

- Fit the engine sprocket and splined washer on the output shaft, and screw on the engine sprocket nut.
- Tighten the nut to 7.0 kg-m (51 ft-lbs) of torque, using the engine sprocket holder (special tool) to hold the engine sprocket steady.
- Bend the part of splined washer over the side of the nut.
- Install the drive chain (Pg. 97).
- Install the engine sprocket cover (Pg. 54).
- Adjust the drive chain (Pg. 24).

STATOR

Removal:

- Remove the engine sprocket cover (Pg. 54). Removal of the clutch cable from the cover is not necessary.
- Disconnect the alternator leads (2).
- Place an oil pan beneath the left engine cover.
- Remove the screws (9), and pull off the left engine cover and gasket.
- Remove the screw, and take off the lead holding plate.

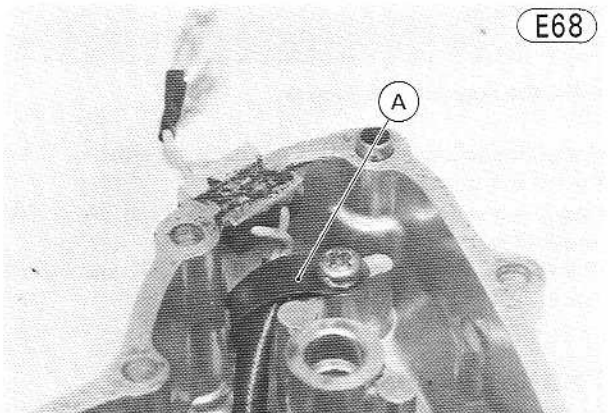

A. Lead Holding Plate

- Remove the screws (3) ⑥, and pull the stator assembly and grommet out of the cover.

Installation:

- Install the grommet, and set the stator assembly into place. Apply a non-permanent locking agent on each screw, and tighten the screws securely.

- Install the lead holding plate, and apply a little liquid gasket to the grommet.
- Make sure that the knock pins (2) are in place, and fit the left engine cover using a new gasket. Tighten the screws (9).
- Connect the alternator leads (2).
- Install the engine sprocket cover (Pg. 54).
- Check the clutch (Pg. 20), and adjust if necessary.
- Check the oil level (Pg. 21), and add more if necessary.

STARTER MOTOR CLUTCH

Removal:

- Remove the engine sprocket cover (Pg. 54). Removal of the clutch cable from the cover is not necessary.
- Disconnect the alternator leads (2).
- Place an oil pan beneath the left engine cover.
- Remove the screws (9), and pull off the left engine cover and gasket.
- Using the flywheel holder (special tool) to hold the crankshaft steady, loosen the bolt on the crankshaft. Remove the bolt.

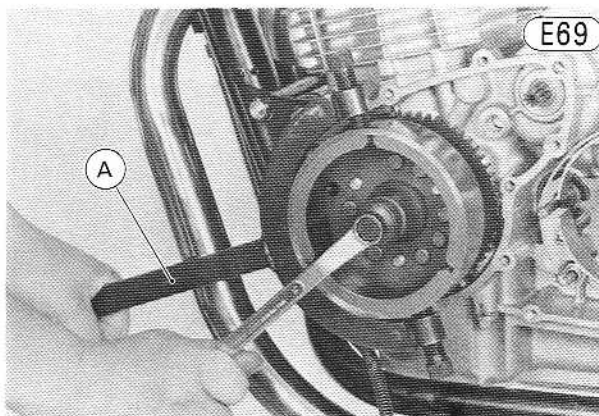

A. Flywheel Holder (57001-308)

- To pull out the rotor and starter motor clutch assembly, first insert the rotor puller adapter (special tool) into the crankshaft hole. Then pull it out using the rotor puller and flywheel holder (special tools). There is a copper washer behind the starter motor clutch.

CAUTION If the rotor is difficult to remove and a hammer is used to tap the rotor puller, be careful not to strike the rotor itself. Striking the rotor can cause the magnets to lose their magnetism.

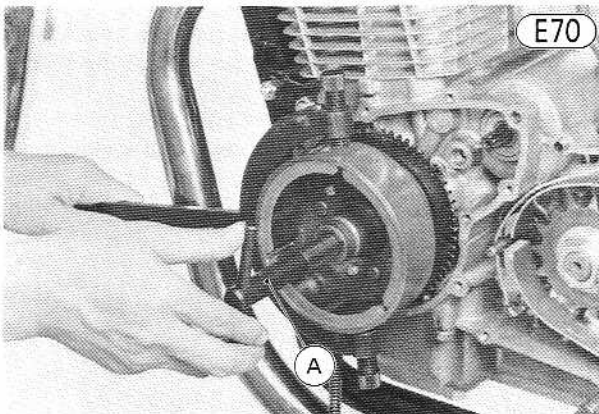

A. Rotor Puller (57001-1016) and Rotor Puller Adapter (57001-1109)

Rotor, Starter Motor Clutch

E71

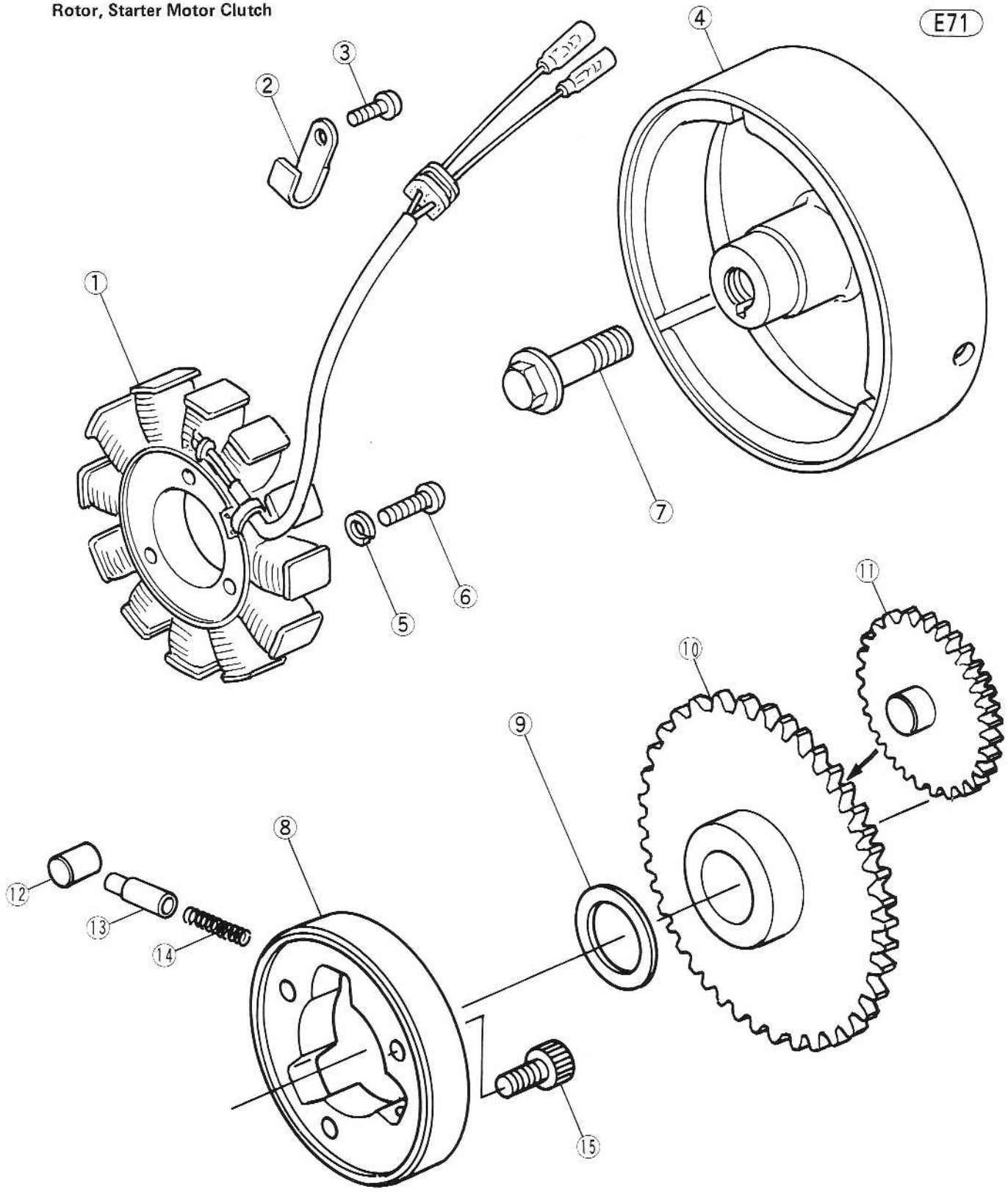

- | | | | |
|-----------------------|-------------------------|------------------------|----------------|
| 1. Stator | 5. Lockwasher | 9. Copper Washer | 13. Spring Cap |
| 2. Lead Holding Plate | 6. Screw | 10. Starter Drive Gear | 14. Spring |
| 3. Screw | 7. Rotor Bolt | 11. Starter Idler Gear | 15. Allen Bolt |
| 4. Rotor | 8. Starter Motor Clutch | 12. Roller | |

58 DISASSEMBLY—ENGINE INSTALLED

Installation:

- Using a high flash-point solvent, clean off any oil or dirt that may be on the crankshaft taper or rotor hub.
- Apply engine oil to the starter drive gear boss.
- Make sure that the woodruff key is properly fitted and that the copper washer is attached on the crankshaft, and fit the rotor and starter clutch assembly on the crankshaft. Turning the starter drive gear clockwise during this procedure will help the rollers in the clutch fit properly.

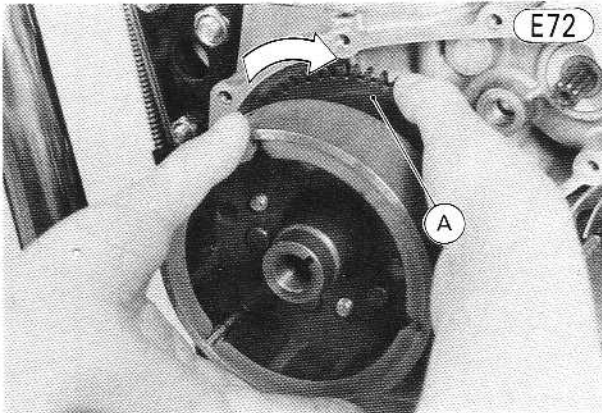

A. Starter Drive Gear

- Tighten the rotor bolt to 7 kg-m (51 ft-lbs) of torque, using the flywheel holder (special tool) to hold the crankshaft steady.
- Make sure that the knock pins (2) are in place, and fit the left engine cover using a new gasket. Tighten the screws (9).
- Connect the alternator leads (2).
- Install the engine sprocket cover (Pg. 54).
- Check the clutch (Pg. 20), and adjust if necessary.
- Check the oil level (Pg. 21), and add more if necessary.

Disassembly:

- Remove the rollers, springs, and spring cap (3 ea) from the starter motor clutch.

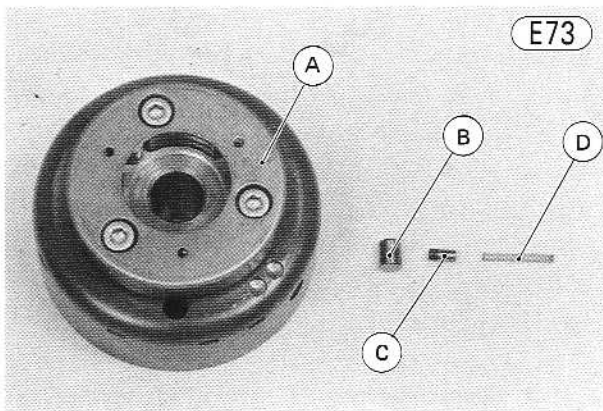

A. Starter Motor Clutch
B. Roller

C. Spring Cap
D. Spring

- Using the flywheel holder (special tool) to hold the rotor steady, remove the Allen bolts (3) to separate the starter motor clutch from the rotor.

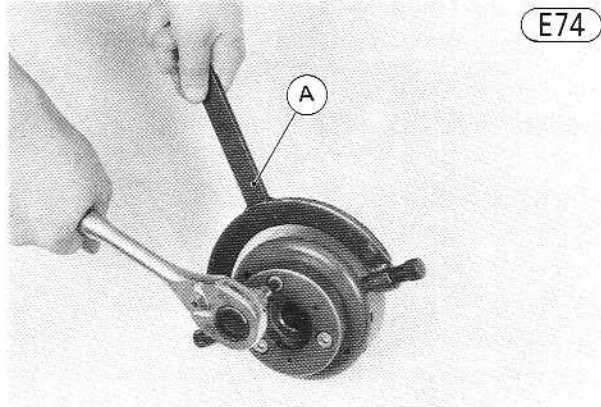

A. Flywheel Holder (57001-308)

Assembly Note:

- Apply a non-permanent locking agent to the starter motor clutch Allen bolts (3), and tighten the bolts to 3.5 kg-m (25 ft-lbs) of torque.

STARTER MOTOR

Removal:

- Remove the engine sprocket cover (Pg. 54). Removal of the clutch cable from the cover is not necessary.
- Disconnect the alternator leads.
- Place an oil pan beneath the left engine cover.
- Remove the screws (9), and pull off the left engine cover and gasket.
- Slide off the rubber boot, and loosen the starter motor terminal nut.

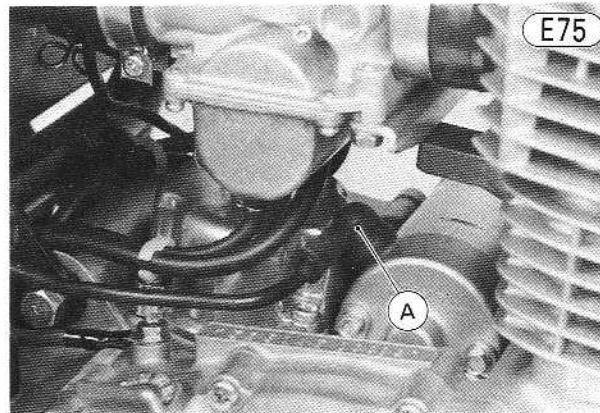

A. Rubber Boot

- Remove the camshaft chain tensioner cap.
- Loosen the carburetor holder clamp screws, and slide the carburetors off toward the air cleaner housing.
- Remove the starter motor retaining bolts (2).
- Pry the starter motor loose from the crankcase with a screwdriver, and slide it off.

CAUTION

Do not tap on the starter motor shaft. Tapping on the shaft may damage the motor.

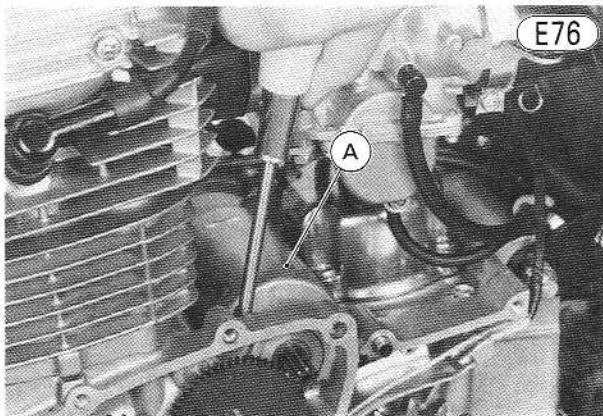

A. Starter Motor

- Remove the starter motor terminal nut and lockwasher, and free the lead from the motor.

Starter Motor

Installation:

- Replace the O ring with a new one, if it is deteriorated or damaged, and apply a little oil to it.
- Clean the starter motor lugs and crankcase where the starter motor is grounded.

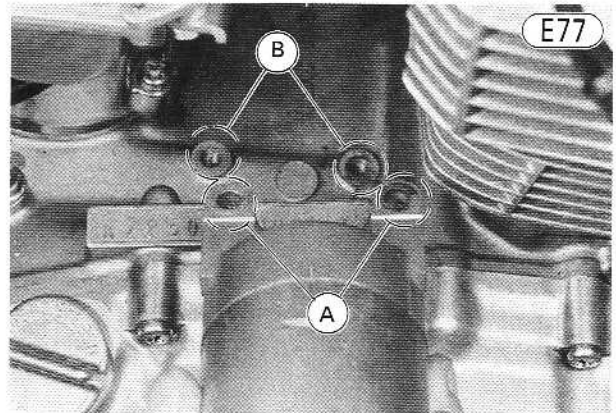

A. Starter Lugs

B. Lug Mounting Surfaces

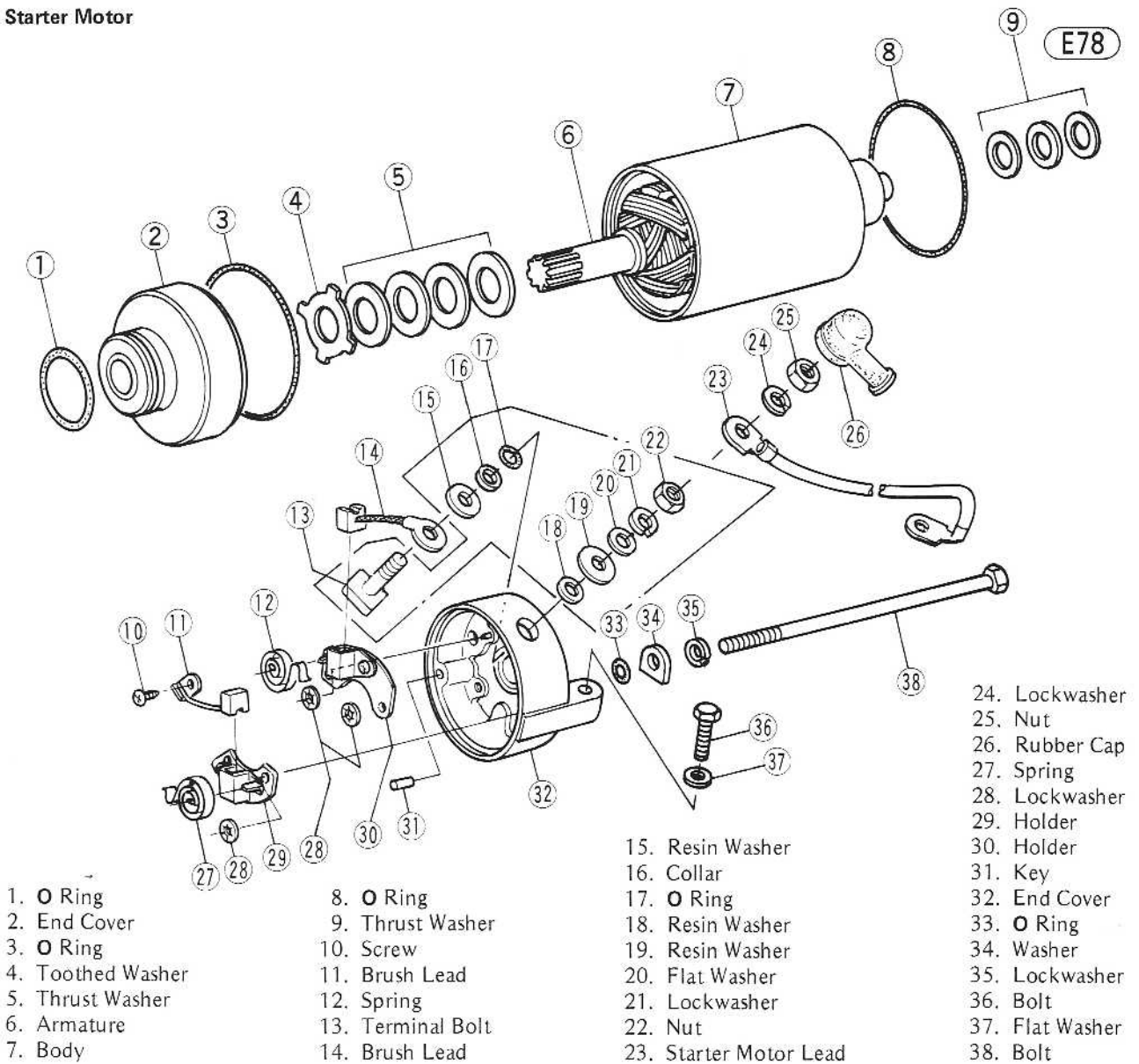

60 DISASSEMBLY—ENGINE INSTALLED

- Push the starter motor back into position with the pinion on the motor meshed with the idler gear.
- Connect the starter motor lead to the terminal with its lockwasher and nut. Do not tighten the nut yet.
- Apply a non-permanent locking agent to the starter motor mounting bolts, and tighten the bolts to 1.0 kg-m (7 ft-lbs) of torque.
- Tighten the starter motor terminal nut, and slide back the rubber boot.
- Install the camshaft chain tensioner cap and O ring.
- Slide the carburetors back into place, and tighten the carburetor holder clamp screws (2).
- Check that the knock pins (2) are in place, install the left engine cover using a new gasket, and tighten its screws (9).
- Connect the alternator leads.
- Install the engine sprocket cover (Pg. 54).
- Check the oil level (Pg. 21), and add more if necessary.

Disassembly:

- Remove the bolts (38), lockwashers (35), washers (34), and O rings (33) (2 ea), and pull off the end covers (2), (32).
- Remove the toothed washer (4), shims (5), and resin washer from the pinion side.
- Remove the shim (9), and resin washer (9) from the terminal side.
- Remove the screw (10) which connects the brush lead (11) to the end cover.

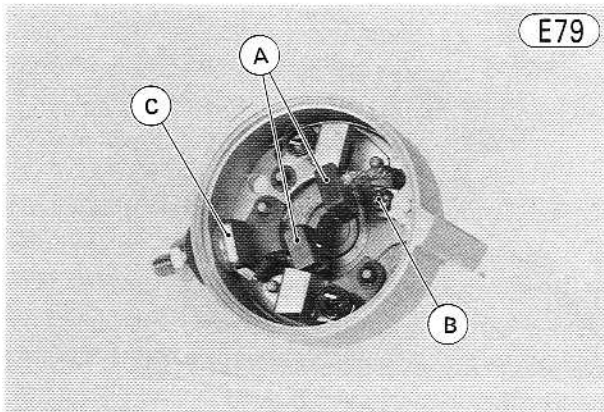

A. Brushes B. Screw C. Terminal Bolt

- Remove the terminal nut (22), lockwasher (21), flat washer (20), large resin washer (19), and small resin washer (18), and pull out the terminal bolt assembly from the end cover.
- Remove the O ring (17), collar (16), resin washer (15), flat washer, and brush lead from the bolt.

Assembly Notes:

1. Replace any O rings that are deteriorated or damaged with new ones.
2. Install the terminal side end cover, while holding the brushes with a suitable tool to fit the brushes on the segments.

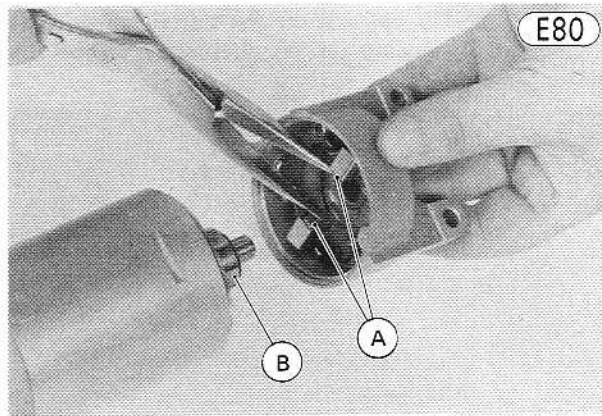

A. Brushes B. Segments

3. Align the lines on the end covers with the lines on the housing.

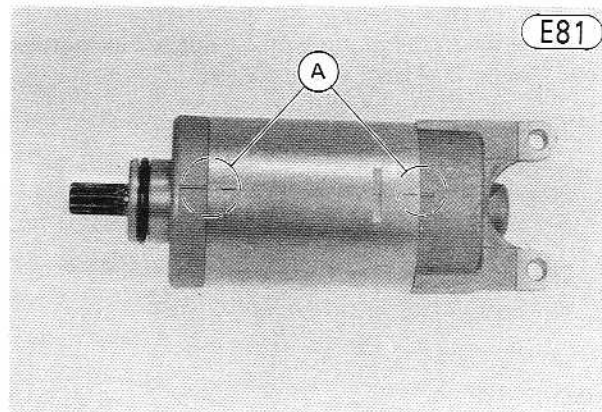

A. Lines

CONTACT BREAKER

Removal:

- Pull off the left spark plug lead.
- Remove the screws (2) and take off the contact breaker cover and gasket.
- Remove the contact breaker base screws (2). Each screw has a lockwasher and flat washer.

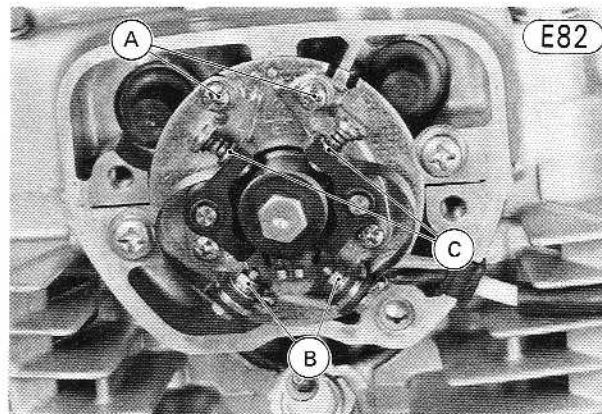

A. Base Screws B. Terminal Nut C. Contact Breaker

- Remove the contact breaker terminal bolt, and free the contact breaker from the engine.

Installation Notes:

1. The sequence of installation on the contact breaker terminal bolt is: flat washer (5), contact breaker lead (11), spring (6), larger insulator (7), small insulator (8) (in contact breaker hole), large insulator (10), flat washer (12), lockwasher (13), and nut (14).
2. When installing the contact breaker, fit the contact breaker base pin into the hole on the mounting plate.

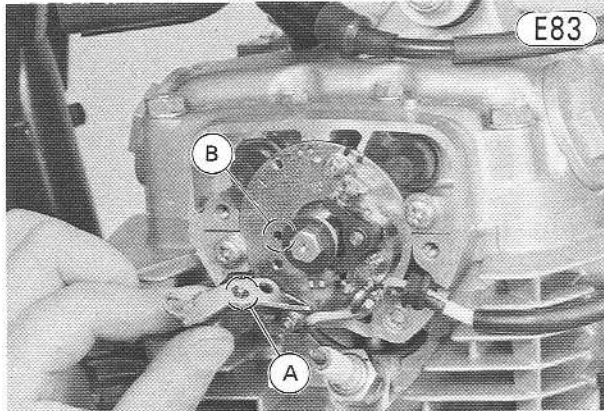

A. Pin B. Hole

3. After installation, adjust the ignition timing (Pg. 12).

Contact Breaker Lead Installation

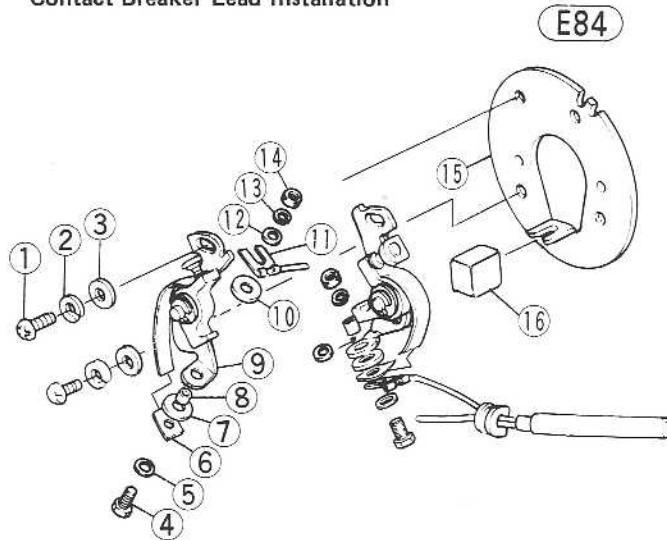

- | | |
|-------------------------|------------------------------------|
| 1. Screw | 10. Large Insulator |
| 2. Lockwasher | 11. Contact Breaker Lead |
| 3. Washer | 12. Washer |
| 4. Bolt | 13. Lockwasher |
| 5. Washer | 14. Nut |
| 6. Spring | 15. Contact Breaker Mounting Plate |
| 7. Large Insulator | 16. Felt |
| 8. Small Insulator | |
| 9. Contact Breaker Base | |

TIMING ADVANCER

Removal:

- Pull off the left spark plug lead.
- Remove the contact breaker cover and gasket.
- Remove the mounting screws (2) and take off the contact breaker mounting plate.
- Remove the alternator cover.
- Using a 14 mm wrench on the crankshaft to hold the camshaft steady, loosen the bolt on the camshaft. Remove the bolt, flat washer, and timing advancer.

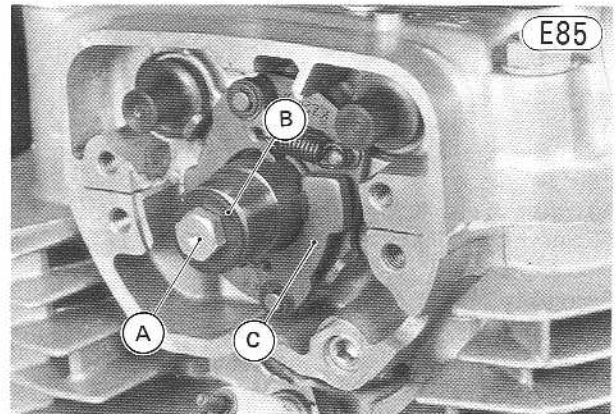

A. Bolt B. Flat Washer C. Timing Advancer

Installation:

- Fit the timing advancer onto the camshaft, matching its notch with the pin on the camshaft. Insert the bolt and flat washer, and tighten the bolt to 1.0 kg-m (7 ft-lbs) of torque.

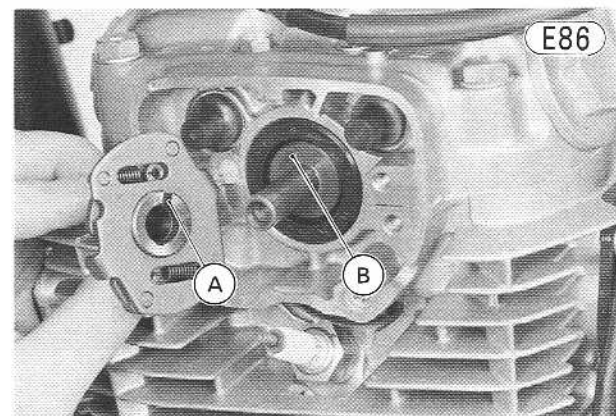

A. Notch B. Pin

- Install the contact breaker mounting plate, flat washers and screws. Apply a liquid gasket around the rubber grommet and fit the grommet into place.
- Adjust the ignition timing (Pg. 12).
- Install the contact breaker cover and gasket.
- Install the alternator cover.
- Connect the spark plug lead.

Disassembly:

- Turn the cam counterclockwise and pull off the cam.

62 DISASSEMBLY—ENGINE INSTALLED

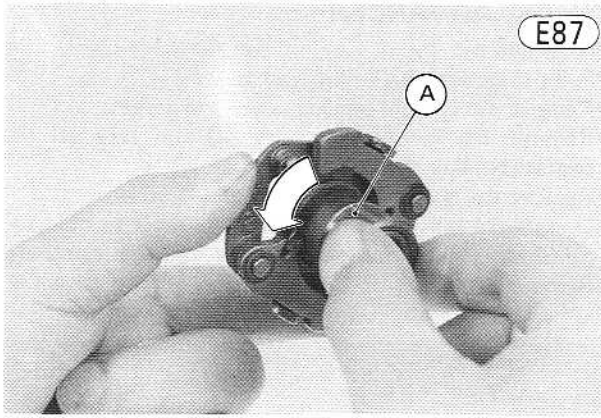

A. Cam

- Remove the E rings and flat washers, and remove the weights.
- Remove the washer from each weight pivot.
- Remove the shim from the sleeve.

Assembly Notes:

1. Wipe the advancer clean, and fill the groove inside the cam with high temperature synthetic grease (same quality as N.L.G.I.-II, applicable temperature of -73~220°C). Our recommendation is the fluorine base *Barrierta L55/2*, manufactured by *Kluber Lubrication, Munchen K.G.*

CAUTION If a low quality grease is applied in the cam, it will easily vaporize due to the high temperature in the cylinder head, and become hard, resulting in timing advancer binding.

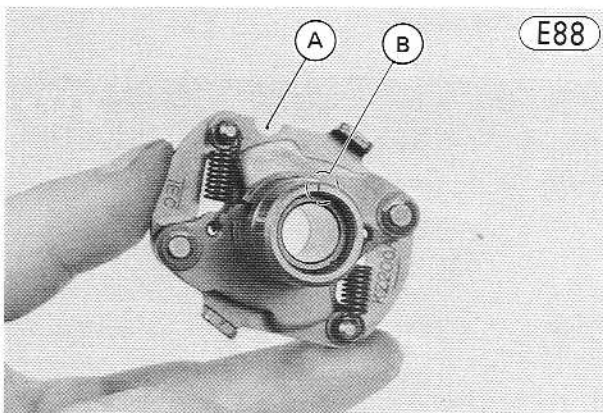

A. Notch

B. Mark

2. Install the cam on the advancer with the mark on the cam pointing to the notch.

NOTE: If the cam is incorrectly installed, the correct ignition timing cannot be obtained.

RIGHT ENGINE COVER

Removal:

- With the motorcycle on its center stand, place an oil pan beneath the engine, and remove the engine drain plug to drain out the oil.

- After draining the oil, insert the drain plug with its gasket and tighten it to 3.0 kg-m (22 ft-lbs) of torque.
- Remove the mounting bolt and lockwasher, and take off the right footpeg.
- Remove the screws (14) and pull off the right engine cover and gasket.

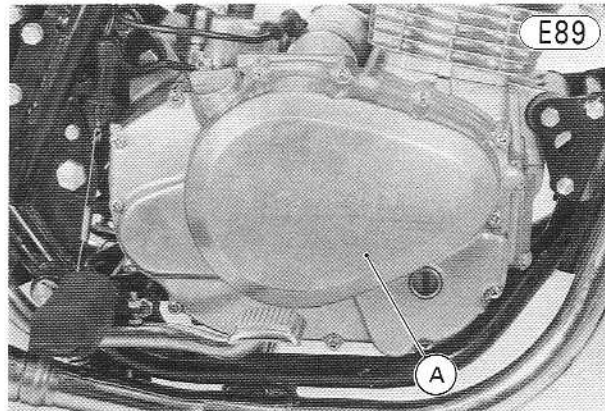

A. Right Engine Cover

Installation:

- Install a new right engine cover gasket.
- Make sure that the two knock pins are in place, and fit the right engine cover on the crankcase.
- Insert the screws (14) and tighten them securely.
- Install the right footpeg, bolt, and lockwasher.
- Fill the engine with oil.

CLUTCH

Removal:

- Remove the right engine cover (Pg. 62).
- Remove the clutch spring bolts ②②, washers ②②, and springs ②① (5 ea).

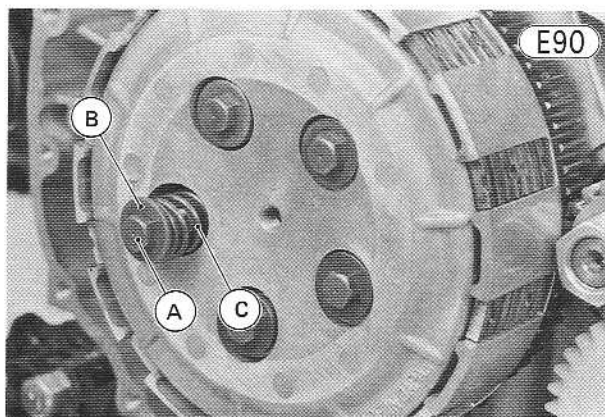

A. Bolt

B. Washer

C. Spring

- Remove the spring plate ②① and spring plate pusher ①⑨.
- Remove the friction plates ①③ (7) and steel plates ①④ (6).
- Straighten the part of the toothed washer that is bent over the side of the clutch hub nut.
- Using the clutch holder (special tool) to hold the clutch hub steady, loosen the clutch hub nut. Remove the clutch hub nut ①⑧ and toothed washer ①⑦.

Clutch

E91

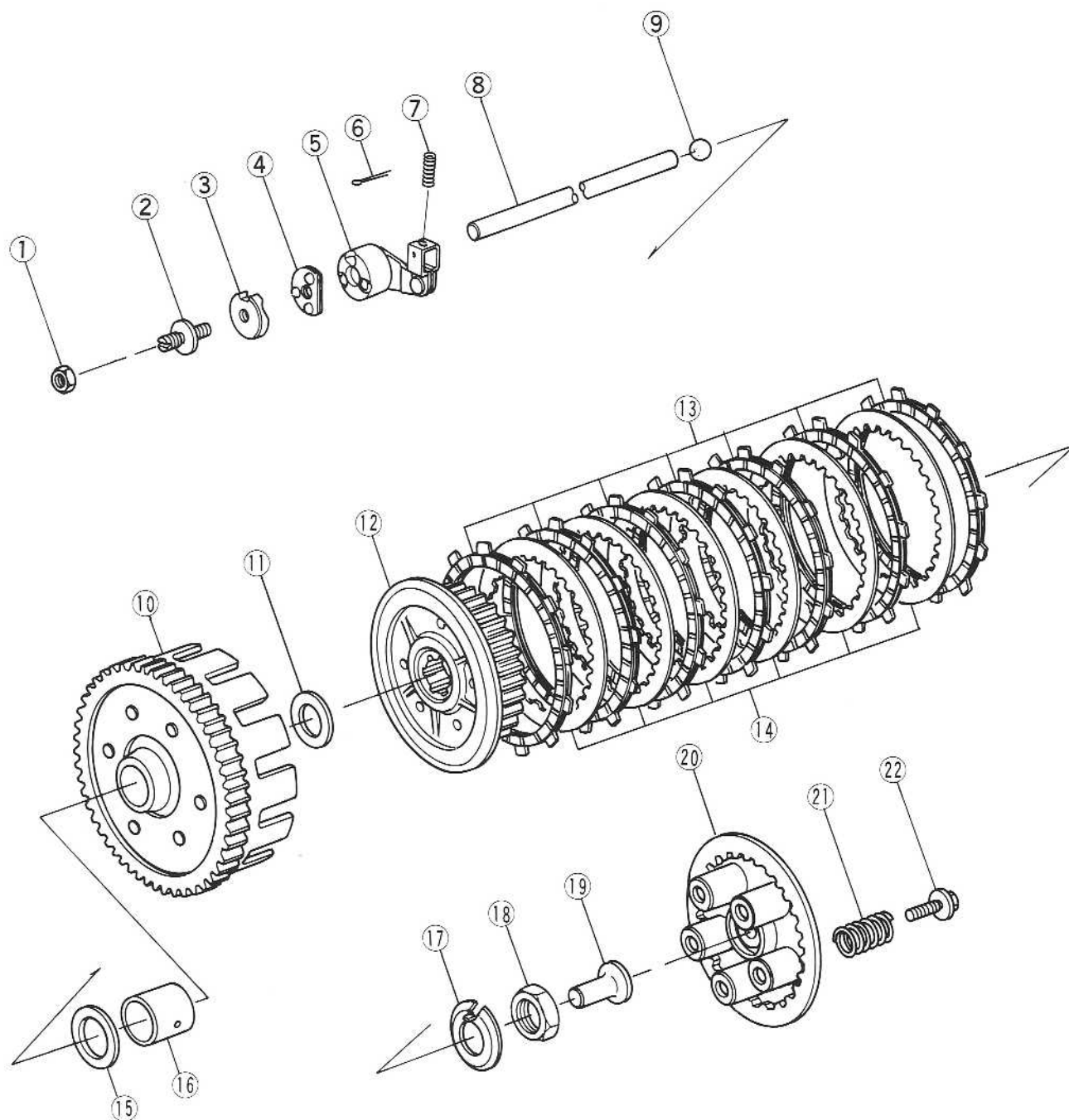

1. Locknut
2. Adjusting Screw
3. Ball Ramp Plate
4. Ball Assembly
5. Release Lever
6. Cotter Pin

7. Spring
8. Push Rod
9. Steel Ball
10. Clutch Housing
11. Thrust Washer
12. Clutch Hub

13. Friction Plate
14. Steel Plate
15. Spacer
16. Sleeve
17. Toothed Washer
18. Nut

19. Spring Plate Pusher
20. Spring Plate
21. Spring
22. Bolt

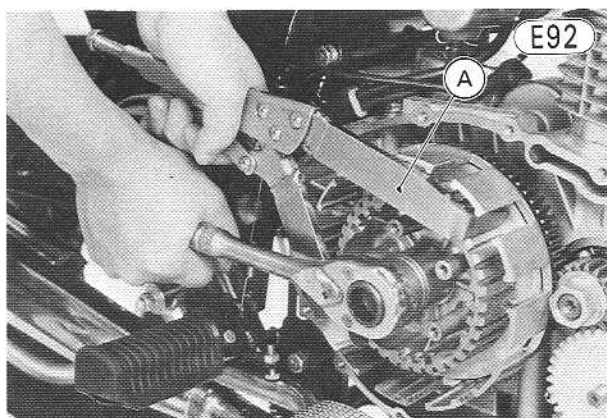

A. Clutch Holder (57001-305)

- Pull off the clutch hub (12), thrust washer (11), clutch housing (10), sleeve (16), and spacer (13).

Installation:

- Put the spacer and sleeve on the drive shaft.
- Apply engine oil to the clutch gear and in the clutch housing hub.
- Fit the clutch housing so that the clutch housing gear meshes with the primary gear.
- Put on the thrust washer and clutch hub.
- Put on the toothed washer so that its tooth fits into the hole in the clutch hub. Screw on the clutch hub nut.

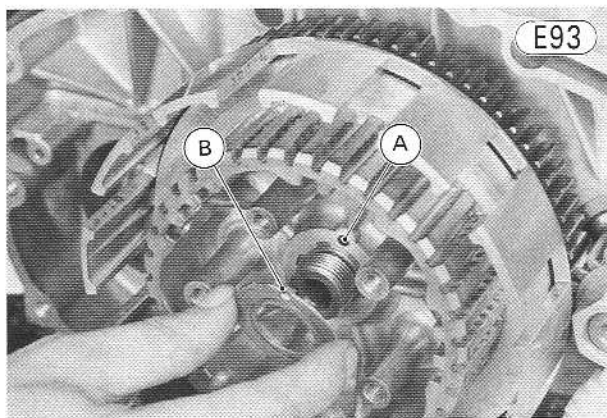

A. Hole B. Tooth

- Tighten the clutch hub nut to 12.0 kg-m (87 ft-lbs) of torque, using the clutch hub holder (special tool) to hold the clutch hub steady.
- Bend the part of toothed washer over the side of the clutch hub nut.
- Fit the friction plates (7) and steel plates (6), starting with a friction plate and alternating them.

CAUTION If the new dry plates are used, apply engine oil to the plates to avoid clutch plate seizure.

- Make sure that the steel ball is placed in the drive shaft. Apply a small amount of molybdenum disulfide grease to the spring plate pusher, and fit it into the drive shaft.

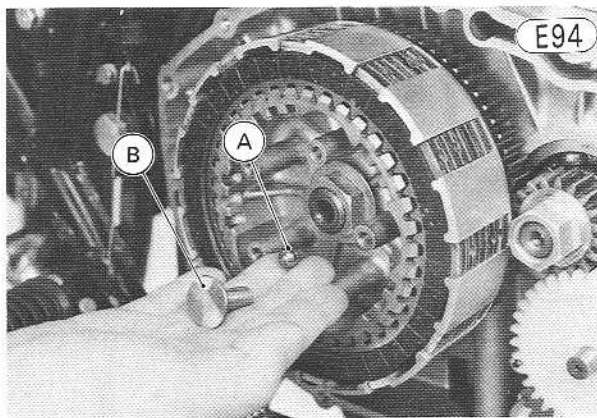

A. Steel Ball B. Spring Plate Pusher

- Install the spring plate, springs, washers, and bolts (5 ea). Crosstighten the bolts evenly to 1.0 kg-m (87 in-lbs) of torque.
- Install the right engine cover (Pg. 62).
- Adjust the clutch (Pg. 20).

OIL PUMP

Removal:

- Remove the right engine cover (Pg. 62).
- Pull the oil pump drive gears out of place.

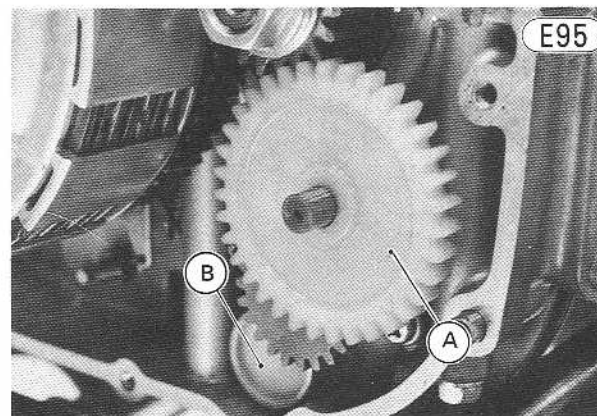

A. Oil Pump Drive Gear B. Oil Pump

- Remove the mounting screws (5) (2), and pull off the oil pump.

Installation Notes:

1. Fill the oil pump with oil for initial lubrication.
2. Before installing the oil pump, check to see that the knock pins (2) are in place.
3. Apply a small amount of molybdenum disulfide grease to the shaft portion of the oil pump drive gears.

Disassembly:

- Remove the E ring, and pull out the oil pump gear.
- Pull out the inner and outer rotors (2, 3).

Assembly Notes:

1. Make sure that the knock pins are in place.
2. After completing the oil pump assembly, make sure that the rotor shaft and rotors turn smoothly.

Oil Pump

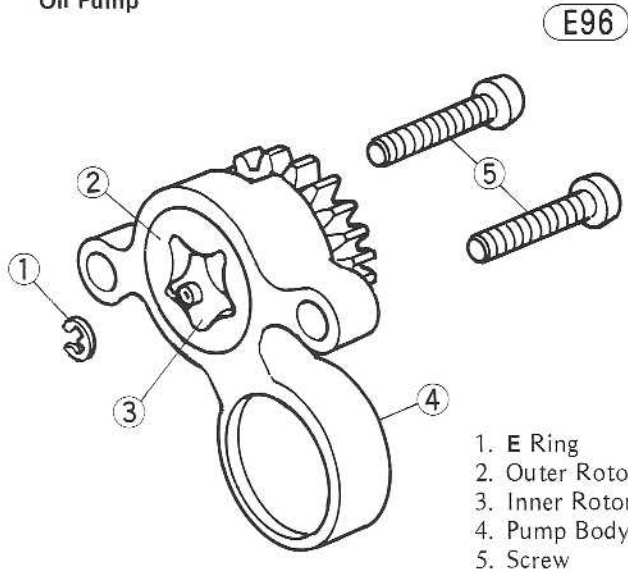

1. E Ring
2. Outer Rotor
3. Inner Rotor
4. Pump Body
5. Screw

EXTERNAL SHIFT MECHANISM

Removal:

- Remove the engine sprocket cover (Pg. 54). Removal of the clutch cable from the cover is not necessary.
- Remove the screws (3) and take off the drive chain guard.

NOTE: These two steps are necessary to use the shift shaft oil seal guide (special tool) when the external shift mechanism is installed.

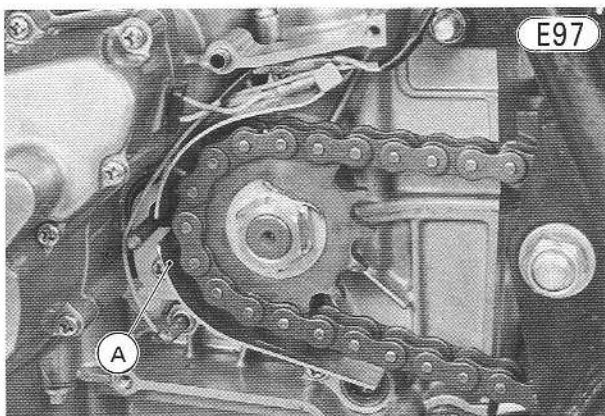

A. Drive Chain Guard

- Remove the right engine cover (Pg. 62).
- Remove the clutch (Pg. 62).
- Move the shift arm and overshift limiter out of the shift drum, and pull out the external shift mechanism.

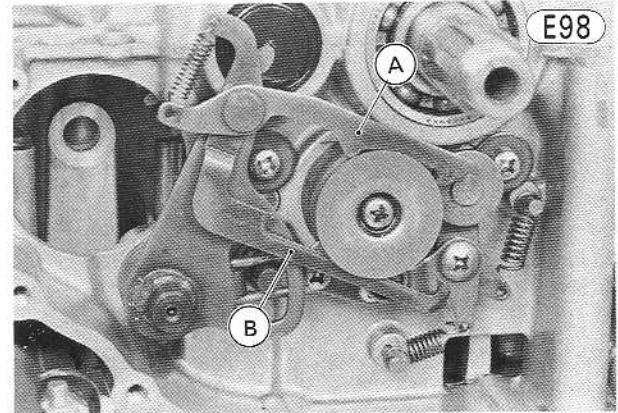

A. Shift Arm B. Overshift Limiter

- Remove the collar and return spring.

External Shift Mechanism

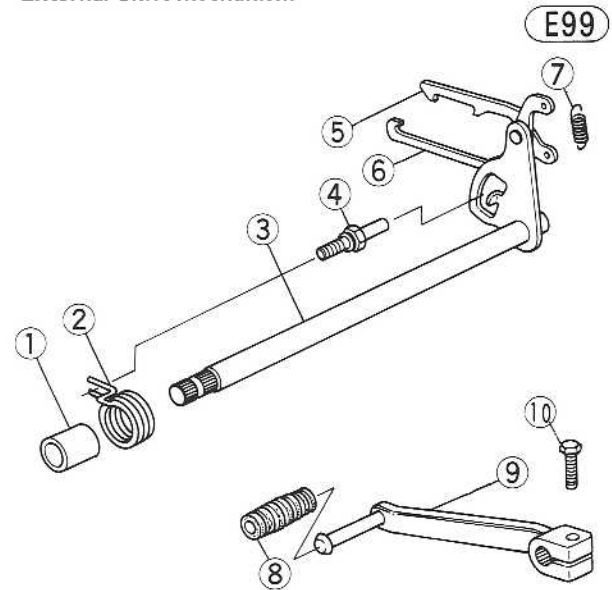

1. Collar
2. Spring
3. Shift Shaft
4. Return Spring Pin
5. Shift Mechanism Arm
6. Over Shift Limiter
7. Arm Spring
8. Pedal Rubber
9. Shift Pedal
10. Bolt

Installation:

- Make sure that the return spring pin is not loose. If it is loose, remove it, apply a non-permanent locking agent to the threads, and install it.
- Fit the collar and return spring on the shift shaft. Make sure that the arm spring is installed on the two arms.

66 DISASSEMBLY—ENGINE INSTALLED

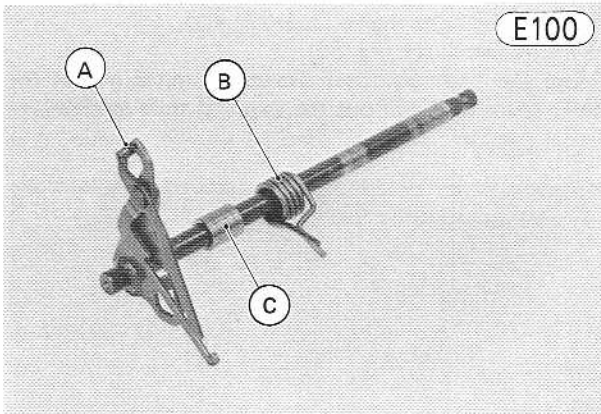

A. Arm Spring
B. Return Spring
C. Collar

- Fit the shift shaft oil seal guide (special tool) in the crankcase oil seal. Then install the shift mechanism with the ends of the return spring fitted on the pin and the two arms on the shift drum.

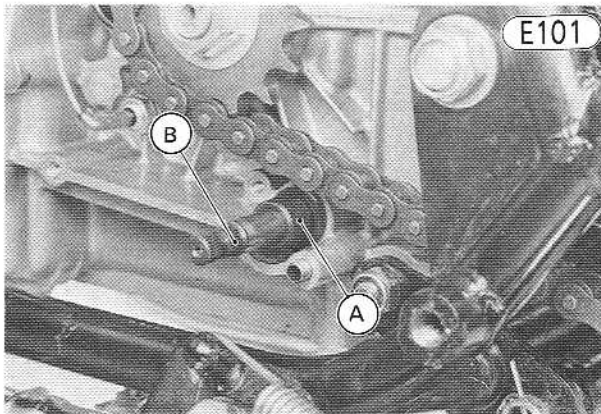

A. Oil Seal Guide (57001-264)
B. Shift Shaft

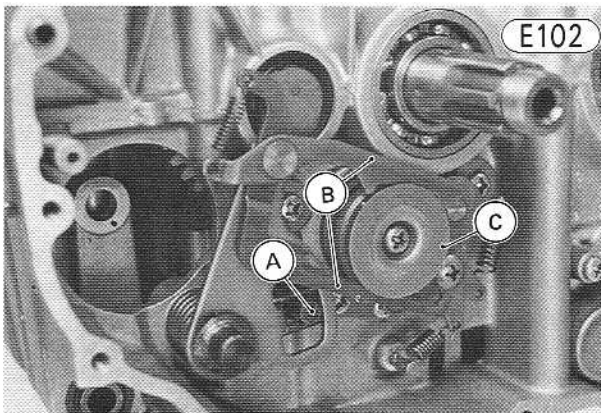

A. Pin
B. Arms
C. Shift Drum

- Install the clutch (Pg. 62).
- Install the right engine cover (Pg. 62).
- Install the drive chain guard using the three screws.
- Install the engine sprocket cover (Pg. 54).
- Adjust the clutch (Pg. 20).
- Fill the engine with oil.

Disassembly—Engine Removed

Table of Contents

| | |
|-------------------------------|----|
| FLOW CHART..... | 68 |
| ENGINE REMOVAL..... | 70 |
| CRANKCASE SPLIT..... | 72 |
| TRANSMISSION..... | 83 |
| Drive Shaft Disassembly..... | 84 |
| Output Shaft Disassembly..... | 86 |

FLOW CHART
Engine Removal

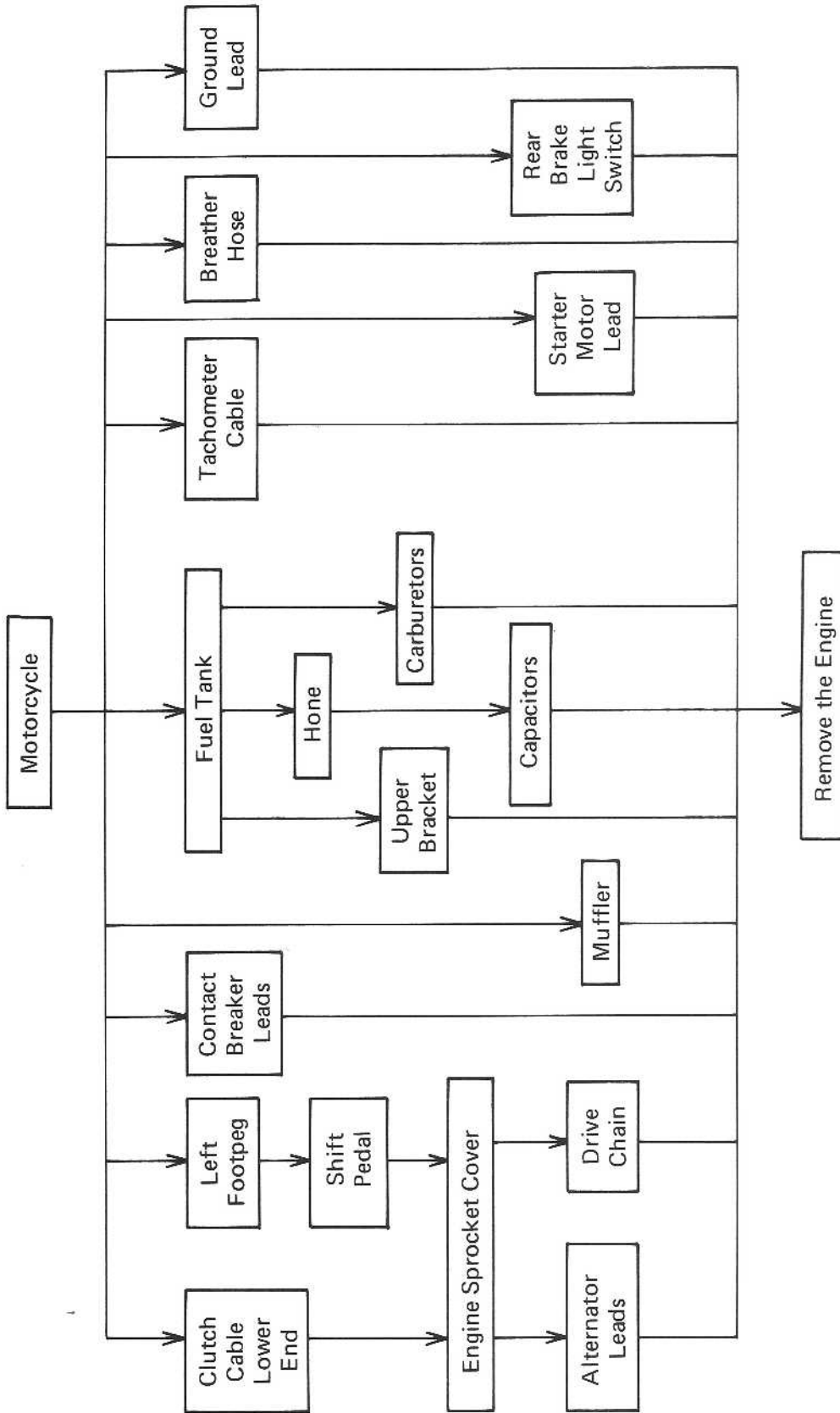

This chart is intended to be aids to proper removal. Select the component you wish to remove and follow the arrows to that point on the chart. Action with a mark ★ requires special tool for removal, installation, disassembly or assembly.

FLOW CHART
Disassembly — Engine Removed

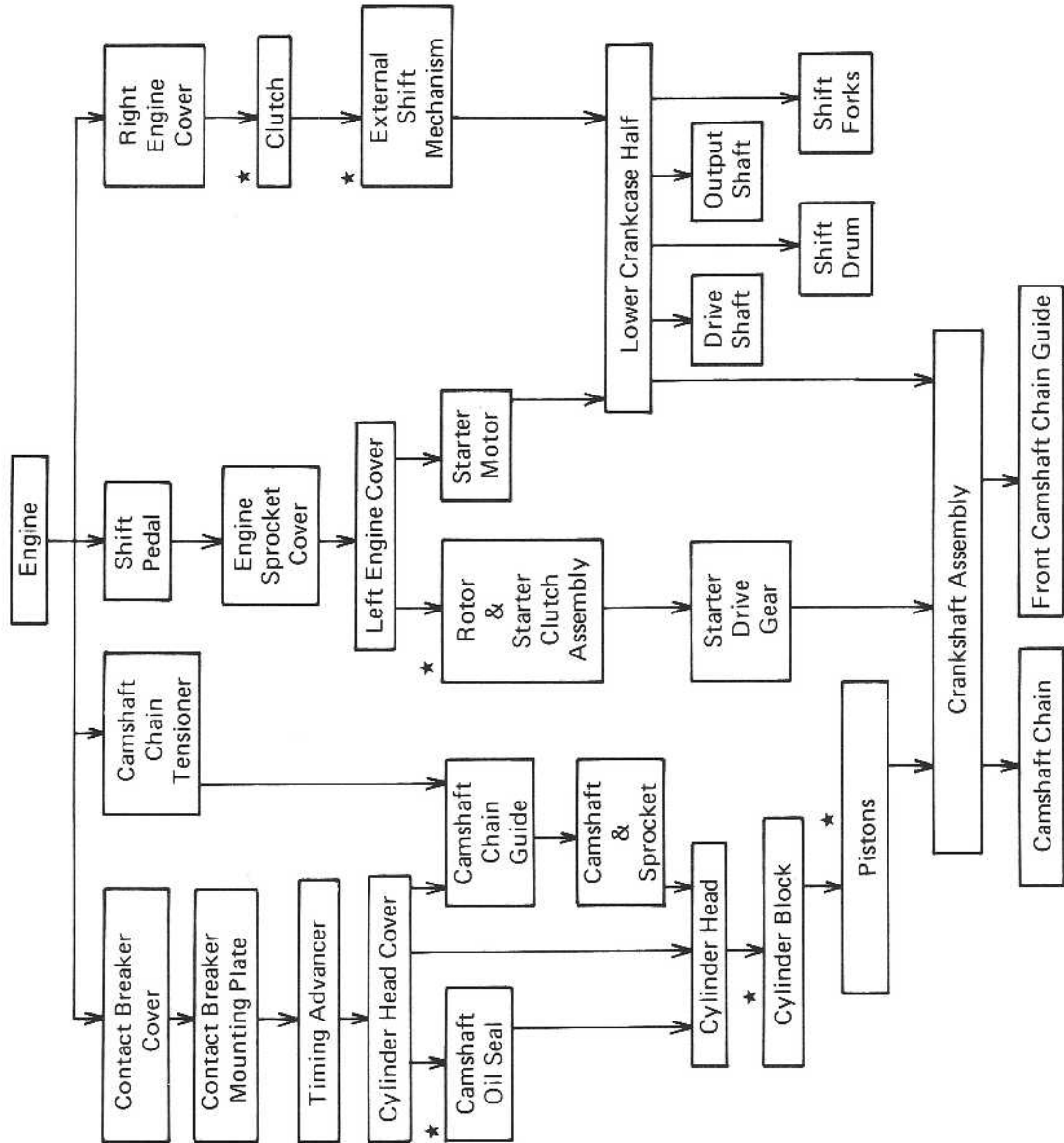

ENGINE REMOVAL

Removal:

- With the motorcycle on its center stand, place an oil pan beneath the engine, and remove the engine drain plug and oil filter to drain out the oil.

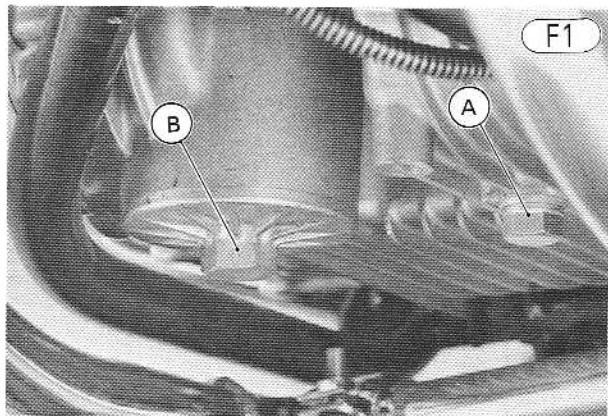

A. Drain Plug B. Oil Filter

- After draining the oil, install the drain plug and oil filter with their gaskets. Tighten the drain plug to 3.0 kg-m (22 ft-lbs) and the oil filter to 1.5 kg-m (11.0 ft-lbs) of torque.
- Remove the fuel tank (Pg. 39).
- Disconnect the spark plug leads, and remove the spark plugs.
- Disconnect the leads from the ignition coils, contact breakers, and from the capacitors.
- Disconnect the horn leads from the horn body. Remove the mounting bolts (2) and lockwashers (2), and remove the horn.
- Remove the mounting screws (2) and lockwashers (2), and remove the capacitors.

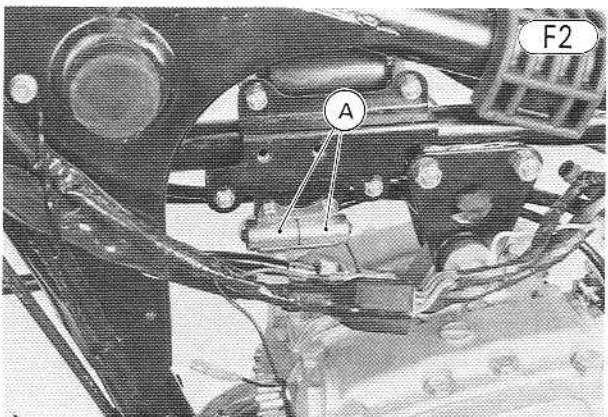

A. Capacitors

- Remove the carburetors (Pg. 39). Removal of the throttle cables from the carburetors is not necessary, but put the carburetors on the frame to avoid cable stretch or carburetor damage.
- Remove the mounting bolt and lockwasher, and take off the left footpeg.
- Remove the clamp bolt, and take off the shift pedal.
- Remove the screws (4), and pull off the engine sprocket cover.
- Remove the cotter pin, and free the clutch inner cable from the clutch release lever and sprocket cover.

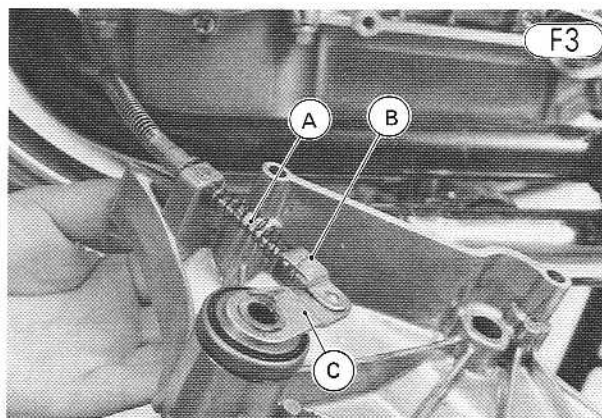

A. Inner Cable C. Release Lever
B. Cotter Pin

- Move the clutch cable out of place so that it does not get damaged during engine dismounting.
- Disconnect the alternator leads and neutral indicator switch lead.
- Remove the drive chain (Pg. 97).
- Disconnect the tachometer cable from the cylinder head cover.

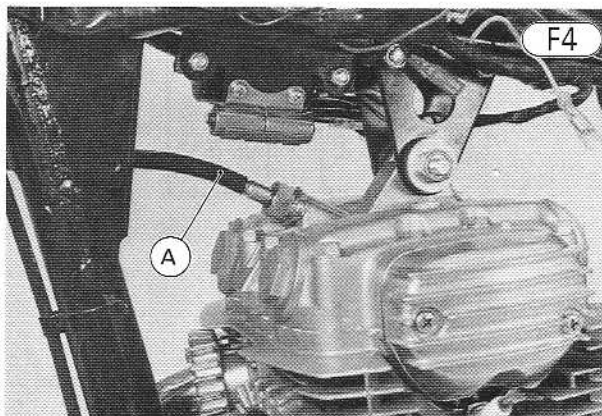

A. Tachometer Cable

- Slide the rubber boot out of place, remove the nut and lockwasher, and disconnect the lead on the starter motor terminal.
- Remove the bolt, and disconnect the ground lead on the crankcase.

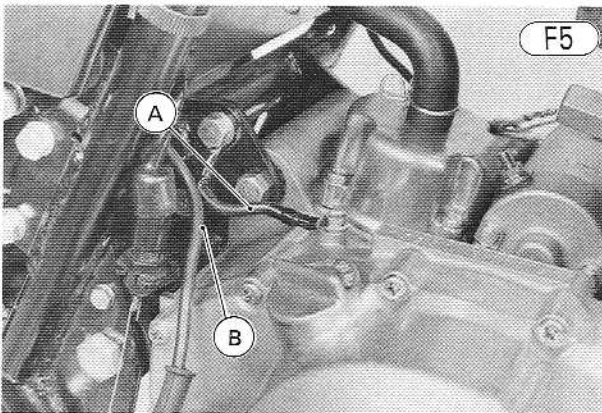

A. Ground Lead B. Starter Motor Lead

- Remove the mounting bolt, and take off the rear brake light switch and its spring.
- Remove the mounting bolt and lockwasher, and take off the right footpeg.
- Loosen the clamp on the breather hose, and pull off the hose.

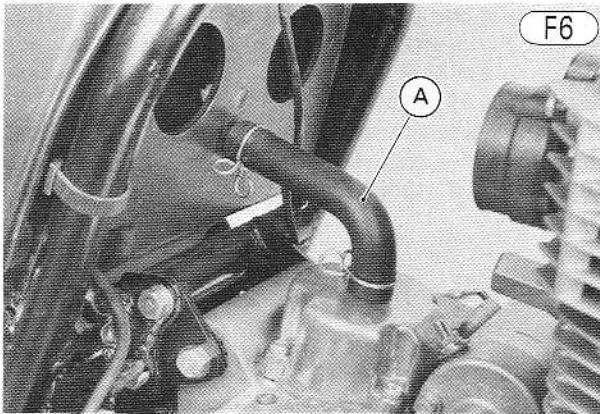

A. Breather Hose

- Remove the mufflers (Pg. 44).
- Remove the upper bracket bolts (3) and nuts (3), and take off the upper brackets.

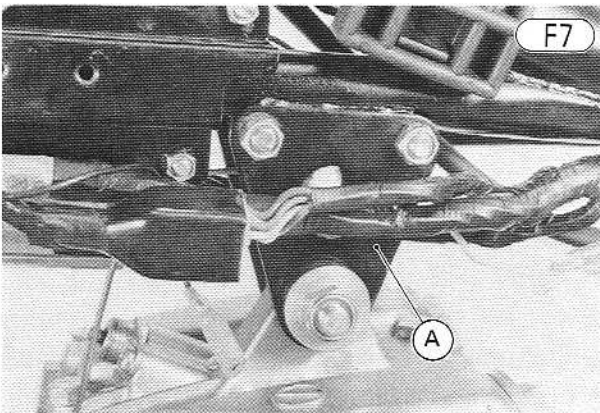

A. Upper Bracket

- Jack or lever the engine up slightly to take the weight of the engine mounting bolts.
- Remove the front bracket bolts (3) and nuts (3), and take off the front brackets.

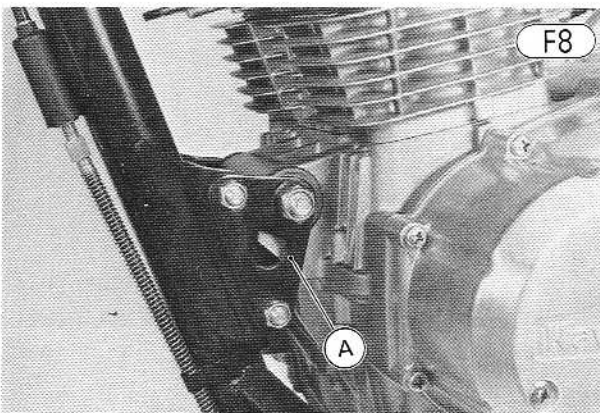

A. Front Bracket

- Remove the rear bracket bolts (2), upper engine mounting bolt and nut, and take off the rear bracket.

- Finally remove the lower engine mounting bolt and nut.

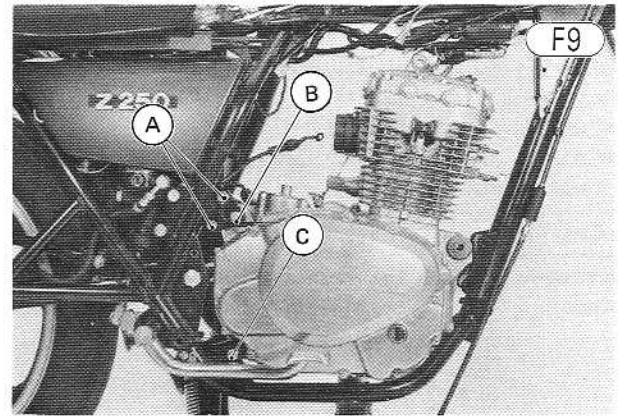

- A. Rear Bracket Bolts**
- B. Upper Engine Mounting Bolt**
- C. Lower Engine Mounting Bolt**

- Make sure that the following cables and leads are properly positioned on the engine or frame so that they will not be damaged during engine removal: starter motor lead, contact breaker lead, alternator lead, crankcase ground lead, rear brake light switch, clutch cable, and throttle cables.
- Lift up the engine until the bottom of the engine clears the frame, and move the engine out to the right.

Installation:

- Mount the engine on the frame from the right side.
- Install the front brackets, upper brackets, and rear bracket. Do not tighten the bolts yet. Place the ground lead terminal under the rear bracket bolt head.
- Lifting up the engine so that the mounting bolt threads do not get damaged, insert the four engine mounting bolts. Put on the nuts.
- Tighten the bracket bolts to 2.4 kg-m (17.5 ft-lbs) and the engine mounting bolts to 3.0 kg-m (22 ft-lbs) of torque.
- Install the mufflers (Pg. 44).
- Fit the breather hose onto the breather cover and air cleaner housing, and tighten the clamp.
- Install the right footpeg, bolt, and lockwasher.
- Insert the bolt into the crankcase with the ground lead terminal under the bolt head. Tighten the bolt.

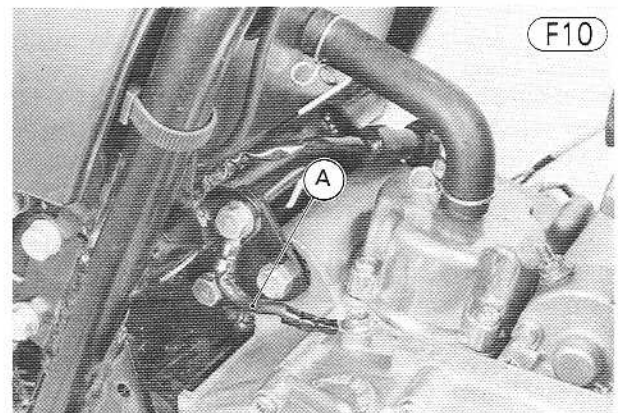

A. Ground Lead

72 DISASSEMBLY—ENGINE REMOVED

- Connect the starter motor lead to the starter motor terminal. Slide on the rubber boot.
- Install the rear brake light switch and bolt. Hook the spring onto the switch.
- Connect the tachometer cable, and tighten the cable nut using pliers.
- Install the drive chain (Pg. 97).
- Connect the alternator leads and neutral indicator switch lead.

CAUTION Push the excess slack on the leads between the drive chain guard and the crankcase so that the leads cannot contact the drive chain.

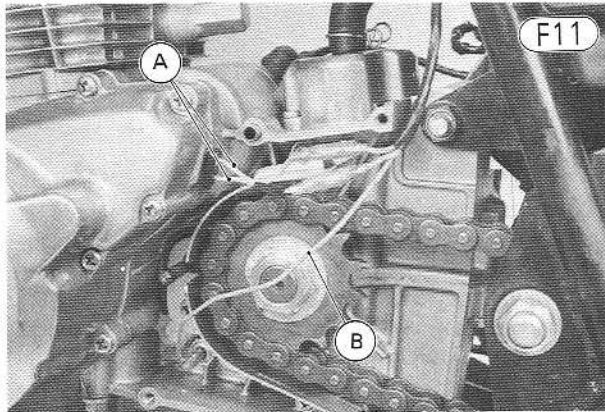

A. Alternator Leads B. Neutral Switch Lead

- Route the clutch cable between the left side of the engine and the frame. Feed the clutch cable through the engine sprocket cover and spring, and fit the tip of the inner cable into the clutch release lever.

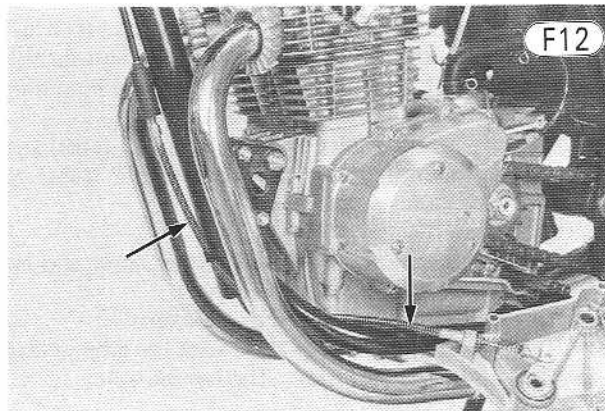

- Using a new cotter pin, secure the cable tip to the release lever.
- Check that the engine sprocket cover knock pins (2) and clutch push rod are in place, and fit the engine sprocket cover. Tighten the mounting screws.
- Install the left footpeg, bolt, and lockwasher.
- Mount the shift pedal with the front of the pedal slightly below the shaft. Insert the clamp bolt and tighten it securely.
- Install the carburetors (Pg. 39).
- Install the capacitors, mounting screws (2), and lockwashers (2). Connect the leads from the capacitors, contact breakers, and ignition coils.
- Install the horn, bolts, and lockwashers. Connect the horn leads.

- Install the fuel tank (Pg. 39).
- Fill the engine with oil.
- Adjust the clutch (Pg. 20).
- Adjust the carburetors (Pg. 18).
- Adjust the drive chain (Pg. 24).
- Adjust the rear brake (Pg. 25).
- Adjust the rear brake light switch (Pg. 26).
- Screw the spark plugs into the cylinder head, and tighten them to 2.0 kg-m (14.5 ft-lbs) of torque. Connect the spark plug leads.
- If the engine was disassembled, check the dynamic ignition timing (Pg. 15).
- Adjust the idle speed (Pg. 19).

CRANKCASE SPLIT

Disassembly:

- Remove the engine (Pg. 70).
- Remove the breather cover and gasket.
- Set the engine on a clean surface or, preferably on an engine stand (special tool).

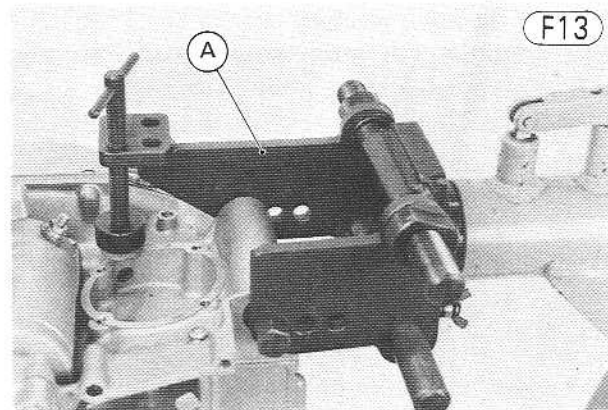

A. Engine Stand (57001-900)

- Remove the bolt and tachometer pinion holder stop. Pull out the tachometer pinion holder and pinion.

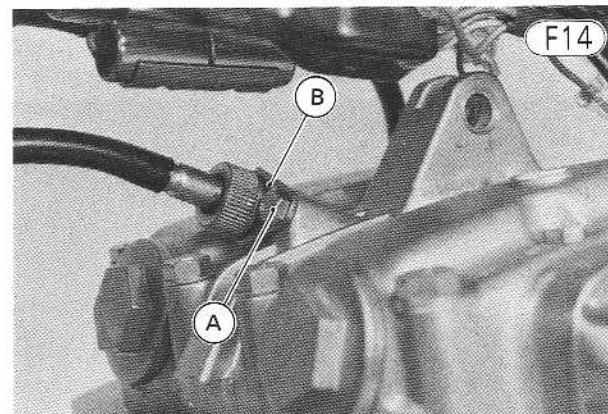

A. Bolt B. Stop

- Remove the valve adjusting caps (4).
- Remove the alternator cover.
- Remove the contact breaker cover and gasket.
- Remove the mounting screws (2), and take off the contact breaker mounting plate.

- Using a 14 mm wrench on the crankshaft to hold the camshaft steady, loosen the bolt on the camshaft. Remove the bolt, flat washer, and timing advancer.

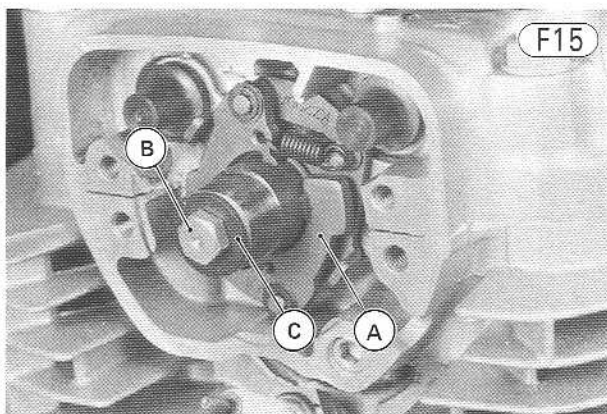

A. Timing Advancer B. Bolt C. Flat Washer

- Remove the 8 mm bolts (8) and 6 mm bolts (6) from the cylinder head cover. Remove the cylinder head cover.
- Pull the oil seal off the camshaft.
- Remove the chain tensioner cap and O ring, loosen the locknut, and remove the chain tensioner assembly from the cylinder block.

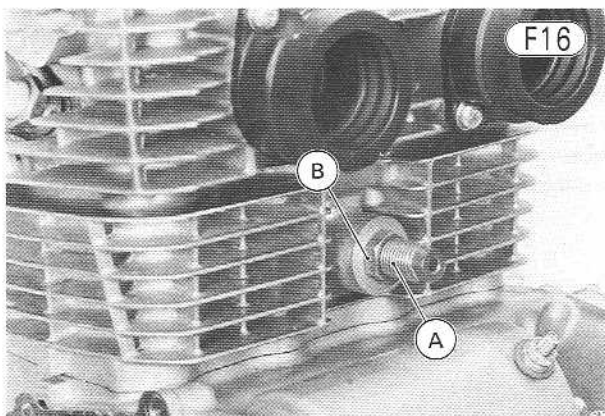

A. Chain Tensioner B. Locknut

- Pull out the camshaft chain guide from the front of the engine.

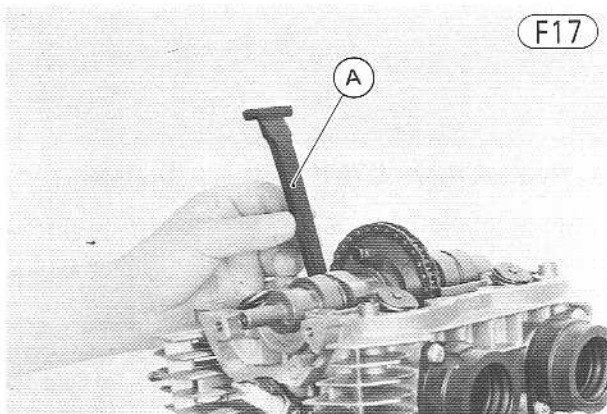

A. Camshaft Chain Guide

- Using a 14 mm wrench on the crankshaft to hold the camshaft steady, remove the camshaft sprocket bolts (2).

CAUTION Always pull the camshaft chain taut while turning the crankshaft when the camshaft chain is loose. This will prevent the lower part of the chain from snagging on the crankshaft.

- Remove the camshaft and camshaft sprocket.
- Remove the cylinder head nuts (8).
- Pull off the cylinder head. If necessary, use a slot screwdriver in the pry points provided under the cylinder head.

CAUTION Do not hammer on the screwdriver to pry off the cylinder head. Doing so may result in cylinder block damage.

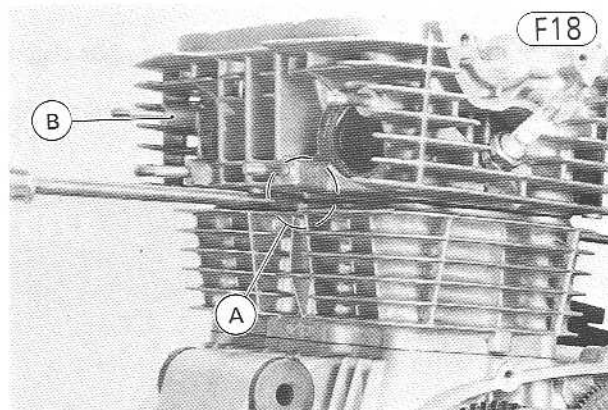

A. Pry Points B. Cylinder Head

- Remove the gasket and O rings on the cylinder block.
- Pull off the cylinder block. If necessary, use a slot screwdriver in the pry points provided on both side of the cylinder block.

CAUTION Do not hammer on the screwdriver to pry off the cylinder block. Doing so may result in cylinder block or crankcase damage.

- Remove the piston pin snap ring from the outside of each piston.

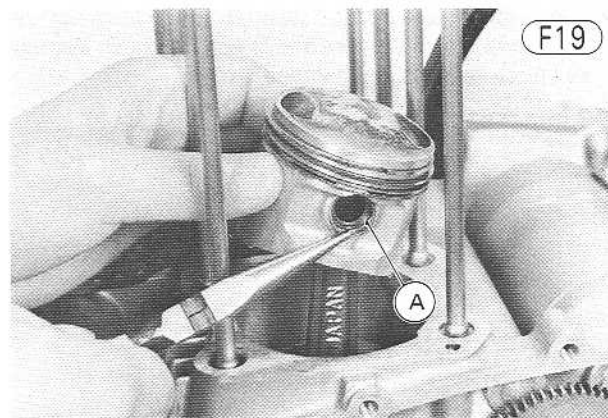

A. Snap Ring

- Remove each piston by pushing its piston pin out the side that the snap ring was removed. If necessary, use the piston pin puller and adapter "B" (special tools).

74 DISASSEMBLY—ENGINE REMOVED

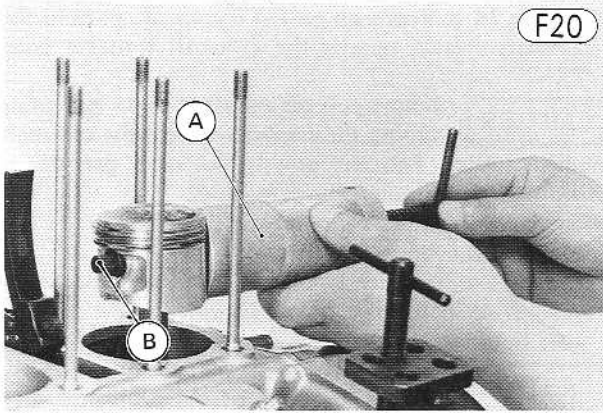

A. Piston Pin Puller (57001-910)
B. Adapter "B" (57001-913)

- Remove the screws (14), and take off the right engine cover and gasket.
- Remove the clutch spring bolts, washers, and springs (5 ea).

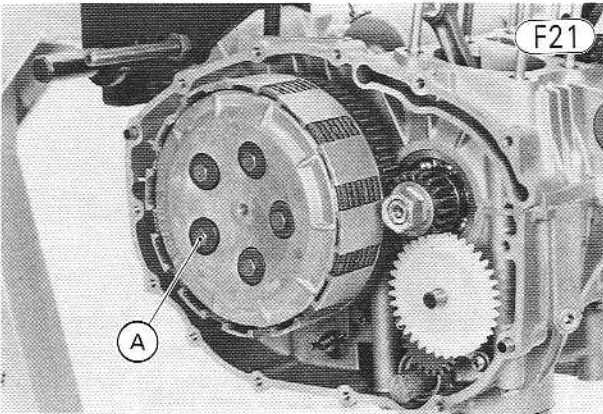

A. Clutch Spring Bolt

- Remove the spring plate and spring plate pusher.
- Remove the friction plates (7) and steel plates (6).
- Straighten the side of the toothed washer that is bent over the side of the clutch hub nut.
- Using the clutch holder (special tool) to hold the clutch hub steady, loosen the clutch hub nut. Remove the clutch hub nut and toothed washer.

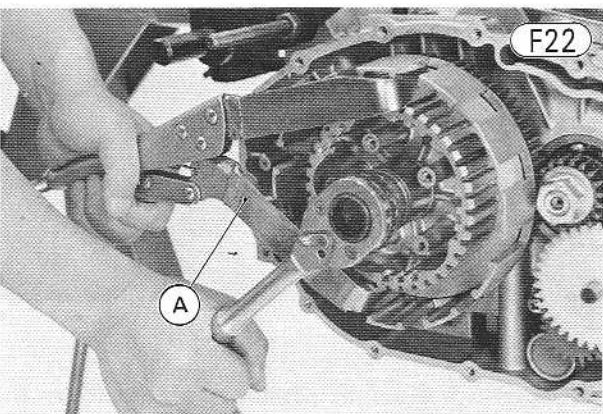

A. Clutch Holder (57001-305)

- Pull off the clutch hub, thrust washer, clutch housing, sleeve, and spacer.
- Move the shift arm and overshift limiter out of the shift drum, and pull out the external shift mechanism.

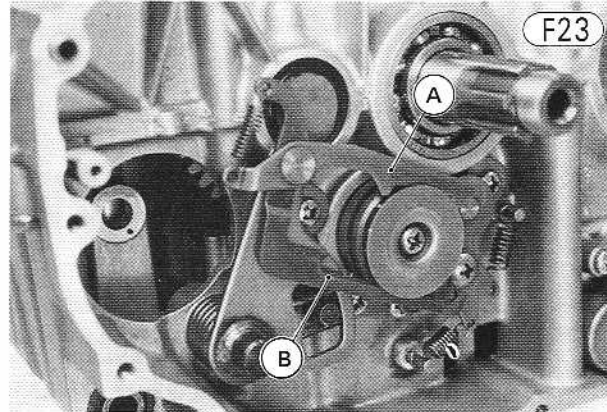

A. Shift Arm **B. Overshift Limiter**

- Remove the collar and return spring.
- Remove the screws (9), and pull off the left engine cover and gasket.
- Pull the oil pump drive gears out of place.
- Straighten the side of the toothed washer that is bent over the side of the primary gear nut.
- Using the flywheel holder (special tool) to hold the crankshaft steady, loosen the primary gear nut.

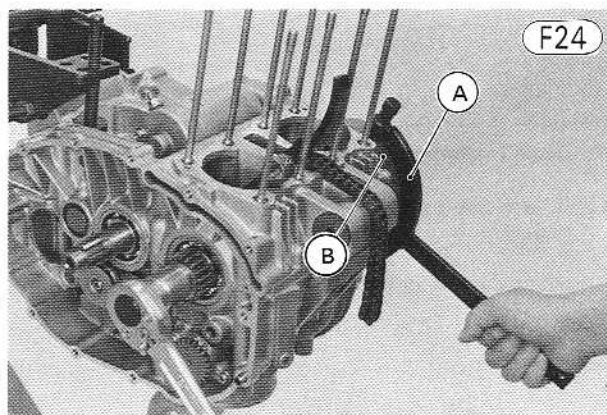

A. Flywheel Holder (57001-308) **B. Rotor**

- Remove the nut, toothed washer, and primary gear. Then remove the woodruff key on the crankshaft.
- Using the flywheel holder (special tool) to hold the crankshaft steady, loosen the bolt on the crankshaft. Remove the bolt.

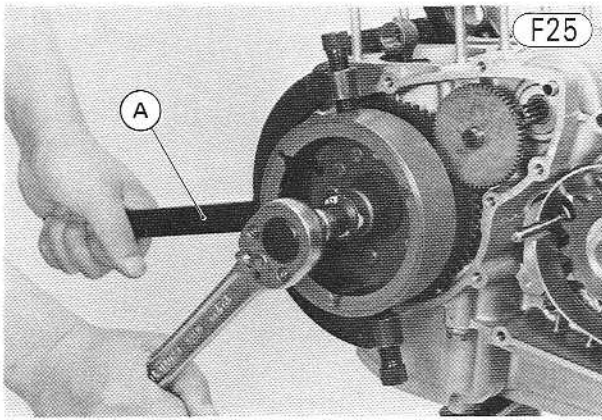

A. Flywheel Holder (57001-308)

- To pull out the rotor and starter motor clutch assembly, first insert the rotor puller adapter (special tool) into the crankshaft hole. Then pull it out using the rotor puller and flywheel holder (special tools).

CAUTION If the rotor is difficult to remove and a hammer is used to tap the rotor puller, be careful not to strike the rotor itself. Striking the rotor can cause the magnets to lose their magnetism.

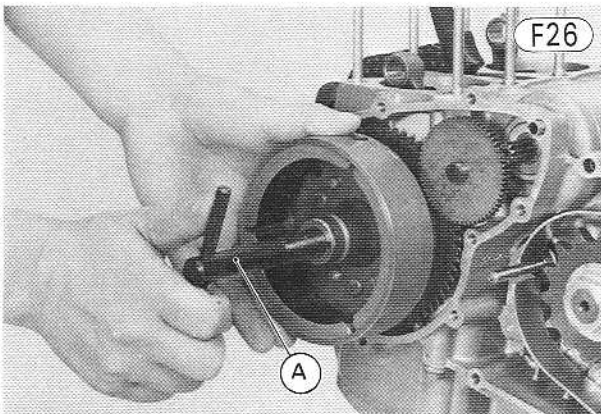

A. Rotor Puller (57001-1016) and Rotor Puller Adapter (57001-1109)

- Remove the starter idler gears, woodruff key, copper washer, and starter drive gear.

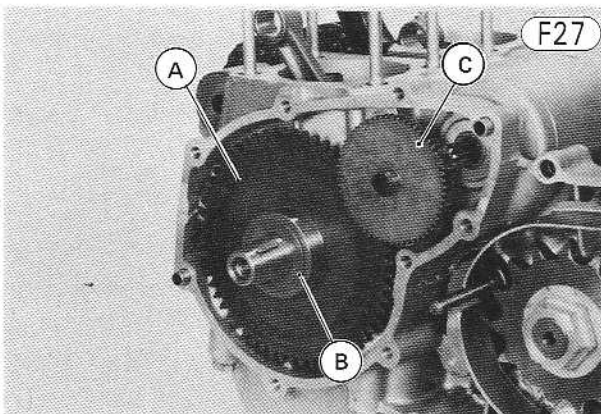

A. Starter Drive Gear
B. Copper Washer
C. Idler Gears

- Remove the starter motor mounting bolts (2).
- Pry the starter motor loose from the crankcase with a screwdriver, and slide it off.

CAUTION Do not tap on the starter motor shaft. Tapping on the shaft may damage the motor.

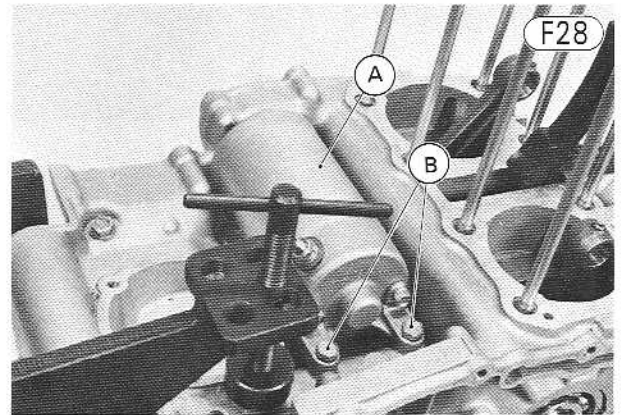

A. Starter Motor
B. Bolts

- Remove the screws (3), and take off the drive chain guard.

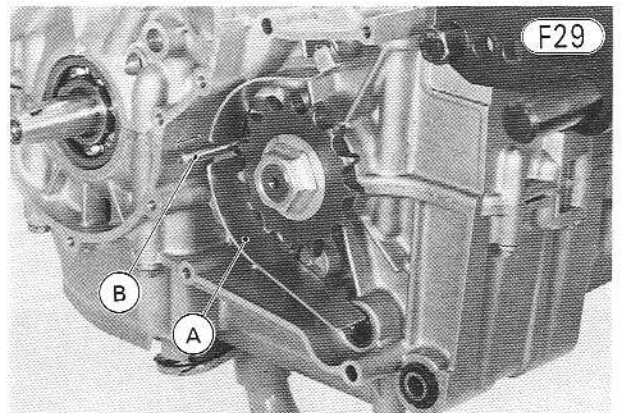

A. Drive Chain Guard
B. Push Rod

- Push out the ball, and pull out the clutch push rod from the drive shaft.
- If the output shaft is to be disassembled, remove the engine sprocket by performing the following three steps.
 - Straighten the side of the splined washer that is bent over the side of the engine sprocket nut.
 - Using the engine sprocket holder (special tool) to hold the engine sprocket steady, loosen the engine sprocket nut.

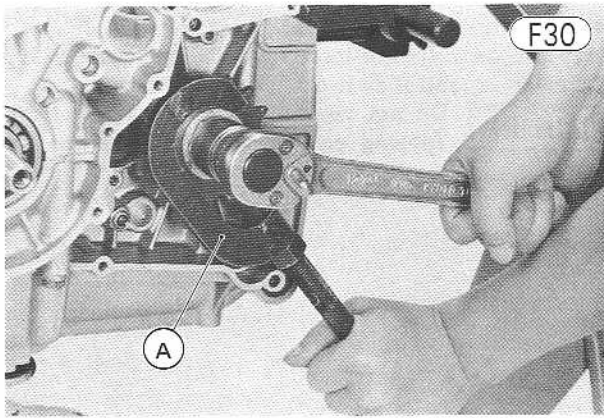

A. Engine Sprocket Holder (57001-307)

- Remove the nut, splined washer, and engine sprocket. Pull out the collar.
- Remove the 6 mm bolts (3) from the upper crankcase.

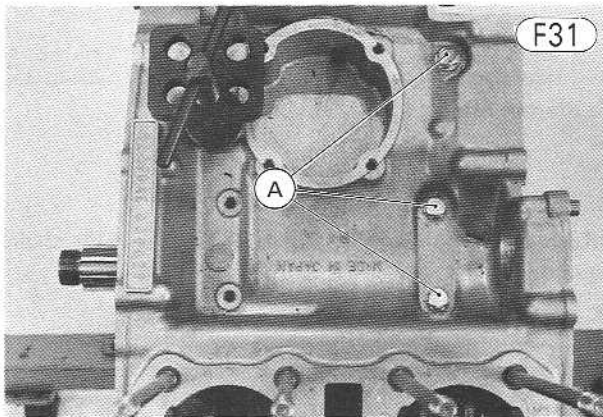

A. Bolts

- Turn the engine upside down.
- Remove the 6 mm bolts (5) and 8 mm bolts (8) from the lower crankcase.
- Split the two crankcase halves, and lift up the lower crankcase half. If necessary, use screwdrivers in the pry points (3) indicated by arrows in the photo.

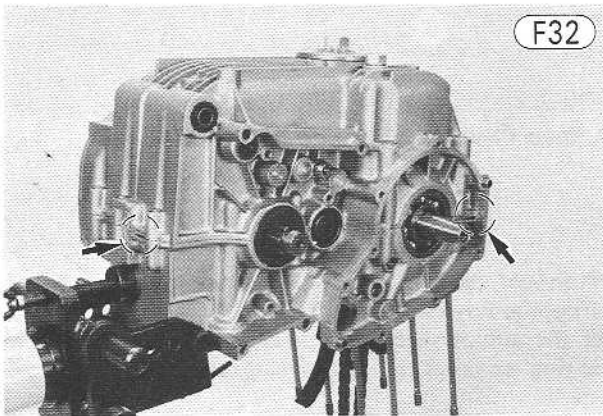

- Remove the output shaft, drive shaft, and crankshaft assemblies from the upper crankcase.

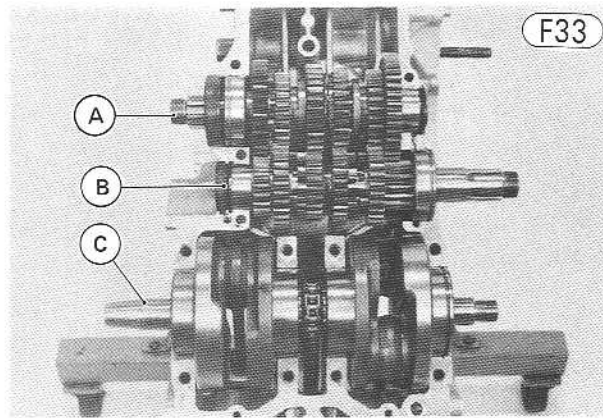

A. Output Shaft Assembly C. Crankshaft Assembly
B. Drive Shaft Assembly

- Turn or tilt the upper crankcase, then two pins will drop out and the rear camshaft chain guide should be removed.

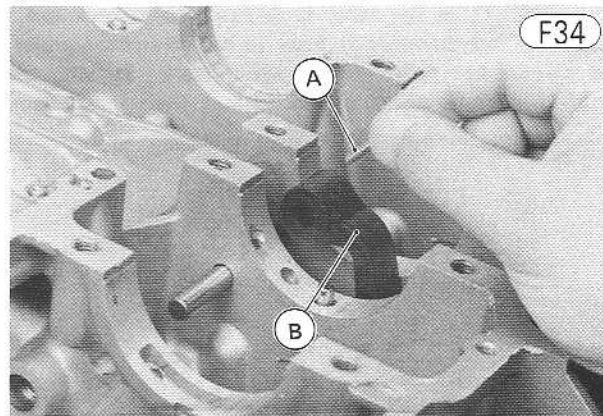

A. Small Pin B. Camshaft Chain Guide

Installation:

- Clean out the upper and lower crankcase halves thoroughly. Then, blow the oil passages in the crankcase clean with compressed air.
- Place the upper crankcase upside down, preferably on the engine stand (special tool).
- Hold the camshaft chain guide in place with its pivot pin, and insert another small pin to prevent the pivot pin from slipping out.

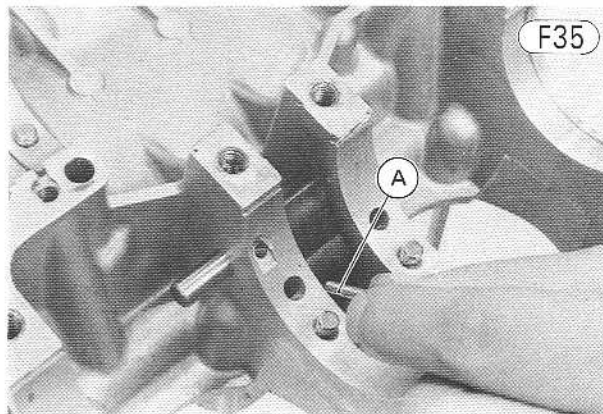

A. Small Pin

- Make sure that the bearing set pins (4), bearing inserts (3), knock pins (2), and O ring are properly placed in the upper crankcase.

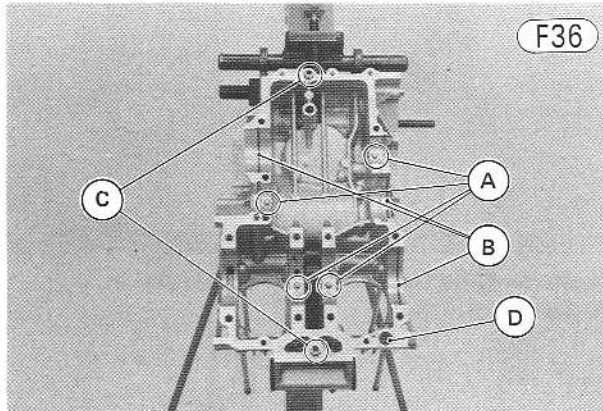

A. Set Pins C. Knock Pins
B. Bearing Inserts D. O Ring

- Apply clean engine oil to the crankshaft journals.
- Fit the camshaft chain onto the crankshaft sprocket, and put the crankshaft onto the upper crankcase so that the set pins and bearing inserts fit into the holes and groove in the crankshaft bearings.
- Put the drive shaft and output shaft assemblies onto the upper crankcase so that the set pins and bearing inserts fit into the bearing and outer race.
- Fit the O ring onto the output shaft next to the ball bearing.
- Apply a little engine oil to the transmission gears, ball bearings, needle roller bearings, shift forks, and shift drum grooves.
- Smear a thin coat of high temperature grease in the oil seals, and fit them on the drive shaft and output shaft.
- Set the transmission gears in neutral position by sliding the gears sideways.
- To set the shift drum in neutral position, turn the shift drum so that the screw on the drum contacts the neutral switch.

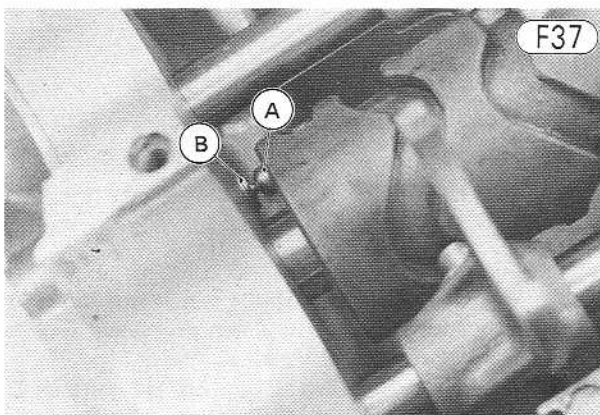

A. Screw B. Neutral Switch

- Apply liquid gasket to the mating surface of the lower crankcase. Be sure that the liquid gasket does not obstruct any oil passages.

CAUTION If the oil passage is obstructed or clogged engine or transmission seizure could result.

- Fit the lower crankcase on the upper crankcase, making sure that the shift forks fit into the grooves in the sliding gears.
- Insert the 6 mm bolts (5) and 8 mm bolts (8) into the crankcase halves. Tighten the 8 mm bolts to 2.5 kg-m (18.0 ft-lbs) and the 6 mm bolts to 1.0 kg-m (87 in-lbs) of torque. Follow the bolt tightening order shown below.

Crankcase Bolts Tightening Order

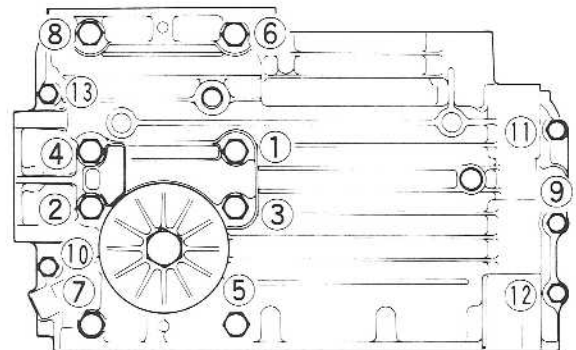

- Make sure that the crankshaft, drive shaft, and output shaft turn smoothly.
- Make sure that the transmission can be shifted smoothly, by turning the shift drum and drive shaft.

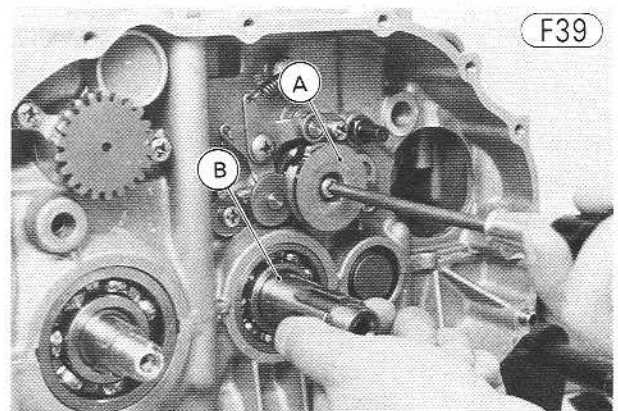

A. Shift Drum B. Drive Shaft

- Set the engine upright.
- Insert the 6 mm bolts (3) into the left side of the upper crankcase, and tighten them to 1.0 kg-m (87 in-lbs) of torque.
- Clean the starter motor lugs and crankcase where the starter motor is grounded.
- Push the starter motor back into position.

78 DISASSEMBLY—ENGINE REMOVED

- Apply a non-permanent locking agent to the starter motor mounting bolts, and tighten the bolts to 1.0 kg-m (87 in-lbs) of torque.
- Apply a small amount of molybdenum disulfide grease in the bush in the starter drive gear. Put the starter drive gear onto the crankshaft with the protruding side facing outward. Then, put on the copper washer.
- Using a high flash-point solvent, clean off any oil or dirt that may be on the crankshaft taper or rotor hub.
- Fit the woodruff key into the groove on the crankshaft.

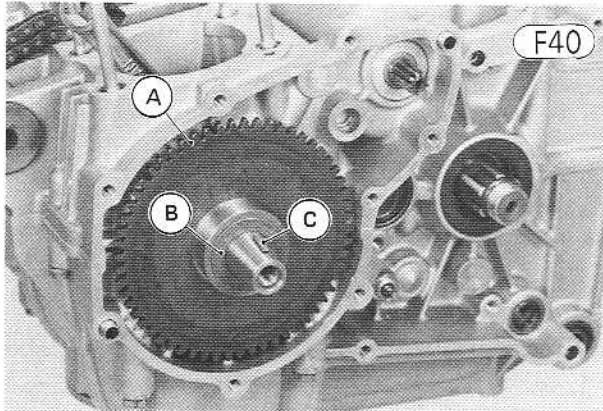

A. Starter Drive Gear
B. Copper Washer
C. Key

- Apply engine oil to the starter drive gear boss.
- Make sure that the rollers, spring caps, and springs are properly fitted in the starter clutch, and fit the rotor and starter clutch assembly on the crankshaft. Turning the starter drive gear clockwise during this procedure will help the rollers in the clutch fit properly.

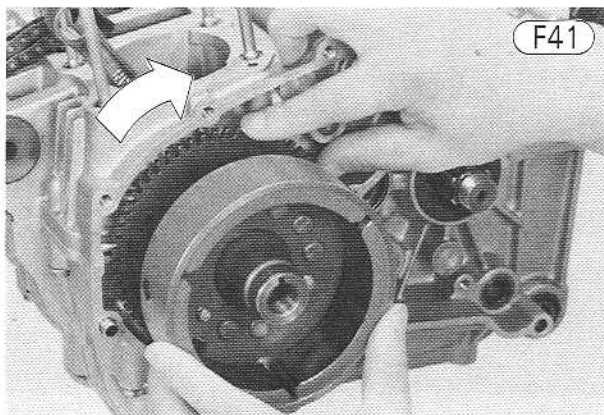

- Tighten the rotor bolt to 7.0 kg-m (51 ft-lbs) of torque, using the flywheel holder (special tool) to hold the crankshaft steady.
- Apply a small amount of molybdenum disulfide grease to the shaft portion of the starter idler gears. Fit the starter idler gears so that the gears mesh with the starter drive gear and starter pinion.

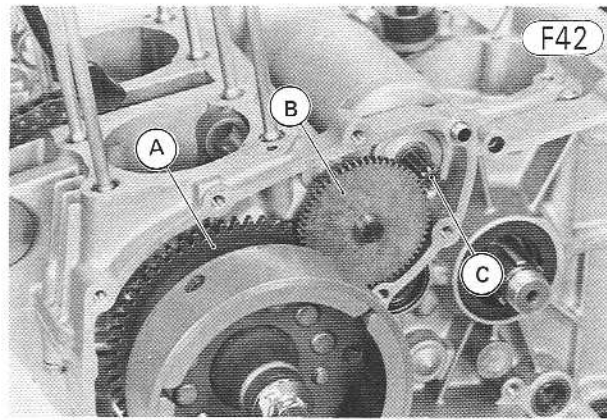

A. Starter Drive Gear
B. Starter Idler Gears
C. Starter Pinion

- Fit the woodruff key into the groove on the right side of the crankshaft.
- Fit the primary gear on the crankshaft with the protruding side facing inward.
- Put on the toothed washer with the tooth fitted into the groove in the primary gear. Screw on the primary gear nut.
- Tighten the primary gear nut to 7.0 kg-m (51 ft-lbs) of torque, using the flywheel holder (special tool) to hold the crankshaft steady.
- Bend part of the toothed washer over the side of the primary gear nut.
- Smear a small amount of molybdenum disulfide grease on the shaft portion of the oil pump drive gears. Fit the oil pump drive gears so that the gears mesh with the primary gear and oil pump gear.

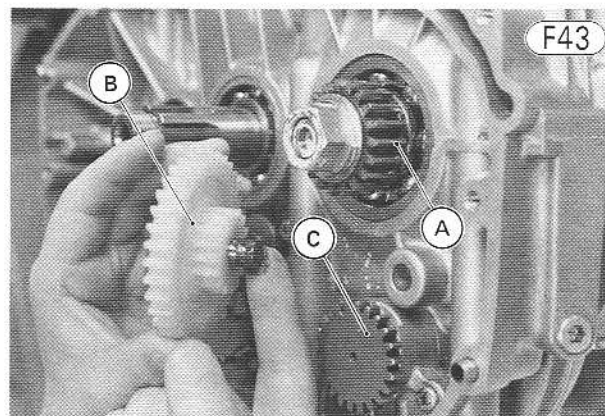

A. Primary Gear
B. Oil Pump Drive Gears
C. Oil Pump Gear

- Make sure that the return spring pin is not loose. If it is loose, remove it, apply a non-permanent locking agent to the threads, and install it.
- Fit the collar and return spring on the shift shaft. Make sure that the arm spring is installed on the two arms.

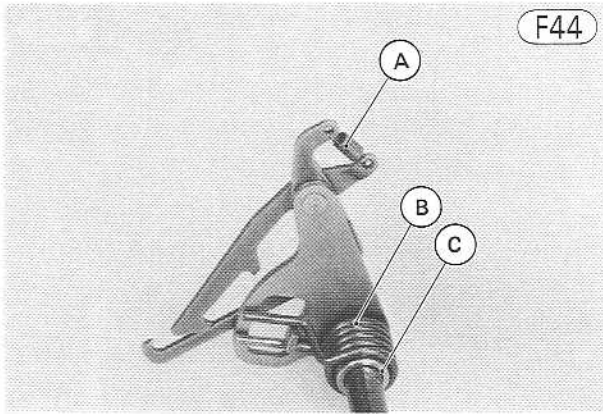

A. Arm Spring B. Return Spring C. Collar

- Fit the shift shaft oil seal guide (special tool) in the crankcase oil seal. Then install the shift mechanism with the ends of the return spring fitted on the pin and the two arms on the shift drum.

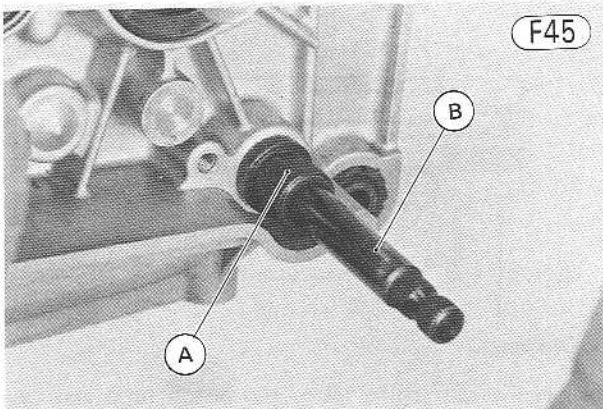

A. Oil Seal Guide (57001-264) B. Shift Shaft

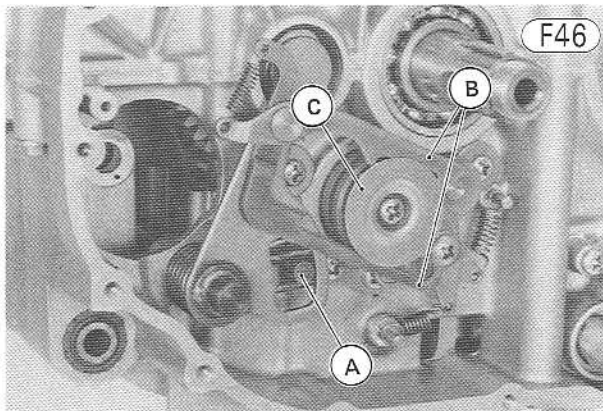

A. Pin B. Arms C. Shift Drum

- Put the spacer and sleeve on the drive shaft.
- Apply engine oil to the clutch gear and in the clutch housing hub.
- Fit the clutch housing so that the clutch housing gear meshes with the primary gear.
- Put on the thrust washer and clutch hub.

- Put on the toothed washer so that its tooth fits into the hole in the clutch hub. Screw on the clutch hub nut.

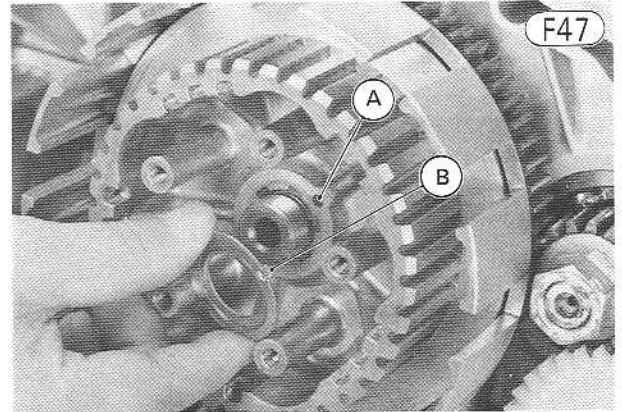

A. Hole B. Tooth

- Tighten the clutch hub nut to 12.0 kg-m (87 ft-lbs) of torque, using the clutch hub holder (special tool) to hold the clutch hub steady.
- Bend part of toothed washer over the side of the clutch hub nut.
- Fit the friction plates (7) and steel plates (6), starting with a friction plate and alternating them.

CAUTION If new dry plates are used, apply engine oil to the plates to avoid clutch plate seizure.

- Apply a small amount of molybdenum disulfide grease to the clutch steel ball and spring plate pusher, and fit them into the drive shaft.

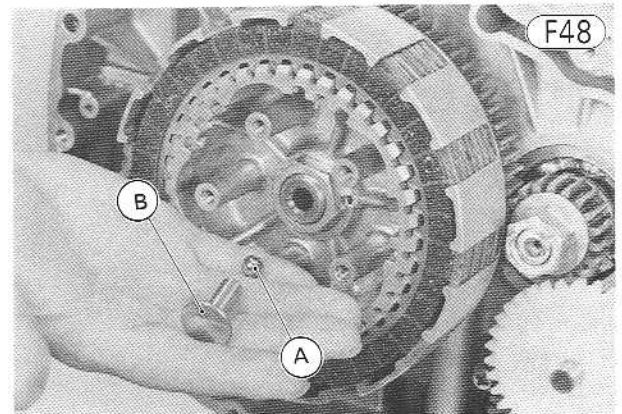

A. Steel Ball B. Spring Plate Pusher

- Install the spring plate, springs, washers, and bolts (5 ea). Crosstighten the bolts evenly to 1.0 kg-m (87 ft-lbs) of torque.
- Make sure that the two knock pins are in place, and fit a new right engine cover gasket.
- Install the right engine cover using the screws (14).
- Apply a small amount of molybdenum disulfide grease to the clutch push rod, and insert it into the drive shaft from the left side of the engine.
- Make sure that the O ring is placed on the output shaft, and put on the collar.

80 DISASSEMBLY—ENGINE REMOVED

- Fit the engine sprocket and splined washer on the output shaft, and screw on the engine sprocket nut.
- Tighten the nut to 7.0 kg-m (51 ft-lbs) of torque, using the engine sprocket holder (special tool) to hold the engine sprocket steady.
- Bend part of splined washer over the side of the nut.
- Install the drive chain guard and its screws (3).

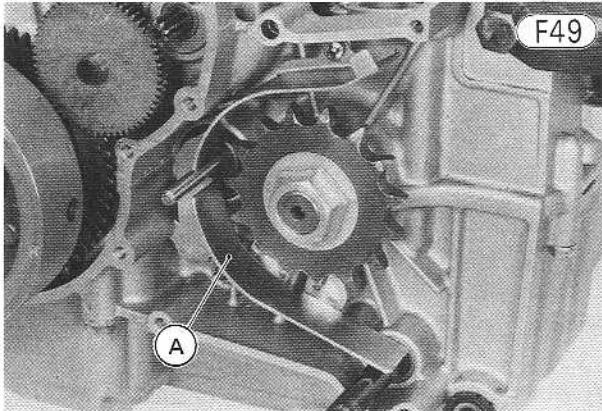

A. Drive Chain Guard

- Make sure that the two knock pins are in place, and fit a new left engine cover gasket.
- Install the left engine cover and its screws (9).
- Apply engine oil to the piston pins, and install the piston and piston pins. The arrow on the top of each piston must point toward the front of the engine.

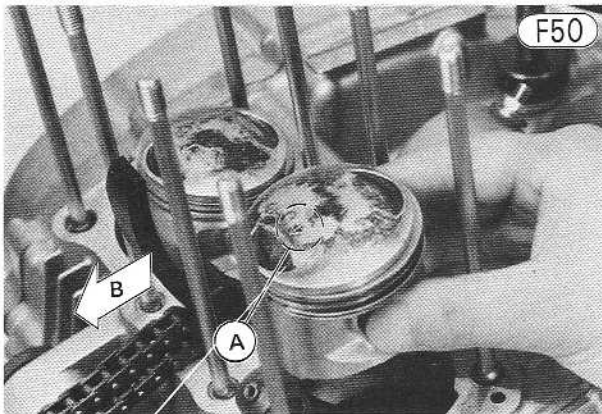

A. Arrow B. Front

- Fit a new piston pin snap ring into the side of each piston, taking care not to compress it too much. Check that the other snap rings are in place.

CAUTION Do not reuse the old snap rings. A snap ring is weakened and deformed by removal, and it may slip out and score the cylinder wall.

- Make sure that the two knock pins are properly in place, and fit a new cylinder base gasket.
- Turn the crankshaft until the height of both pistons is the same, while pulling the camshaft chain taut to prevent the chain from snagging.
- To position the pistons during cylinder block installation, use the piston holders (special tools) in the front and rear of the pistons.

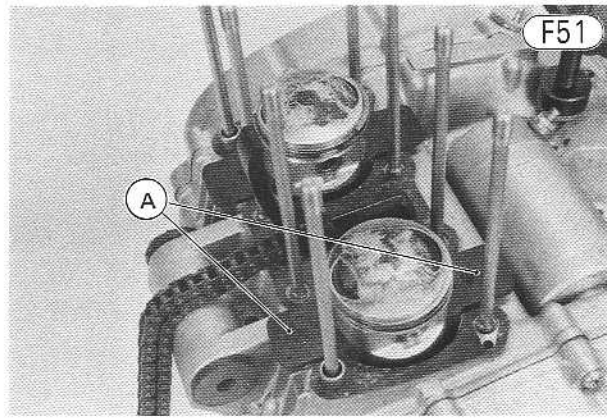

A. Piston Holders (57001-1023)

- Position each piston ring so that the opening in the top and oil ring of each piston is facing forwards, and the second ring opening faces the rear. The openings of the oil ring steel rails must be slipped to both directions about 30° from the opening of the expander.

Piston Rings

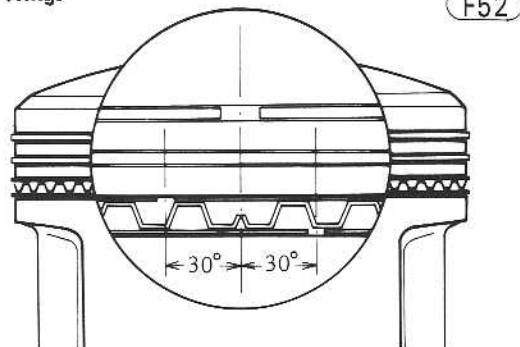

A. Openings

- Apply a clean engine oil to the piston rings and cylinder walls.
- Compress the piston rings using piston ring compressor assemblies (special tool).

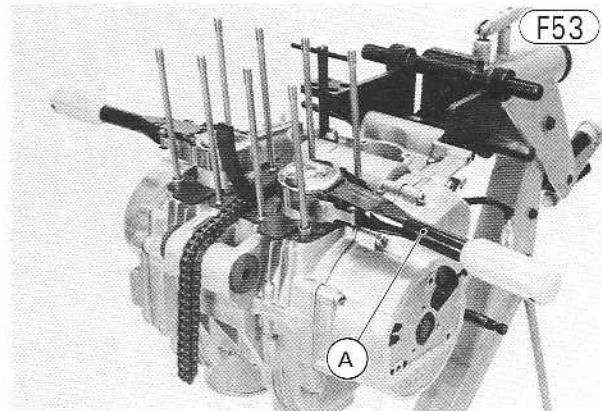

A. Piston Ring Compressor Assembly (57001-921)

- Being careful not to break the piston rings, push the cylinder block down carefully until the bottom of each cylinder clears the piston rings.
- Remove the special tools.
- Push the cylinder block down until it bottoms.
- Using compressed air, blow out any particles which may obstruct the oil passages in the cylinder head.

- Make sure that the two knock pins are properly fitted in the cylinder block.
- Put on the new cylinder head gasket with the wider bore grommets in the gasket facing up.
- Put on the O rings (2). Replace the O rings with new ones if they are deteriorated or damaged.

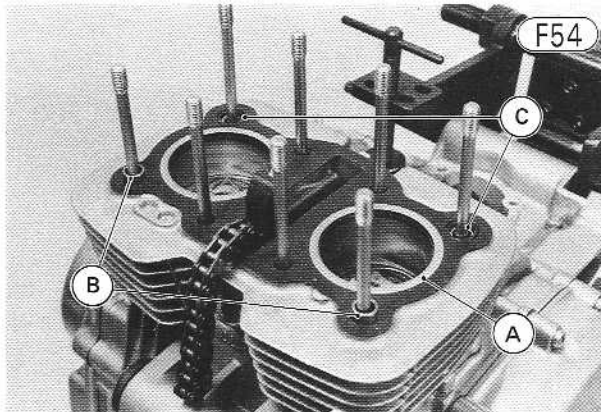

A. Bore Grommet B. Knock Pins C. O Rings

- Before installing the cylinder head, pull up the camshaft chain, and feed it through the cylinder head hole.
- Install the cylinder head. Use a screwdriver or wire to keep the chain from falling down into the cylinder block.
- Put on the cylinder head nuts (8). At first tighten the nuts to about 2.0 kg-m (14.5 ft-lbs), then tighten them to 2.5 kg-m (18.0 ft-lbs) of torque. Follow the nut tightening order embossed on the cylinder head.

Cylinder Head Nuts Tightening Order

F55

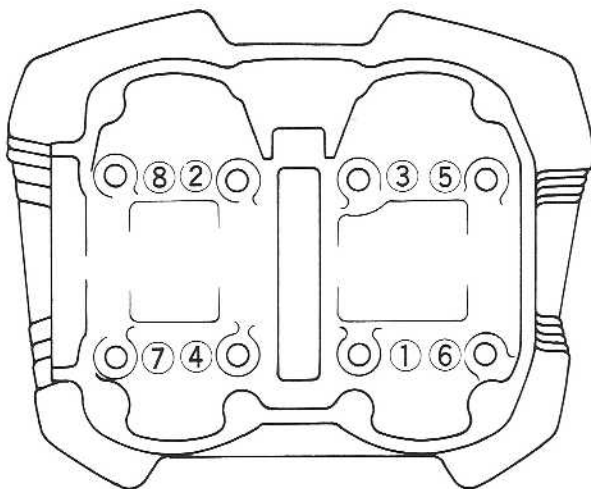

- Apply engine oil to the cam parts, tachometer gear, and cylinder head journals.
- Turn the crankshaft counterclockwise until the line (TDC mark) near the mark "1" or "L" on the rotor is aligned with the mark on the crankcase. Pull the camshaft chain taut during crankshaft rotation to prevent the chain from snagging.

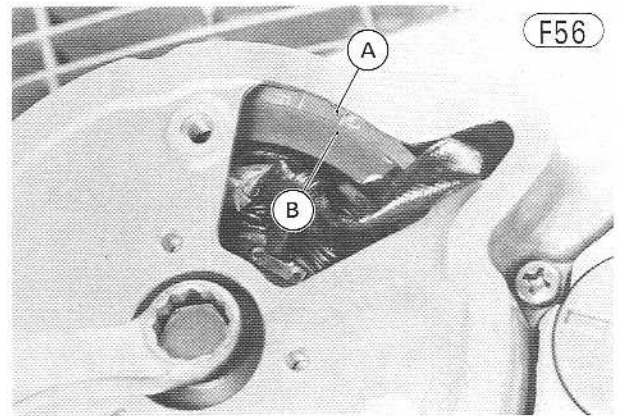

A. Timing Mark B. TDC Mark

- Feed the camshaft through the camshaft sprocket, the slender end of the camshaft first. The notched side of the sprocket should face the slender end.

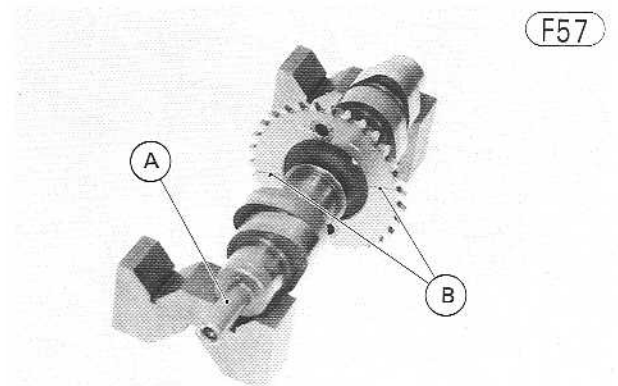

A. Slender End B. Notches

- Feed the camshaft through the camshaft chain, the slender end first, from right to left. Remove the screwdriver or wire which has been used to hold up the chain.
- Check the crankshaft position (Fig. F56), and adjust if necessary.
- Fit the camshaft chain onto the sprocket with the notches on the sprocket aligned with the cylinder head surface.

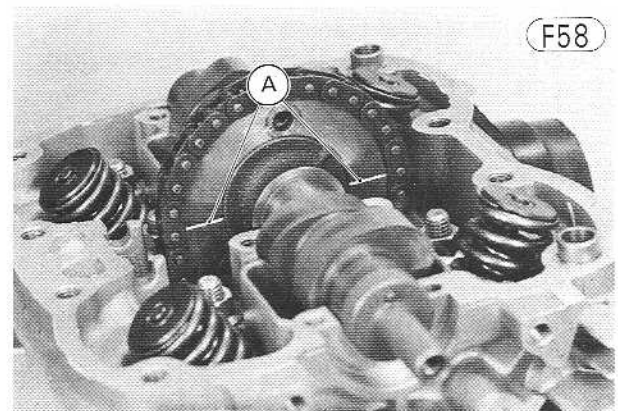

A. Notches

82 DISASSEMBLY—ENGINE REMOVED

- Turn the camshaft so that the small pin on the sprocket goes up and the mounting holes on the sprocket and camshaft are aligned.

Camshaft Chain Timing

F59

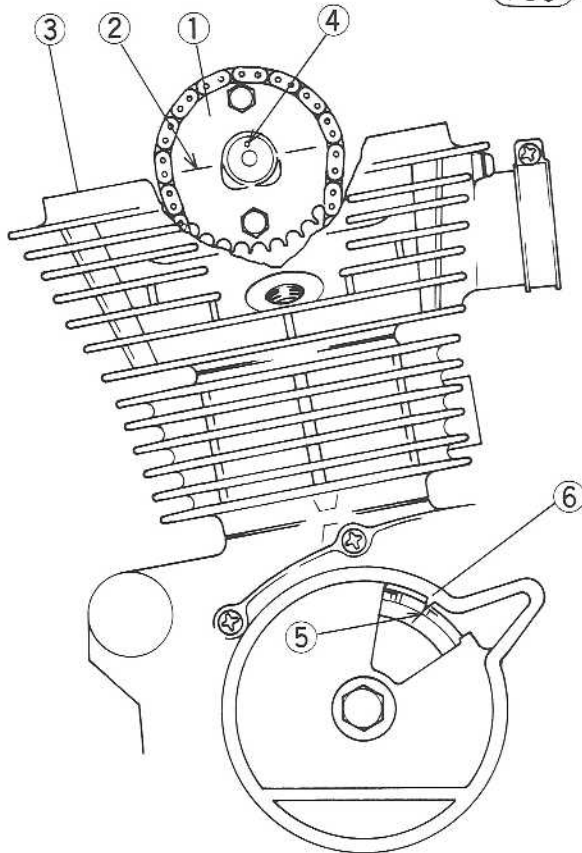

- | | |
|--------------------------|----------------|
| 1. Camshaft Sprocket | 4. Small Pin |
| 2. Notches | 5. TDC Mark |
| 3. Cylinder Head Surface | 6. Timing Mark |

- Apply a non-permanent locking agent to the camshaft sprocket bolts.
- Insert the sprocket bolt. Turn the crankshaft one turn, and insert the other sprocket bolt.
- Tighten the sprocket bolts to 1.5 kg-m (11.0 ft-lbs) of torque, using a 14 mm wrench on the crankshaft to hold the camshaft steady.
- Fit the front camshaft chain guide into the cylinder head.
- Install the chain tensioner assembly.
- Turn the crankshaft counterclockwise and check the camshaft chain timing. Correct it if necessary.
- Adjust the camshaft chain (Pg. 16), and install the camshaft chain tensioner cap and O ring.
- With a high flash-point solvent, clean off the mating surfaces of the cylinder head and cylinder head cover. Wipe it dry.
- Make sure that the tachometer pinion is removed from the cylinder head cover.

CAUTION If the cylinder head cover is installed with the tachometer pinion left in the cover, it could cause tachometer gear damage.

- Turn the crankshaft counterclockwise until no cam lobe is pointing upward. At this camshaft position, all the valves are closed, which makes cylinder head cover installation easier.

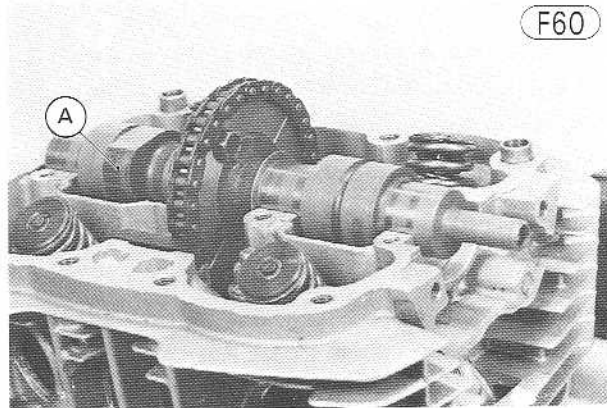

A. Cam Lobe

- Make sure that the two knock pins are properly fitted in the cylinder head.
- Apply a liquid gasket to the mating surface of the cylinder head.
- Fit the cylinder head cover, while holding up each rocker arm.
- Insert the cylinder head cover bolts, and tighten the 6 mm bolts to 1.0 kg-m (87 in-lbs) and the 8 mm bolts to 2.5 kg-m (18.0 ft-lbs) of torque. Follow the bolt tightening order embossed on the cylinder head cover.

Cylinder Head Cover Bolts Tightening Order

F61

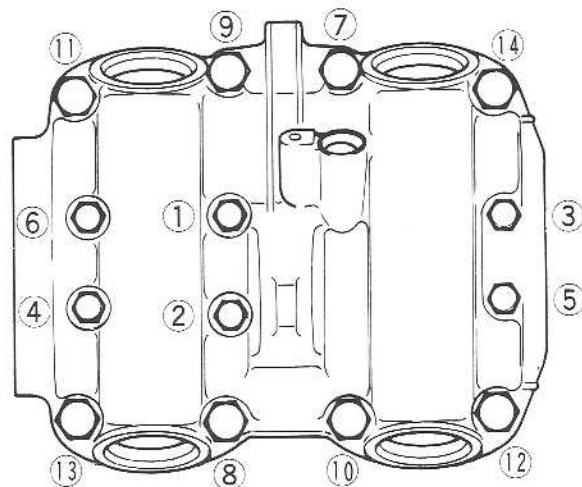

- Adjust the valve clearance (Pg. 16).
- Smear a thin coat of high temperature grease in the oil seal, and install it on the camshaft using the oil seal driver (special tool).

CAUTION If the camshaft oil seal is installed prior to the cylinder head cover installation, or if the oil seal is incorrectly installed, it could cause oil leakage or timing advancer binding.

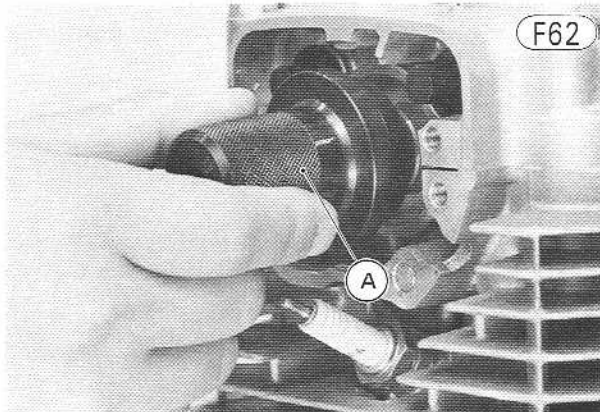

A. Oil Seal Driver (57001-1022)

- Remove the cam from the timing advancer, smear a small amount of high temperature grease in the cam, and reinstall the cam. See Assembly Note in (Pg. 62).
- Fit the timing advancer onto the camshaft, matching its notch with the pin on the camshaft.

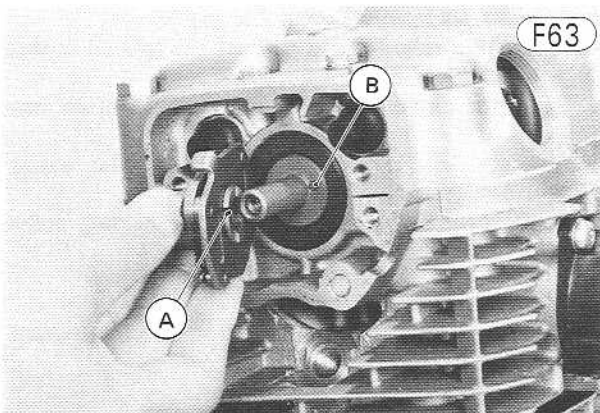

A. Notch B. Pin

- Apply a non-permanent locking agent to the timing advancer mounting bolt. Insert the bolt with flat washer, and tighten it to 0.90 kg-m (78 in-lbs) of torque.
- Install the contact breaker mounting plate, flat washers, and screws. Apply a liquid gasket around the rubber grommet and fit the grommet into place.
- Adjust the static ignition timing (Pg. 13).
- Install the contact breaker cover and gasket.
- Install the valve adjusting caps (4) and O rings.
- Install the alternator cover and screws (3).

CAUTION Before installing the screws, place the O rings under the screw heads to prevent O ring damage and resulting oil leakage.

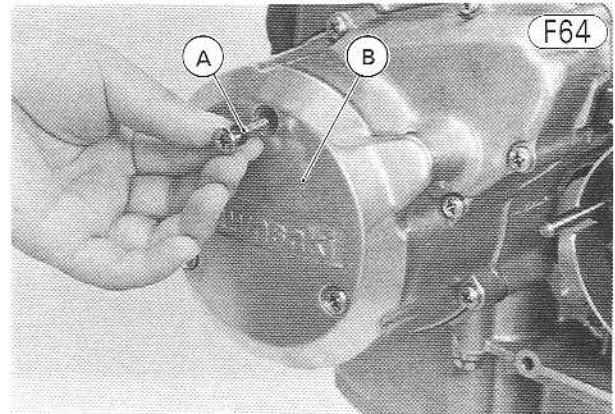

A. O Ring B. Alternator Cover

- Apply a small amount of molybdenum disulfide grease to the tachometer pinion shaft, and insert it through the pinion holder. Insert the pinion holder, and install the holder stop and bolt.

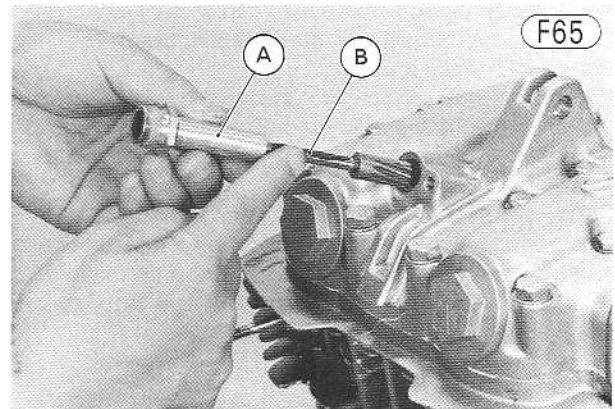

A. Pinion Holder B. Grease here.

- Install the breather cover, gasket, and screws (4).
- Install the engine on the frame (Pg. 70).

TRANSMISSION

Removal:

- Remove the engine (Pg. 70).
- Split the crankcase (Pg. 72). Removal of the following parts as explained in the crankcase split procedure is not necessary; contact breaker cover, cylinder head cover, cylinder block, pistons, rotor, and primary gear.
- Now, the drive shaft and output shaft assemblies can be separated from the upper crankcase.

84 DISASSEMBLY—ENGINE REMOVED

- Remove the screw, and remove the shift positioner, neutral finder, flat washer, and springs (2).

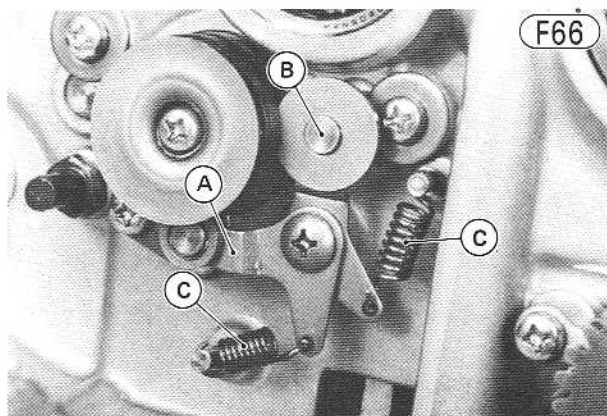

A. Shift Positioner
B. Neutral Finder
C. Spring

- Remove the screws (2) and flat washers (2). Pull out the shift rods (2), and remove the shift forks (3).
- Remove the screws (2) and shift drum guide plate, and pull out the shift drum.

Installation:

- Blow the oil passages clean with compressed air.
- Apply a small amount of molybdenum disulfide grease to the shift drum journal.
- Insert the shift drum into the crankcase. Turn the shift drum so that the screw on the shift drum contacts the neutral indicator switch. This makes the neutral finder installation easier.
- Install the shift drum guide plate and screws (2).
- Position the 3rd/4th gear shift fork so that the guide pin on the fork is aligned with the groove in the middle of the shift drum. Insert the shift rod through the fork, and install the flat washer and screw.

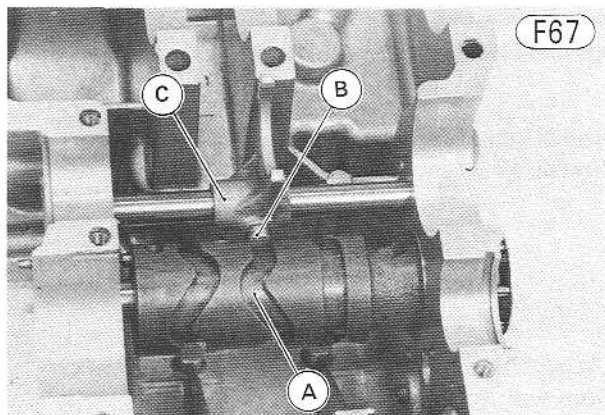

A. Groove
B. Guide Pin
C. 3rd/4th Gear Shift Fork

- Install the 5th gear and 6th gear shift forks, which are identical, with their guide pins aligned with the remaining grooves.

- Install the flat washer, shift positioner, and neutral finder using the screw, with the flat washer placed in the innermost position.
- Hook the springs (2) in the lever holes so that the opening of the spring end faces outwards (Fig. F66).
- Install the crankcase (Pg. 72).
- Install the engine.

Shift Drum Disassembly:

- Remove the screw and shift drum pin plate.
- Pull out the pins (6).
- Remove the screw which is used to contact the neutral indicator switch, if damaged.

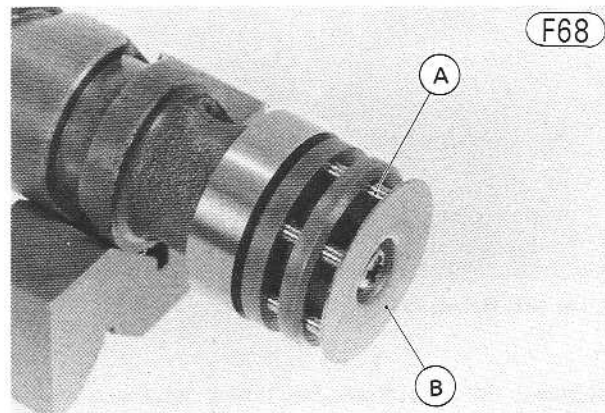

A. Pin
B. Shift Drum Pin Plate

Drive Shaft Disassembly:

- Remove the needle roller bearing outer race (1).
- Remove the circlip (2), and pull off the needle roller bearing (3), flat washer (4), and 2nd gear (5).
- Remove the circlip (6), and pull off the splined washer (7), 6th gear (8), and splined washer.
- Remove the circlip (10), and pull off the 3rd/4th gear (11).
- Remove the circlip (12), and pull off the flat washer (13) and 5th gear (14).
- Pull off the ball bearing (20) using the bearing puller and adapter (special tools).

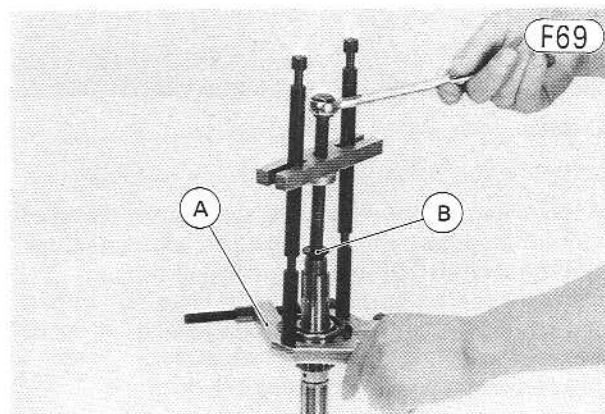

A. Bearing Puller (57001-135)
B. Adapter (57001-166)

Shift Drum, Drive Shaft, Output Shaft

F70

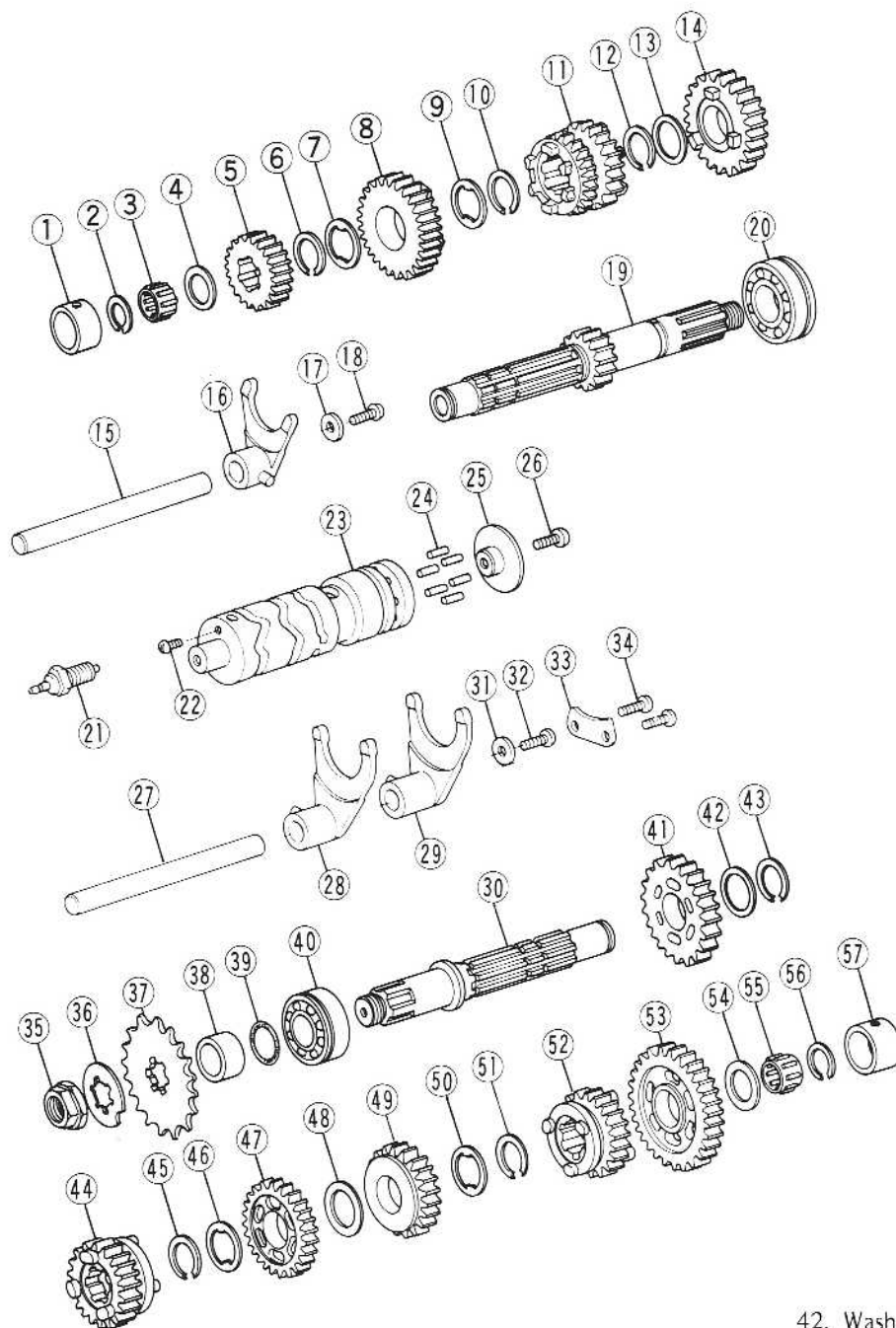

1. Bearing Outer Race
2. Circlip
3. Needle Bearing
4. Washer
5. 2nd Gear (D)
6. Circlip
7. Splined Washer
8. 6th Gear (D)
9. Splined Washer
10. Circlip
11. 3rd/4th Gear (D)
12. Circlip
13. Washer

14. 5th Gear (D)
15. Shift Rod
16. Shift Fork
17. Washer
18. Screw
19. Drive Shaft
20. Ball Bearing
21. Neutral Switch
22. Screw
23. Shift Drum
24. Shift Drum Pin
25. Shift Drum Pin Plate
26. Screw

27. Shift Rod
28. Shift Fork
29. Shift Fork
30. Output Shaft
31. Washer
32. Screw
33. Shift Drum Guide Plate
34. Screw
35. Nut
36. Toothed Washer
37. Engine Sprocket
38. Collar
39. O Ring
40. Ball Bearing
41. 2nd Gear (O)

42. Washer
43. Circlip
44. 6th Gear
45. Circlip
46. Splined Washer
47. 3rd Gear (O)
48. Washer
49. 4th Gear (O)
50. Splined Washer
51. Circlip
52. 5th Gear (O)
53. 1st Gear (O)
54. Washer
55. Needle Bearing
56. Circlip
57. Bearing Outer Race

86 DISASSEMBLY—ENGINE REMOVED

Drive Shaft Assembly Notes:

1. Using the transmission circlip driver (special tool), install the ball bearing onto the drive shaft with the mark on the bearing facing outward.
2. To install a circlip without damage, use the transmission circlip driver (special tool).

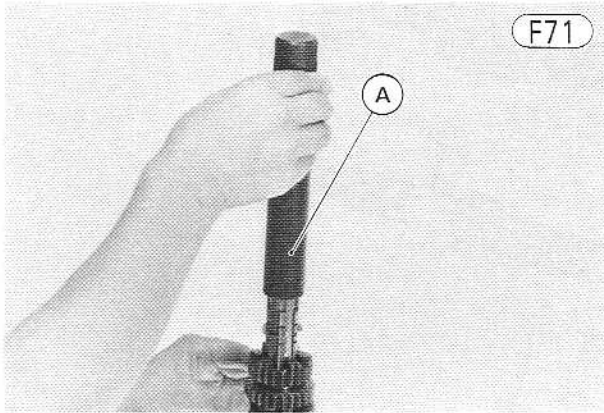

A. Transmission Circlip Driver (57001-380)

3. Replace any circlip that has been removed with new one.
4. Install the splined washer so that its teeth do not match with the circlip opening.

Circlip, Splined Washer Installation

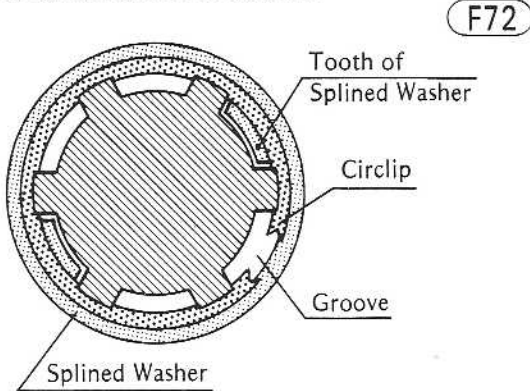

5. The drive shaft gears can be identified by size, the gear with smallest diameter being the 1st gear, and the largest one being the top gear. Be sure that all parts are put back in the correct sequence and direction, and all circlips and washers are properly in place.
6. The 2nd gear must be installed with the dented side facing outward.

Drive Shaft Gears

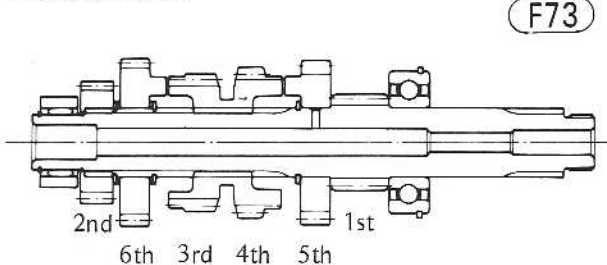

Output Shaft Disassembly:

- Pull off the needle roller bearing outer race 57.
- Remove the circlip 56, and pull off the needle roller bearing 55, flat washer 54, 1st gear 53, and 5th gear 52.
- Remove the circlip 51, and pull off the splined washer 50, 4th gear 49, flat washer 48, 3rd gear 47, and splined washer 46.
- Remove the circlip 45, and pull off the 6th gear 44.
- Remove the circlip 43, and pull off the flat washer 42 and 2nd gear 41.

Output Shaft Assembly Notes:

1. Using the transmission circlip driver (special tool), install the ball bearing onto output shaft with the mark on the bearing facing outward.
2. To install a circlip without damage, use the transmission circlip driver (special tool).
3. Replace any circlip that has been removed with new one.
4. Install the splined washer so that its teeth do not match with the circlip opening.
5. The output shaft gears can be identified by size, the gear with largest diameter being the 1st gear, and the smallest one being the top gear. Be sure that all parts are put back in the correct sequence and direction, and all circlips and washers are properly in place.

Output Shaft Gears

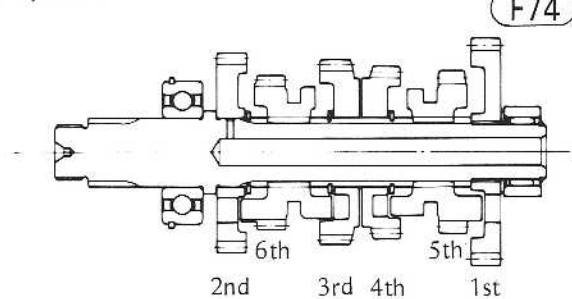

Disassembly—Chassis

Table of Contents

| | |
|---|-----|
| FLOW CHART..... | 88 |
| WHEEL, BRAKES, DRIVE CHAIN | |
| FRONT WHEEL..... | 89 |
| Speedometer Gear Housing Disassembly..... | 89 |
| Front Hub Disassembly..... | 90 |
| FRONT BRAKE..... | 92 |
| Pad Removal..... | 92 |
| Caliper Removal..... | 93 |
| Caliper Disassembly..... | 93 |
| Master Cylinder Removal..... | 95 |
| Master Cylinder Disassembly..... | 95 |
| Brake Hose Replacement..... | 96 |
| DRIVE CHAIN..... | 97 |
| REAR WHEEL..... | 97 |
| Wheel Coupling Disassembly..... | 99 |
| Rear Hub Disassembly..... | 100 |
| REAR BRAKE..... | 100 |
| Pad Removal..... | 100 |
| Rear Caliper Disassembly..... | 101 |
| Rear Master Cylinder Removal..... | 103 |
| Rear Master Cylinder Disassembly..... | 103 |
| HANDLEBAR..... | 104 |
| STEERINGS | |
| STEERING STEM..... | 106 |
| STEERING STEM BEARINGS..... | 109 |
| FRONT FORK..... | 110 |

FLOW CHART
Disassembly - Chassis

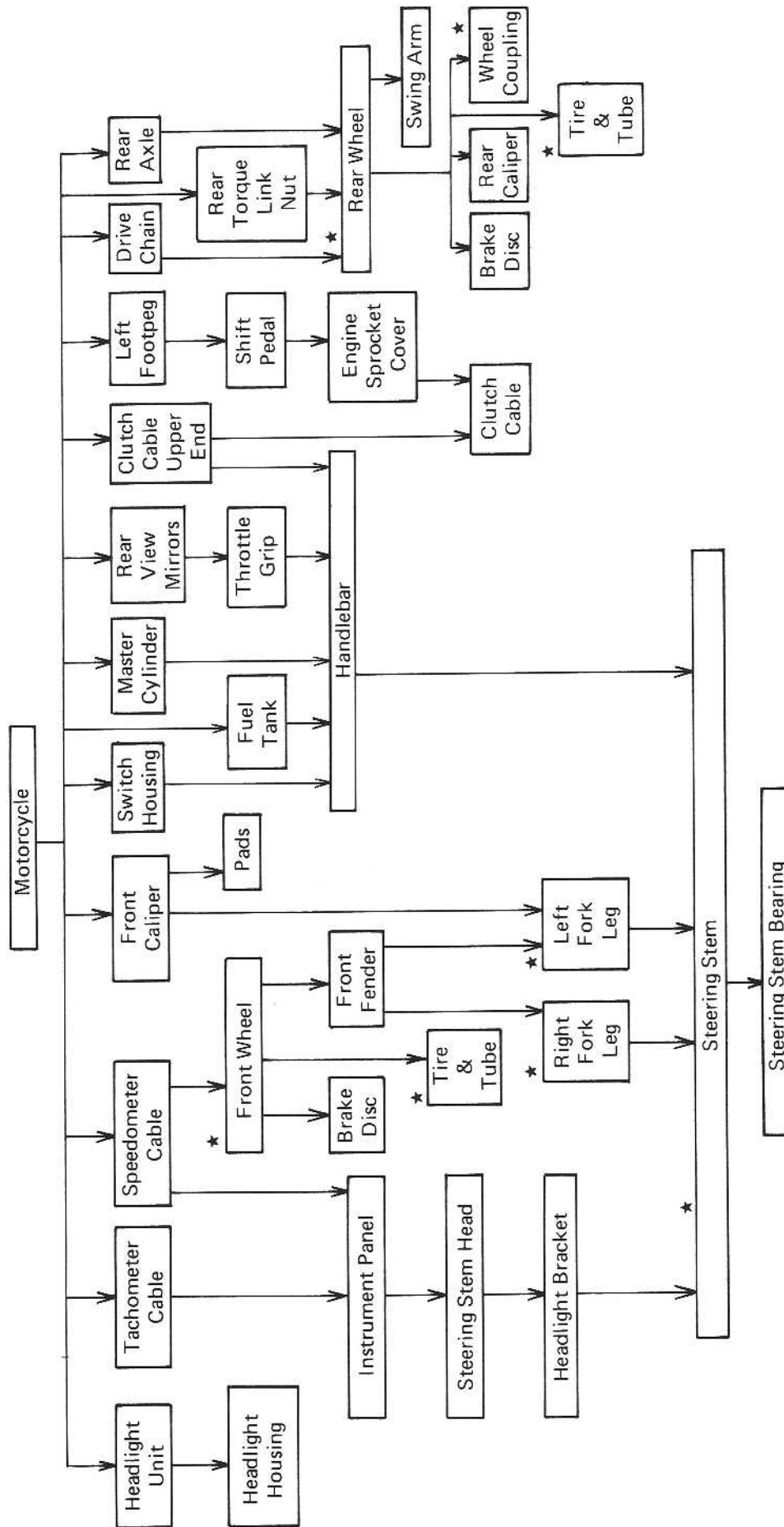

This chart is intended to be aids to proper removal. Select the component you wish to remove and follow the arrows to that point on the chart. Action with a mark * requires special tool for removal, installation, disassembly or assembly.

FRONT WHEEL**Removal:**

- Put the motorcycle up on its center stand.
- Disconnect the lower end of the speedometer cable with pliers.

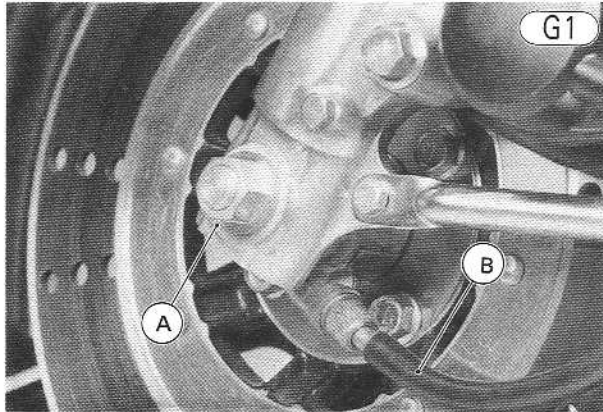

A. Axle Nut B. Speedometer Cable

- Remove the front axle nut.
- Use a jack under the engine to lift the front of the motorcycle.
- Holding the front wheel to facilitate axle removal, pull out the axle, and then remove the wheel from the motorcycle.

CAUTION Do not lay the wheel down on the brake disc. This can damage or warp the disc. Place blocks under the wheel so the disc does not touch the ground.

- Insert a wood wedge (4~5 mm thick) between the disc brake pads. This prevents the pads from being moved out of their proper position, should the brake lever be squeezed accidentally.

Installation:

- Remove the wedge from between the disc brake pads.
- Check that the speedometer gear housing is properly fitted on the front hub (See the speedometer gear housing assembly notes on Pg. 90), and check that the collar is on the right side of the hub.
- Hold the front wheel in its place between the front fork tubes, and insert the axle from the right.
- Put the axle nut on the other end but do not tighten it.
- Turn the speedometer gear housing counterclockwise until it stops. Be sure that the small projection on the gear housing does not catch on the lower part of the left tube.

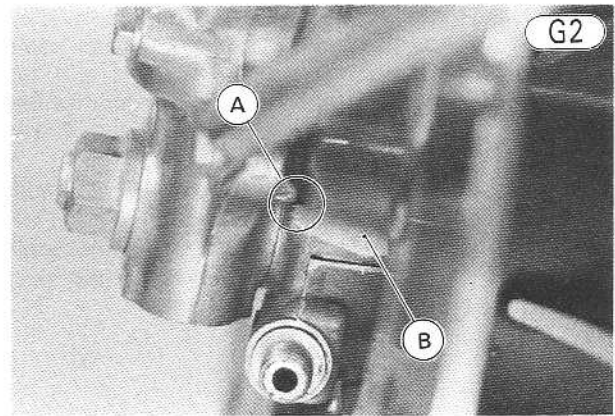

A. Projection B. Speedometer Gear Housing

- Tighten the axle nut to 6.0 kg-m (43 ft-lbs) of torque.
- WARNING** If the axle nut is not securely tightened, an unsafe riding condition could result.
- Insert the speedometer inner cable into the housing while turning the wheel so that the slot in the end of the cable will seat in the tongue of the speedometer pinion. Tighten the cable nut with pliers.
- Check the front brake for drag.

WARNING The front brake lever must be pumped to move the brake pads into operating position. If this is not done, the first few applications of the brake may be ineffective and an unsafe riding condition could result.

Speedometer Gear Housing Disassembly:

- Pull the speedometer gear housing ② off the wheel hub.
- Put the speedometer gear housing into a suitable container filled with engine oil, and heat the container so that the temperature of the oil raises to 180~200°C.
- Being careful not to suffer a burn, pick up the speedometer gear housing and remove the grease seal using a hook.

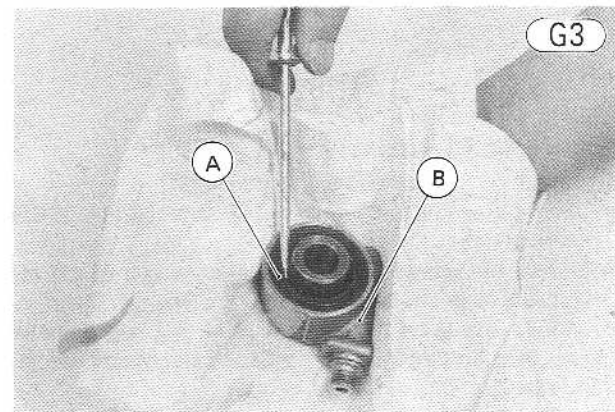

A. Grease Seal B. Gear Housing

90 DISASSEMBLY—CHASSIS

- Pull out the speedometer gear ③.
- If it is necessary to remove the speedometer cable bushing ⑩ or speedometer pinion ⑨, first drill the housing through the pin ⑥ using a 1 mm drill bit. Drill the housing from the gear side using a 2 mm drill bit.
- Using a suitable tool, tap out the pin, and then pull out the speedometer cable bushing and pinion.

NOTE: It is recommended that the speedometer gear housing is replaced as an assembly rather than repairing the components.

Assembly Notes:

1. Replace the grease seal with a new one. Apply a little grease to the seal. Install it using a suitable driver so that the face of the seal is level with the surface of the housing.
2. After inserting a new pin, punch the housing hole to secure the pin in place.
3. Regrease the speedometer gear.
4. Install the speedometer gear housing so that it fits in the speedometer gear drive notches. When properly fitted, the clearance between the speedometer gear housing and the gear drive holding plate is a little less than 3 mm.

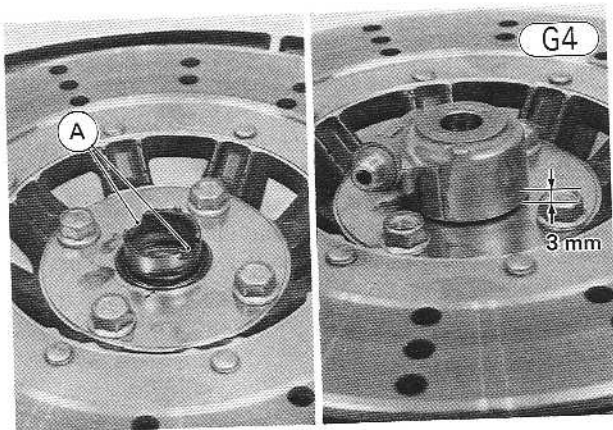

A. Notches

Front Hub Disassembly (including disc removal):

- Pull the speedometer gear housing ② and collar ③ off the front hub.
- Remove the screws ② (2), and take the cap ⑩ off the right side of the hub.
- Remove the bolts ① (4), and take the speedometer gear drive holding plate ⑫, speedometer gear drive ⑤, and disc ⑬.
- Using a hook, pull out the grease seal ⑱ and remove the circlip ⑲.

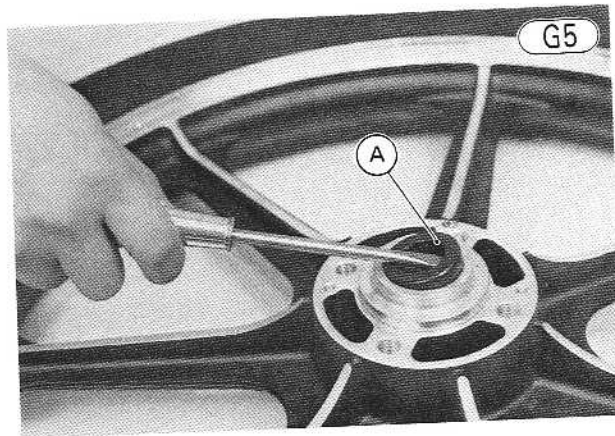

A. Grease Seal

- Insert a metal rod into the hub from the right side, and remove the bearing ⑭ on the left side by tapping evenly around the bearing inner race. The distance collar ⑮ will come out with the bearing.
- Insert a metal rod into the hub from the left side, and remove the other bearing ⑰ by tapping evenly around the bearing inner race.

Bearing Removal

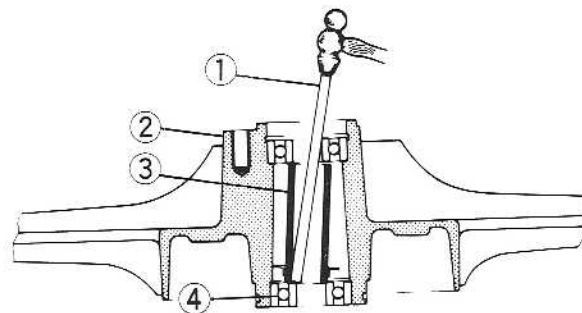

1. Metal Rod
2. Hub

3. Distance Collar
4. Ball Bearing

Front Hub Assembly:

- Lubricate the new ball bearings (Pg. 143).
 - Before installing the wheel bearings, blow any dirt or foreign particles out of the hub with compressed air.
 - Install the right side ball bearing using the wheel bearing driver and the bearing driver holder (special tools). Press the bearing until it stops at the bottom of the hole.
- NOTE:** The wheel bearing must be installed with the shielded side facing outward.

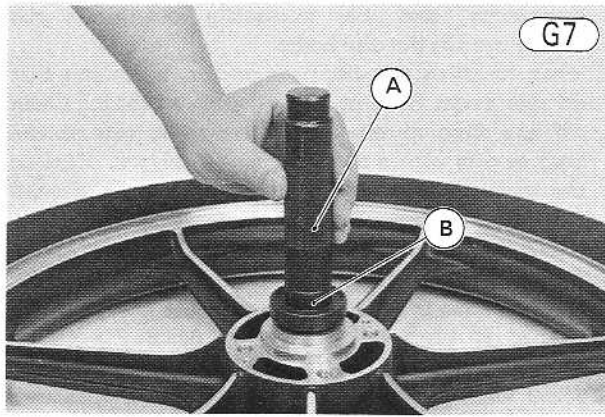

A. Bearing Driver Holder (57001-139)
B. Bearing Driver (57001-284)

●Put the distance collar into the hub. The flanged side must face the left.

●Install the left side ball bearing with the shielded side facing outward, and install the circlip with circlip pliers (special tools).

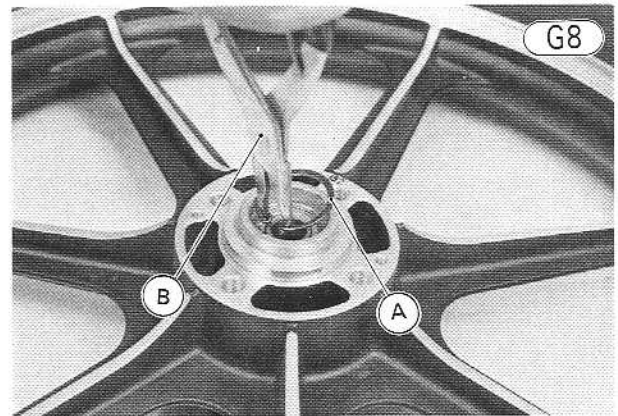

A. Circlip
B. Circlip Pliers

Front Hub

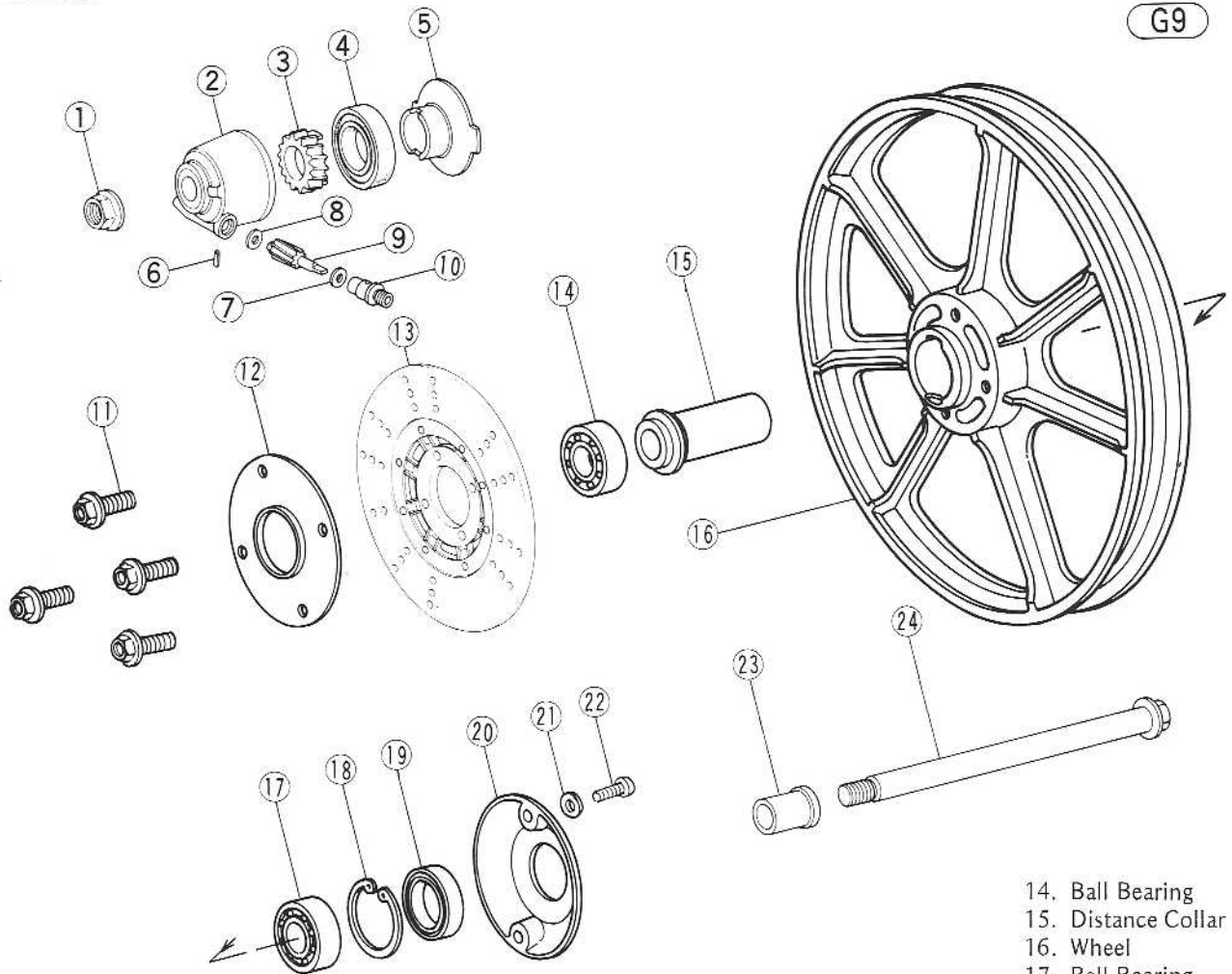

- 1. Axle Nut
- 2. Speedometer Gear Housing
- 3. Speedometer Gear
- 4. Grease Seal
- 5. Speedometer Gear Drive
- 6. Pin
- 7. Washer

- 8. Washer
- 9. Speedometer Pinion
- 10. Bushing
- 11. Bolt
- 12. Speedometer Gear Drive Holding Plate
- 13. Disc

- 14. Ball Bearing
- 15. Distance Collar
- 16. Wheel
- 17. Ball Bearing
- 18. Circlip
- 19. Grease Seal
- 20. Cap
- 21. Washer
- 22. Screw
- 23. Collar
- 24. Front Axle

92 DISASSEMBLY—CHASSIS

- Install a new grease seal using a bearing driver (special tool: PN57001-291) and bearing driver holder. Press the seal in so that the face of the seal is flush with the surface of the front hub.
- Install the cap and screws (2).
- Place the disc on the hub, and install the speedometer gear drive, fitting it in the hub notches.
- Install the speedometer gear drive holding plate with the protruding side facing out.

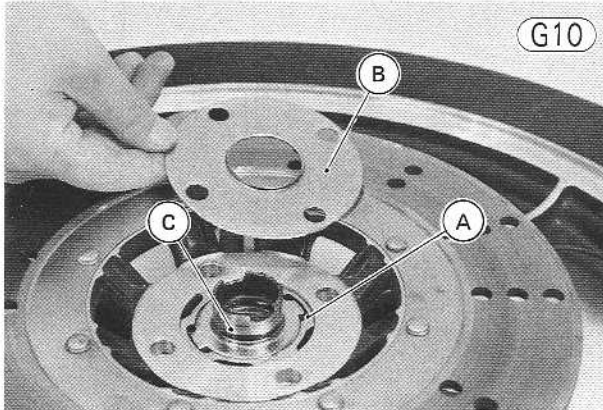

A. Hub Notches
B. Holding Plate
C. Speedometer Gear Drive

- Tighten the disc mounting bolts (4) to 3.0 kg-m (22 ft-lbs) of torque.
- After installing the disc, check the disc runout (Pg. 150).
- Install the speedometer gear housing so that it fits in the speedometer gear drive notches (Fig. G10).
- Install the collar on the right side of the hub.
- Carefully clean the disc with a high flash-point solvent. Do not use a solvent which will leave an oily residue.

FRONT BRAKE

Removal, installation, disassembly, and assembly of the front disc brake is divided as follows:

- Pad Removal
- Pad Installation
- Caliper Removal
- Caliper Installation Notes
- Caliper Disassembly
- Caliper Assembly
- Master Cylinder Removal
- Master Cylinder Installation Notes
- Master Cylinder Disassembly
- Master Cylinder Assembly Notes
- Brake Hose Replacement

NOTE: Disc removal and disc installation are covered in front hub disassembly and front hub assembly sections (Pg. 90).

Before working on the disc brake, take note of the following:

CAUTION

1. Except for the disc pads and disc; use only disc brake fluid, isopropyl alcohol, or ethyl alcohol for cleaning brake parts. Do not use any other fluid for cleaning these parts. Gasoline, motor oil, or any other petroleum distillate will cause deterioration of the rubber parts. Oil spilled on any part will be difficult to wash off

completely, and will eventually deteriorate the rubber used in the disc brake.

2. When handling the disc pads or disc, be careful that no disc brake fluid or any oil gets on them. Clean off any fluid or oil that inadvertently gets on the pads or disc with a high flash-point solvent. Replace the pads with new ones if they cannot be cleaned satisfactorily.
3. Brake fluid quickly ruins painted surfaces; any spilled fluid should be completely wiped up immediately.
4. If any of the brake line fittings or the bleed valve is opened at any time, AIR MUST BE BLED FROM THE BRAKE SYSTEM (Pg. 146).
5. When installing or assembling the disc brake, tighten the disc brake fittings to the values given in Table G1. Improper torque may cause the brake to malfunction.

Table G1 Disc Brake Torque (for Front and Rear)

| | kg-m | ft-lbs |
|-----------------------------|------|-----------|
| Brake lever pivot bolt | 0.6 | 52 in-lbs |
| Master cylinder clamp | 0.8 | 69 in-lbs |
| Fitting (banjo) bolts | 3.0 | 22 |
| Caliper holder shaft nuts | 2.6 | 19 |
| Caliper mounting bolts | 3.0 | 22 |
| Bleed valve | 0.8 | 69 in-lbs |
| Disc mounting bolts | 3.0 | 22 |
| Rear caliper Allen bolts | 3.0 | 22 |
| Master cylinder plug (rear) | 4.5 | 33 |

Pad Removal:

- Remove the caliper mounting bolts, lockwashers, and flat washers (2 ea).
- Take out the mounting screw for pad B, and remove the pad. A lockwasher and metal plate also come off.

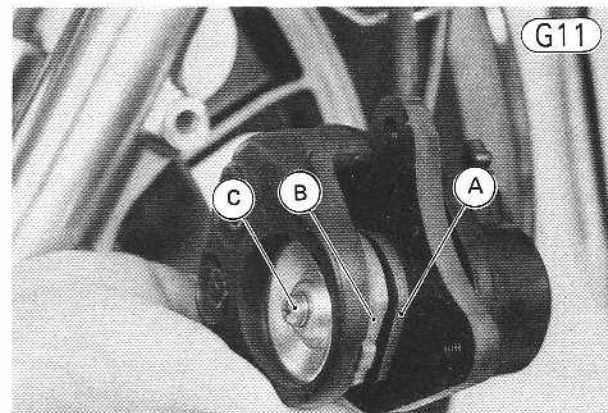

A. Pad A
B. Pad B
C. Mounting Screw

- After pad B is removed, slide the caliper holder to the piston side and remove pad A.

Pad Installation:

- Remove the bleed valve cap, open (loosen) the valve slightly, push the piston in by hand as far as it will go, and then close (tighten) the valve. Wipe up any spilled fluid, and recap the bleed valve.

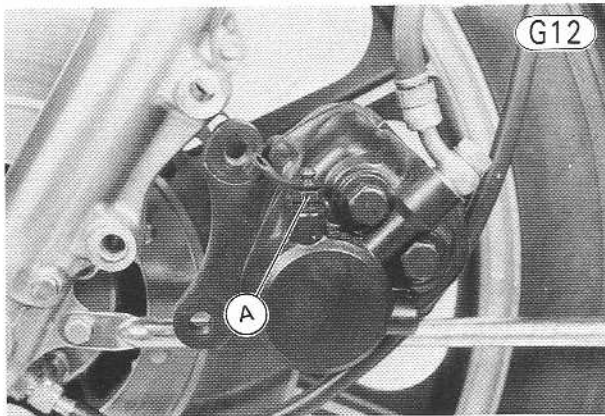

A. Bleed Valve

- Install the pad A in the caliper holder with its stepped portion facing rearward.
- Fit pad B, aligning the tongue on the pad with the groove in the caliper. Install the metal plate, lockwasher, and mounting screw; using a non-permanent locking agent on the screw.

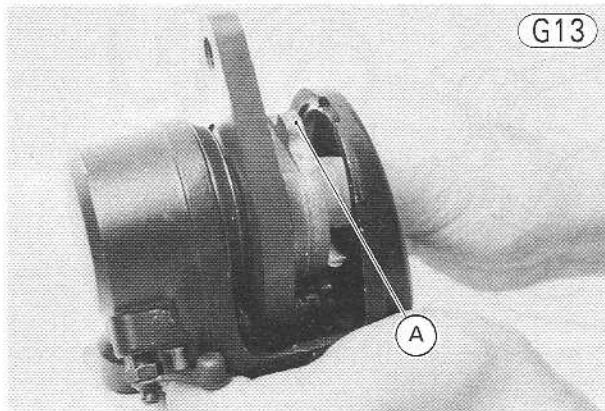

A. Tongue

- Mount the brake caliper and tighten the mounting bolts to 3.0 kg-m (22 ft-lbs) of torque.
- Since brake fluid was spilled when the bleed valve was opened, check the fluid level in the master cylinder and bleed the air from the brake system (Pg. 146).

Caliper Removal:

- If the caliper is to be disassembled, loosen the caliper holder shaft nuts (2).

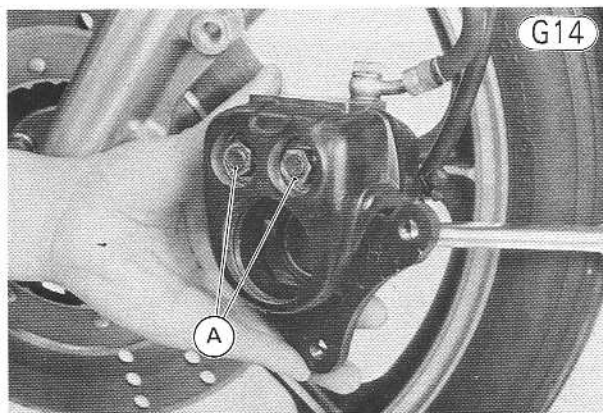

A. Shaft Nuts

- Remove the banjo bolt at the caliper, and temporarily secure the end of the brake hose as high as possible to keep fluid loss to a minimum. There is a flat washer on each side of the hose fitting.
- Remove the mounting bolts (2), each with a flat washer and lockwasher, and take off the caliper.

Caliper Installation Notes:

1. Tighten the mounting bolts to 3.0 kg-m (22 ft-lbs) of torque.
2. Tighten the caliper holder shaft nuts to 2.6 kg-m (19 ft-lbs) of torque.
3. Connect the brake hose to the caliper putting a new flat washer on each side of the brake hose fitting. Tighten the banjo bolt to 3.0 kg-m (22 ft-lbs) of torque.
4. Check the fluid level in the master cylinder, and bleed the brake line (Pg. 146).

WARNING The front brake lever must be pumped to move the brake pads into operating position. If this is not done, the first few applications of the brake may be ineffective and an unsafe riding condition could result.

Caliper Disassembly:

- Take out the mounting screw (7) for pad B (14), and remove the pad. A lockwasher (6) and metal plate (13) also come off.
- Remove the caliper holder shaft nuts (5) (2), and pull out the caliper holder shafts (1) (2) and the spacers (4) (2) taking care not to damage the dust covers (12) (4). Remove the caliper holder (17), and push out pad A (11).

CAUTION To avoid damage to the dust covers and O rings, unscrew each shaft in turn a little at a time.

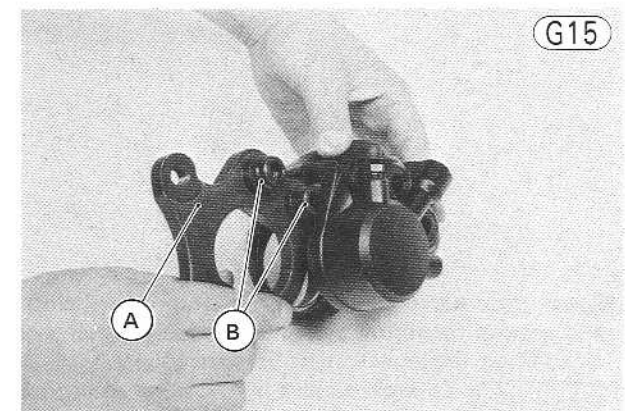

A. Caliper Holder

B. Dust Covers

- Remove the dust seal (10) around the piston (9).

94 DISASSEMBLY—CHASSIS

Front Caliper

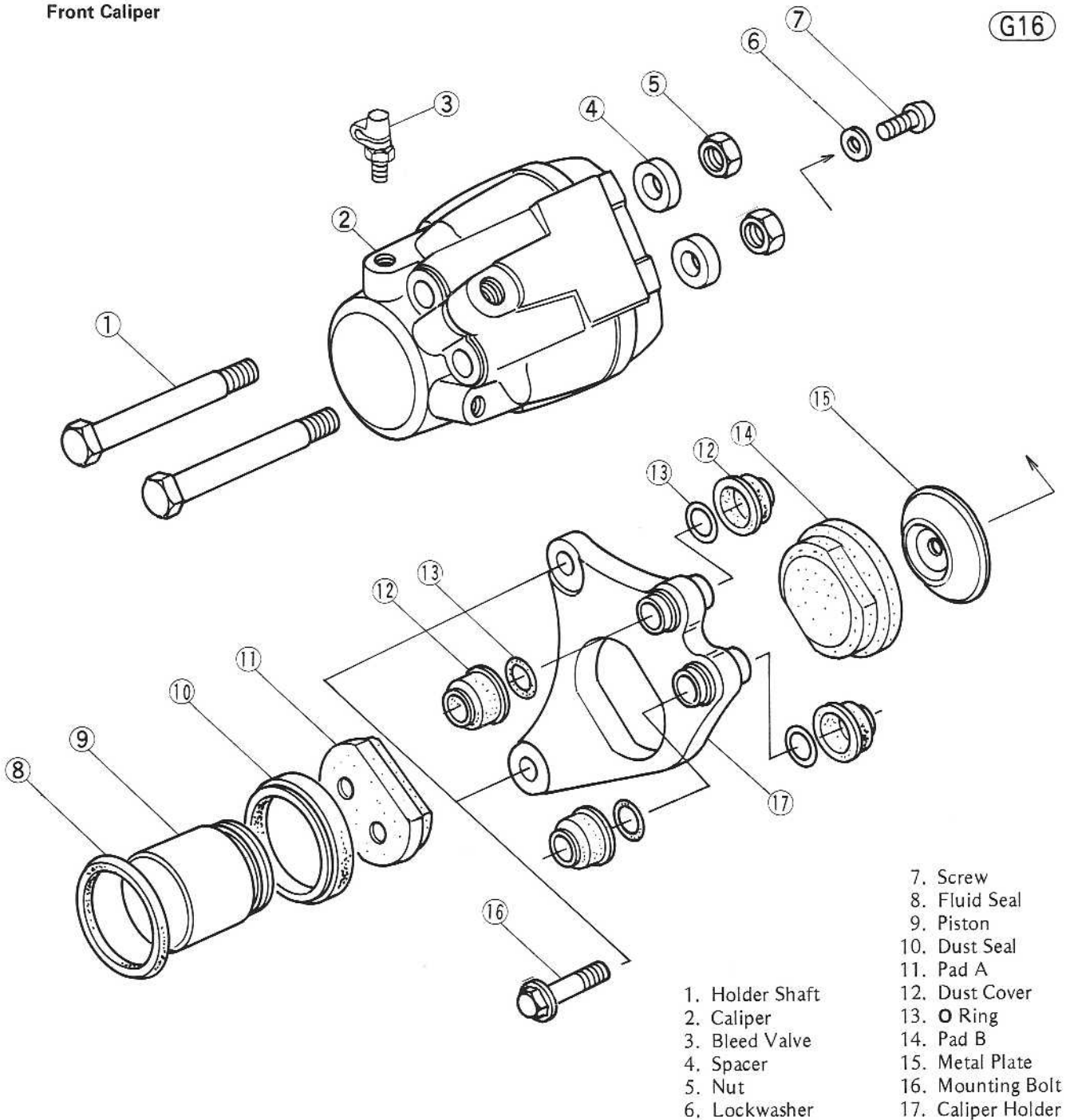

●Cover the caliper opening with a clean, heavy cloth, and remove the piston by lightly applying compressed air to where the brake line fits into the caliper.

WARNING To avoid serious injury, never place your fingers or palm inside the caliper opening. If you apply compressed air into the caliper, the piston may crush your hand or fingers.

NOTE: If compressed air is not available, reconnect the brake line and pump the piston out with the brake lever.

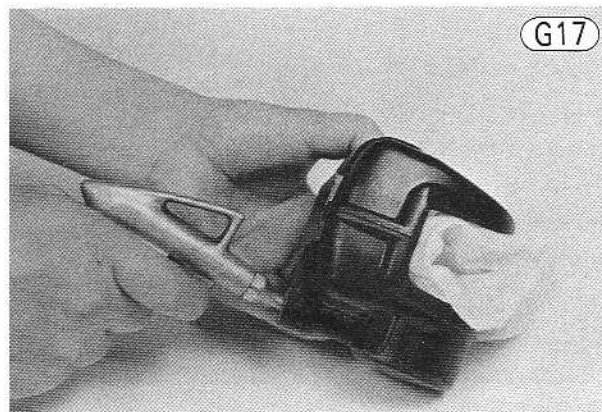

- Taking care not to damage the cylinder surface, remove the fluid seal (8) with a hook.

Caliper Assembly:

- Clean the caliper parts with brake fluid or alcohol (See CAUTION – Pg. 92).
 - Fit a new fluid seal in place inside the cylinder.
- NOTE:** It is recommended that the fluid seal, which is removed, be replaced with a new one.
- Apply brake fluid to the outside of the piston and the fluid seal, and push the piston into the cylinder by hand. Take care that neither the cylinder nor the piston skirt get scratched.
 - Install the dust seal around the dust seal stop. Check that the dust seal is properly fitted into the groove in the piston and on the dust seal stop.

Caliper Dust Seal

G18

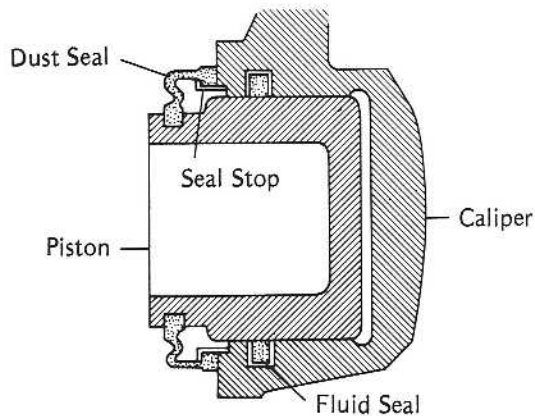

- Apply a thin coat of PBC (Poly Butyl Cuprysil) grease to the caliper holder shafts and the holder holes. (PBC grease is a special high temperature, water-resistant grease).

NOTE: Replace the dust covers and O rings if they are damaged.

- With the caliper holder properly positioned, insert the caliper holder shafts while carefully turning the shafts to prevent damage to the dust covers.
- Install the spacers and the nuts, and tighten the nuts loosely.

NOTE: Do not forget to tighten the nuts after installing the caliper on the motorcycle (Pg. 93).

- Install pad A in the caliper holder.
- Fit pad B, aligning the tongue on the pad with the groove in the caliper. Install the metal plate, lock-washer, and mounting screw using a non-permanent locking agent on the screw (Pg. 93).

Master Cylinder Removal:

- Take off the right rear view mirror.
- Using a thin-bladed screwdriver or some other suitable tool, press in the front brake switch tab which catches

in the hole in the underside of the brake lever holder, and then remove the switch.

- Pull back the dust cover, and remove the banjo bolt to disconnect the upper brake hose from the master cylinder. There is a flat washer on each side of the hose fitting.

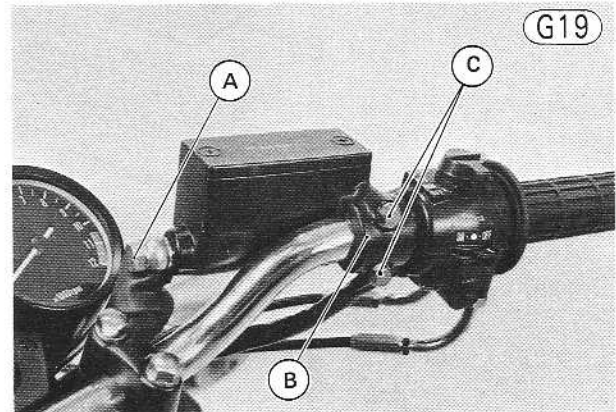

A. Banjo Bolt
B. Clamp

C. Clamp Bolts

- Remove the clamp bolts (2), and take off the master cylinder. There is a flat washer for each master cylinder clamp bolt. Immediately wipe up any brake fluid that is spilled.

Master Cylinder Installation Notes:

1. The master cylinder clamp is installed with the small projection facing the throttle grip. Tighten the upper clamp bolt first, and then the lower clamp bolt, to 0.8 kg-m (69 in-lbs) of torque.

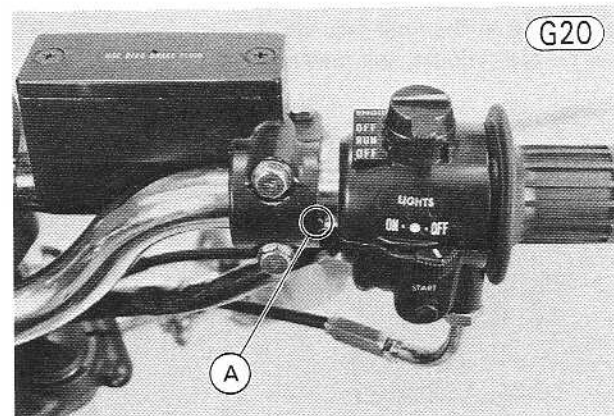

A. Small Projection

2. Bleed the brake line after master cylinder installation (Pg. 146).

Master Cylinder Disassembly:

- Remove the screws (2), take off the master cylinder cap (6) and diaphragm (5), and empty out the brake fluid.
- Remove the locknut (10) and pivot bolt (8), and remove the brake lever (9).

96 DISASSEMBLY—CHASSIS

Front Master Cylinder

G21

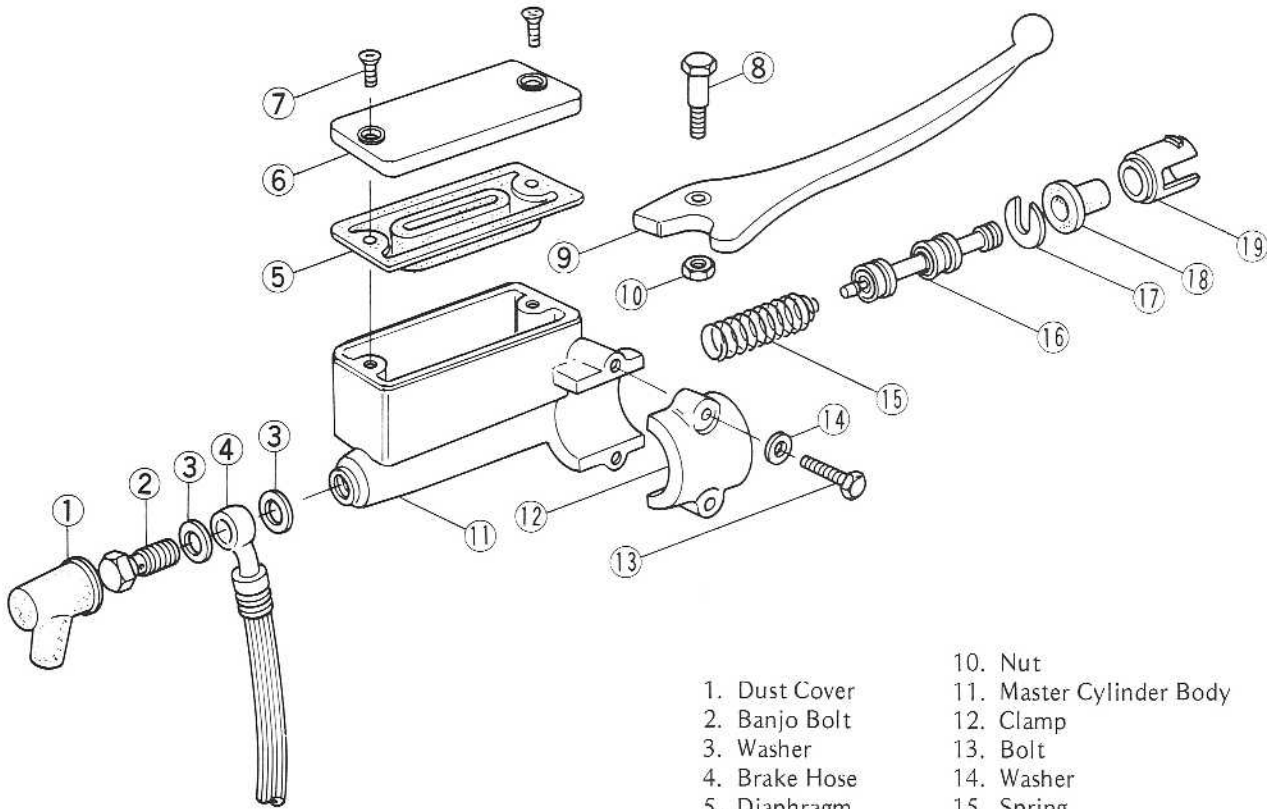

- | | |
|----------------|--------------------------|
| 1. Dust Cover | 10. Nut |
| 2. Banjo Bolt | 11. Master Cylinder Body |
| 3. Washer | 12. Clamp |
| 4. Brake Hose | 13. Bolt |
| 5. Diaphragm | 14. Washer |
| 6. Cap | 15. Spring |
| 7. Screw | 16. Piston |
| 8. Pivot Bolt | 17. Piston Stop |
| 9. Brake Lever | 18. Dust Seal |
| | 19. Liner |

- Using a thin-bladed screwdriver or some other suitable tool, press in the liner tabs which catch in the holes in the master cylinder, and then remove the liner ⑱.

- Pg. 92). Apply brake fluid to the parts removed and to the inner wall of the cylinder.
- 2. Be sure that the piston stop ⑰ is between the piston and dust seal ⑱.

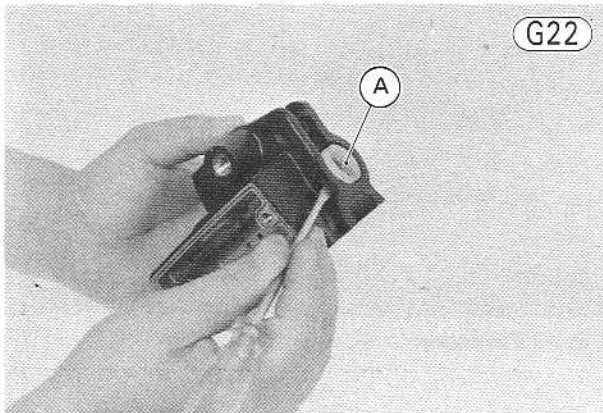

G22

A. Liner

- Pull out the piston and spring unit ⑯.

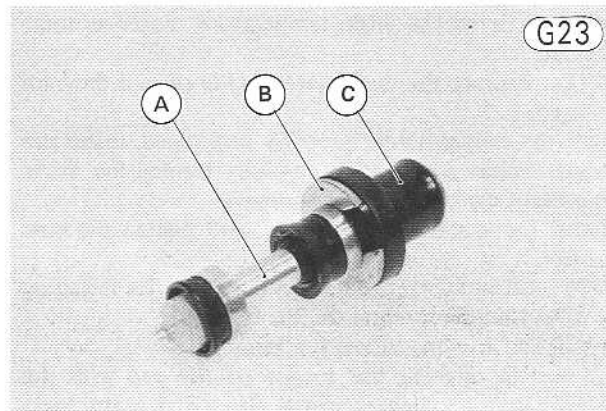

G23

A. Piston

B. Piston Stop

C. Dust Seal

Master Cylinder Assembly Notes:

1. Before assembly, clean all parts including the master cylinder with brake fluid or alcohol (SEE CAUTION

Brake Hose Replacement:

- Pump the brake fluid out of the line as explained in the Maintenance Section — Changing the brake fluid (Pg. 145).

- Remove the banjo bolts at the caliper and master cylinder, and remove the brake hose. There is a flat washer on each side of the hose fitting.
- Connect the new brake hose to the caliper and master cylinder, putting a new flat washer on each side of the brake hose fittings.
- Fill the reservoir with fresh brake fluid, and bleed the brake line (Pg. 145).

DRIVE CHAIN

Removal:

- Check to see that the transmission is in neutral.
- Remove the engine sprocket cover (Pg. 54). The clutch cable does not require removal from the clutch release.
- Remove the clip from the drive chain master link using pliers, and remove the master link.

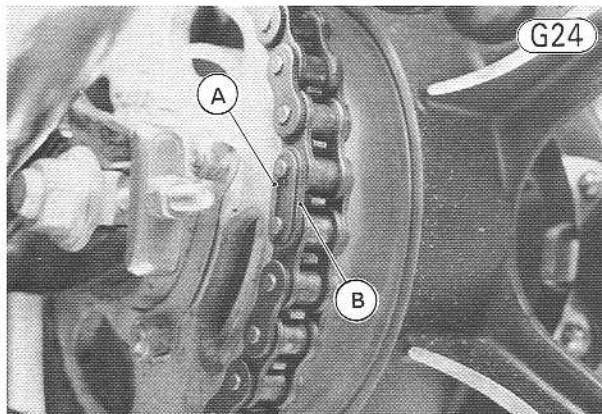

A. Clip

B. Master Link

- Free the drive chain from the sprockets, being careful that the chain does not get dirty from contact with the ground.

Installation:

- Fit the drive chain back onto the sprockets with the ends at the rear sprocket.
- Install the master link.
- Install the master link clip with pliers. The direction of the master link clip must be as shown.

WARNING Incorrect installation of the master link clip can allow it to catch on an adjacent part. If the clip dislodges, the chain could come apart, and this could result in rear wheel lockup and loss of control.

Master Link Clip Installation

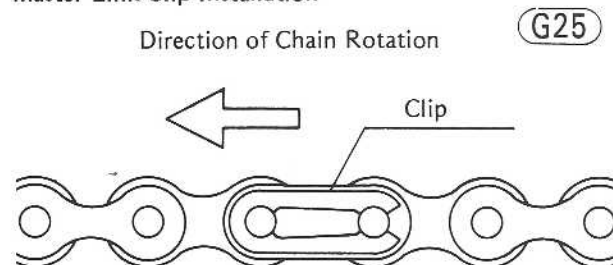

- Install the engine sprocket cover (Pg. 54).
- Adjust the drive chain (Pg. 24).
- Adjust the rear brake (Pg. 25).

REAR WHEEL

Removal:

- Raise the rear wheel off the ground.
- Remove the clip and master link from the drive chain, and remove the drive chain from the rear sprocket.
- Remove the locknut and bolt at the rear end of the torque link.

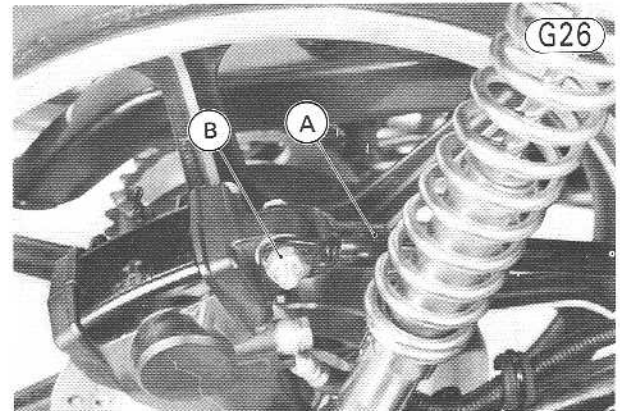

A. Torque Link

B. Locknut

- Loosen the rear axle nut, and remove the rear wheel together with the rear caliper by pulling them toward the rear.

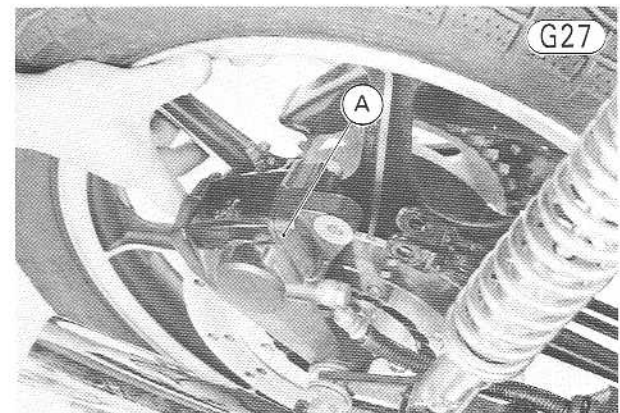

A. Caliper

- Remove the axle nut and left chain adjuster. Then pull off the axle with the right chain adjuster while holding up the caliper.
- Free the caliper from the disc, and insert a wood wedge (4 ~ 5 mm thick) between the disc brake pads. This prevents them from being moved out of their proper position, should the brake pedal be pushed accidentally.

CAUTION Do not lay the wheel down on the brake disc. This can damage or warp the disc. Place blocks under the wheel so the disc does not touch the ground.

- Fit the caliper to the torque link, and run the axle through the swing arm and the caliper holder to prevent the caliper from dangling.
- The rear caliper can be removed by disconnecting the rear end of the brake hose from the caliper.

98 DISASSEMBLY—CHASSIS

Rear Hub

G28

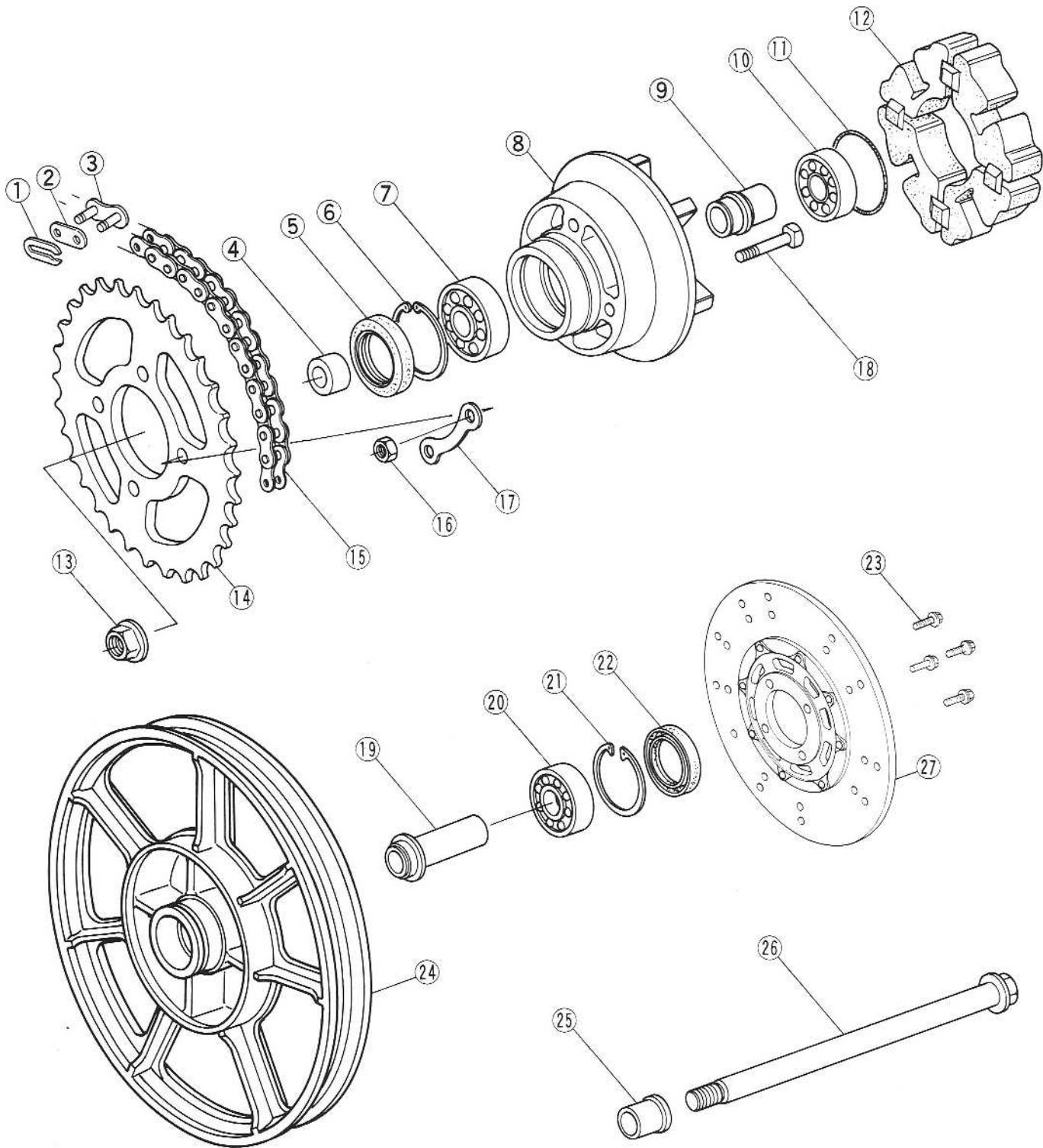

- | | | | |
|--------------------|--------------------|---------------------|-----------------|
| 1. Clip | 8. Coupling | 15. Drive Chain | 22. Grease Seal |
| 2. Side Plate | 9. Coupling Sleeve | 16. Nut | 23. Bolt |
| 3. Master Link | 10. Ball Bearing | 17. Double Washer | 24. Wheel |
| 4. Coupling Collar | 11. O Ring | 18. Bolt | 25. Collar |
| 5. Grease Seal | 12. Rubber Damper | 19. Distance Collar | 26. Rear Axle |
| 6. Circlip | 13. Axle Nut | 20. Ball Bearing | 27. Disc |
| 7. Ball Bearing | 14. Rear Sprocket | 21. Circlip | |

Installation:

- Remove the wedge from between the brake pads, and pull the rear axle off the caliper holder and the swing arm.
- Apply a little grease to the inside surface of the hole in the coupling where the rear hub fits.
- Check to see that the wheel coupling collar, coupling sleeve, rubber damper, and hub collar are in place.
- Slip the rear wheel and coupling assembly back from the left rear.
- Put the caliper on the disc so that the disc is between the pads.
- Run the axle through the right chain adjuster, rear caliper holder, collar, rear hub, coupling, coupling collar, and left chain adjuster. Then screw on the axle nut.
- Put the rear wheel into the swing arm end.
- Fit the drive chain onto the rear sprocket and install the drive chain master link and clip.
- Fit the rear caliper into the torque link end, insert the bolt through them from left to right, and put on the torque link nut fingertight.
- Adjust the drive chain (Pg. 24).
- Adjust the rear brake (Pg. 25).
- Check the fluid level in the master cylinder, and bleed the brake line (Pg. 145).

Wheel Coupling Disassembly:

- Straighten the bent portions of the double washers ⑰ (2).

CAUTION Do not lay the wheel down on the brake disc. This can damage or warp the disc. Place blocks under the wheel so that disc does not touch the ground.

- Remove the rear sprocket nuts ⑬ (4) and the double washers to separate the rear sprocket ⑭ and wheel coupling ⑧.
- Remove the rear sprocket and remove the coupling from the rear wheel.
- Pull out the coupling collar ④ from the left, and the coupling sleeve ⑨ from the right.
- Using a hook, pull out the grease seal ⑤ and remove the circlip ⑥.

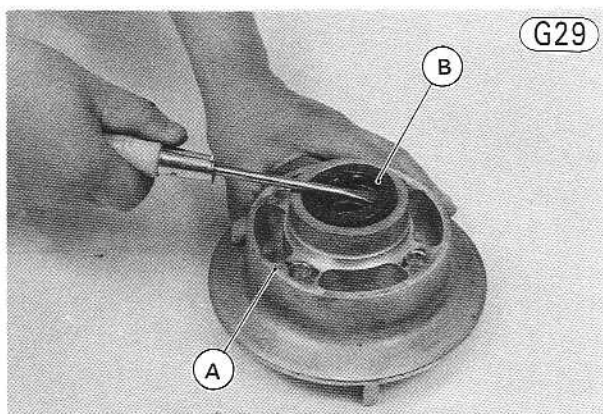

A. Wheel Coupling

B. Grease Seal

- Remove the bearing ⑦ by tapping evenly around the bearing inner race from the right side.

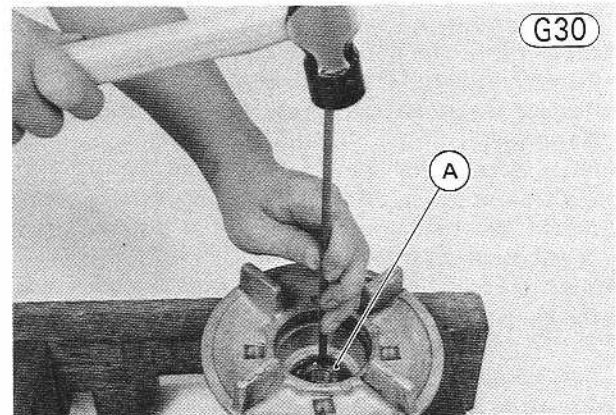

A. Bearing

Wheel Coupling Assembly:

- Lubricate the new wheel bearing (Pg. 143) and install it using the wheel bearing driver and the bearing driver holder (special tools). Press the bearing in until it stops at the bottom of the hole.

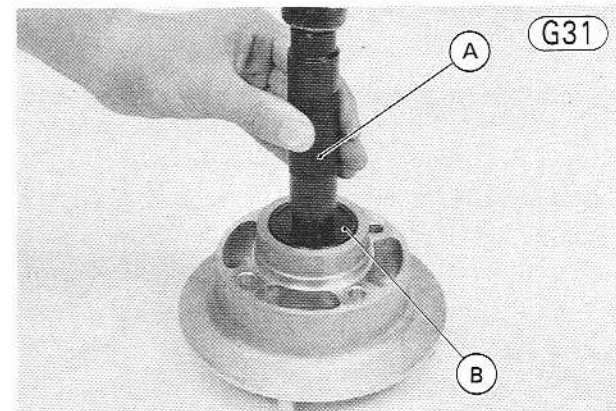
A. Bearing Driver Holder (57001-139)
B. Bearing Driver (57001-289)

- Install the circlip.
- Install a new grease seal using the bearing driver (special tool: PN57001-289) and bearing driver holder. Drive in the seal until the face of the seal is flush with the end of the grease seal hole. Apply a little grease to the grease seal lip.
- Install the coupling sleeve on the right side and the coupling collar on the left side of the coupling.
- Install the rear sprocket with the numbered side facing outward, using the bolts (4), new double washers (2), and nuts (4). Do not tighten the nuts yet.
- Inspect the O ring ⑪ on the rear hub, replace it with a new one if it is deteriorated, and apply a little grease to the O ring.
- Install the rubber damper and wheel coupling on the rear hub, and tighten the sprocket nuts to 3.0 kg-m (22 ft-lbs) of torque.
- Bend the tab portions of the double washers over the nuts.

Rear Hub Disassembly

(including disc removal):

- Remove the wheel coupling (8) and rubber damper (12) from the rear hub (24).
- Pull out the collar (25) from the disc side.
- Remove the bolts (4) and rear disc.
- Remove the grease seal (22) using a hook, and remove the circlip (21).
- Insert a metal rod into the hub from the disc side, and remove the left side bearing (10) by tapping evenly around the bearing inner race. The distance collar (19) will come out with the bearing.
- Insert the metal rod into the hub from the other side, and tap out the remaining bearing (20).

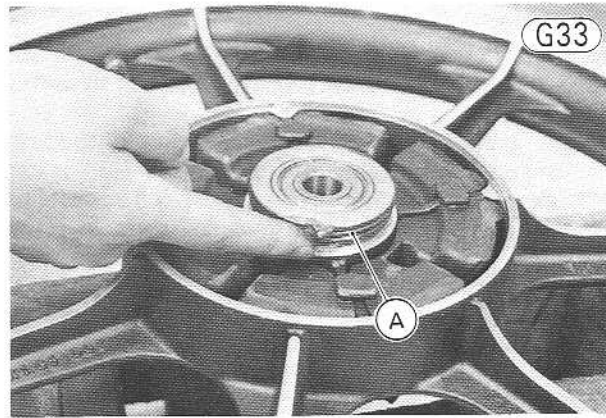

A. O Ring

Rear Hub Assembly:

- Lubricate the new ball bearing (Pg. 143).
- Before installing the wheel bearings, blow any dirt or foreign particles out of the hub with compressed air.
- Install the disc side ball bearing using the wheel bearing driver and the bearing driver holder (special tools). Press the bearing in until it stops at the bottom of the hole.

NOTE: The wheel bearing must be installed with the shielded side facing outward.

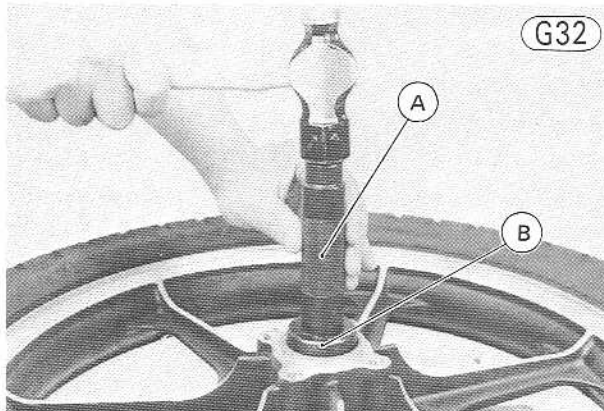

A. Bearing Driver Holder (57001-139)
B. Bearing Driver (57001-290)

- Put the distance collar into the hub. The flanged side must face the left (Fig. G6).
- Install the coupling side bearing with the shielded side facing outward. Press the bearing in until it stops at the bottom of the hole, using the same special tools used for the other bearing installation.
- Install the circlip.
- Inspect the grease seal for damage and replace it if necessary (Pg. 143). Press it in until it stops at the bottom of the hole using the wheel bearing driver and the bearing driver holder (special tools PN 57001-139 and 57001-291).
- Inspect the O ring on the rear hub for damage and replace it if necessary. Apply a little grease to the O ring before fitting the coupling on the rear hub.

REAR BRAKE

Removal, installation, disassembly, and assembly of the rear disc brake is divided as follows:

- Pad Removal and Installation
- Caliper Disassembly and Assembly
- Master Cylinder Removal
- Master Cylinder Installation Notes
- Master Cylinder Disassembly
- Master Cylinder Assembly

NOTES:

1. Disc removal and disc installation are covered in the rear hub disassembly and assembly sections (See above).
2. Caliper removal and caliper installation are covered in the rear wheel removal and installation sections (Pg. 97).
3. Refer to the CAUTION (Pg. 92) for general disc brake information.

Pad Removal:

- Remove the pad cover on the caliper.

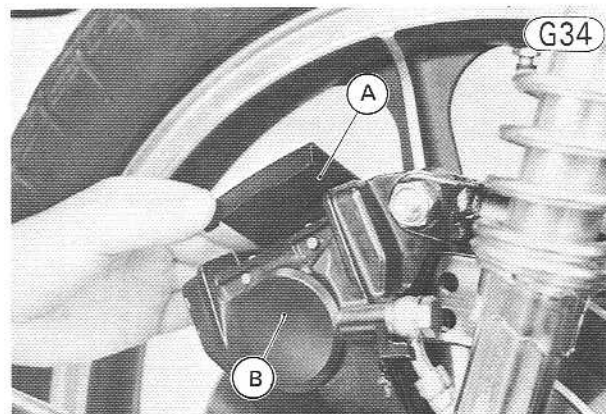

A. Pad Cover B. Caliper

- Remove the clips (2) from the pins (2).
- Holding a thumb on the anti-rattle springs to keep them from flying off, pull the pins off the caliper.

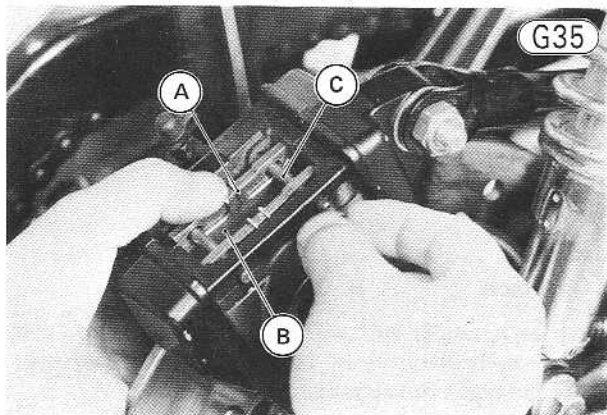

A. Anti-rattle Spring C. Pin
B. Pad

- Remove the pads (2) from the caliper.

Pad Installation:

- Remove the bleed valve cap, attach a clear plastic hose to the bleed valve, and run the other end of the hose into a container.
- Open (loosen) the valve slightly, push both pistons in by hand as far as they will go, using a worn pad; then close (tighten) the valve. Wipe up any spilled fluid, and recap the bleed valve.

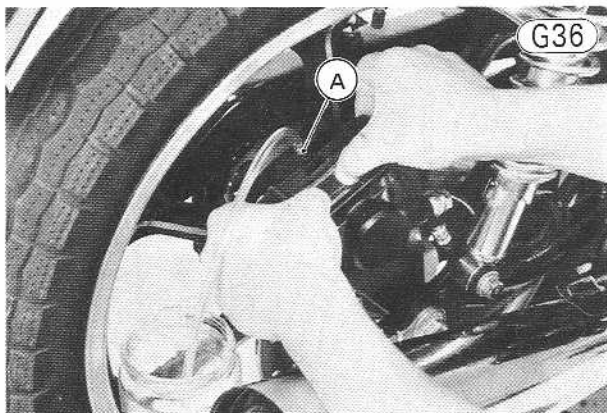

A. Bleed Valve

CAUTION

Do not lever the pistons with a screwdriver against the disc. This can damage or warp the disc.

- Insert one of the pins through the outer wall of the caliper, through the pads, and into the inner wall of the caliper.
- Install the anti-rattle springs. Be sure that the end of each spring goes under the installed pin, and that the top of each spring rides on the pad.

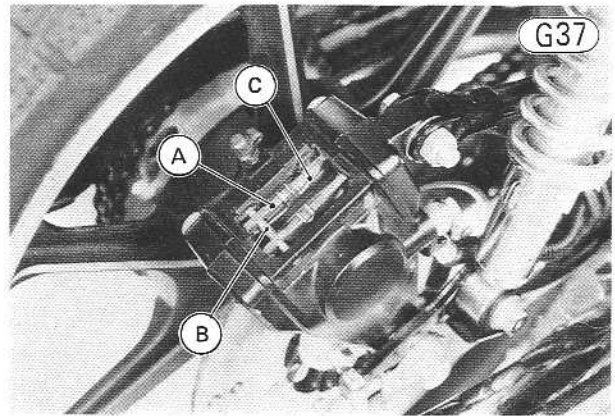

A. Pad C. Anti-rattle Spring
B. Pin

- Insert the other pin through the caliper and pads, pressing down on the end of each spring so that the pin can pass over it.

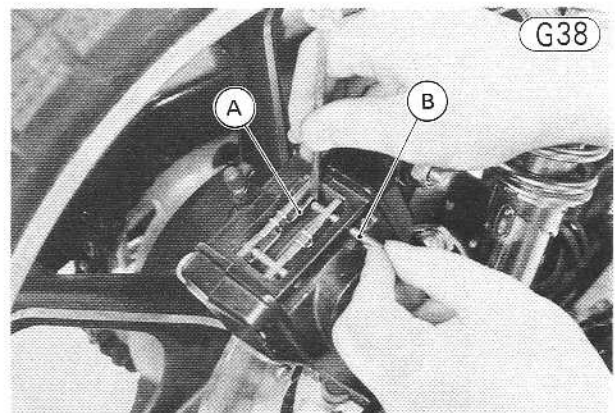

A. Anti-rattle Spring B. Pin

- Insert the clips through the pins.
- Install the pad cover.
- Since some brake fluid was lost when the bleed valve was opened, check the fluid level in the master cylinder and bleed the air from the brake system (Pg. 145).
- Push the bleed valve cap onto the valve.

WARNING The rear brake pedal must be pumped to move the brake pads into operating position. If this is not done, the first few applications of the brake may be ineffective and an unsafe riding condition could result.

Rear Caliper Disassembly:

- Remove the rear caliper (see rear wheel removal, Pg. 97).
- Remove the pads as explained in the pad removal section (Pg. 100).
- Remove the Allen bolts (3) (2) and the left caliper half (1).

102 DISASSEMBLY—CHASSIS

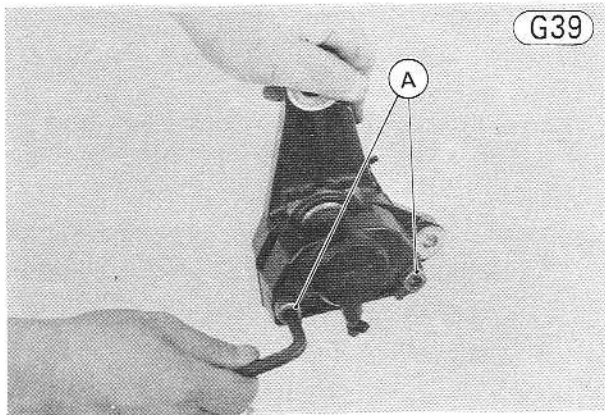

G39

A. Allen Bolts

- Remove the O ring (12) (2) and the dust seals (6) around the pistons.

Rear Caliper

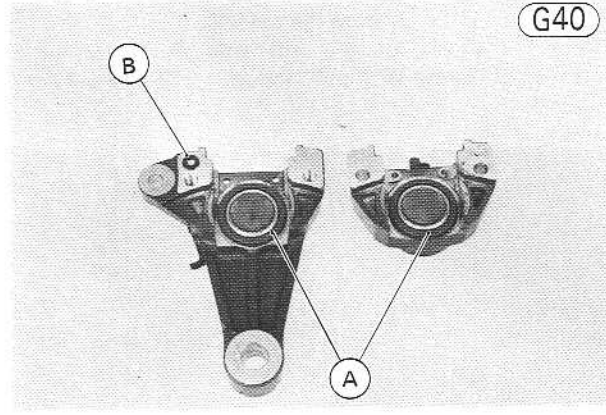

G40

A. Dust Seals

B. O Ring

- Wrap each caliper half with a clean, heavy cloth, and remove each piston (5) by lightly applying compressed air to the brake fluid passage.

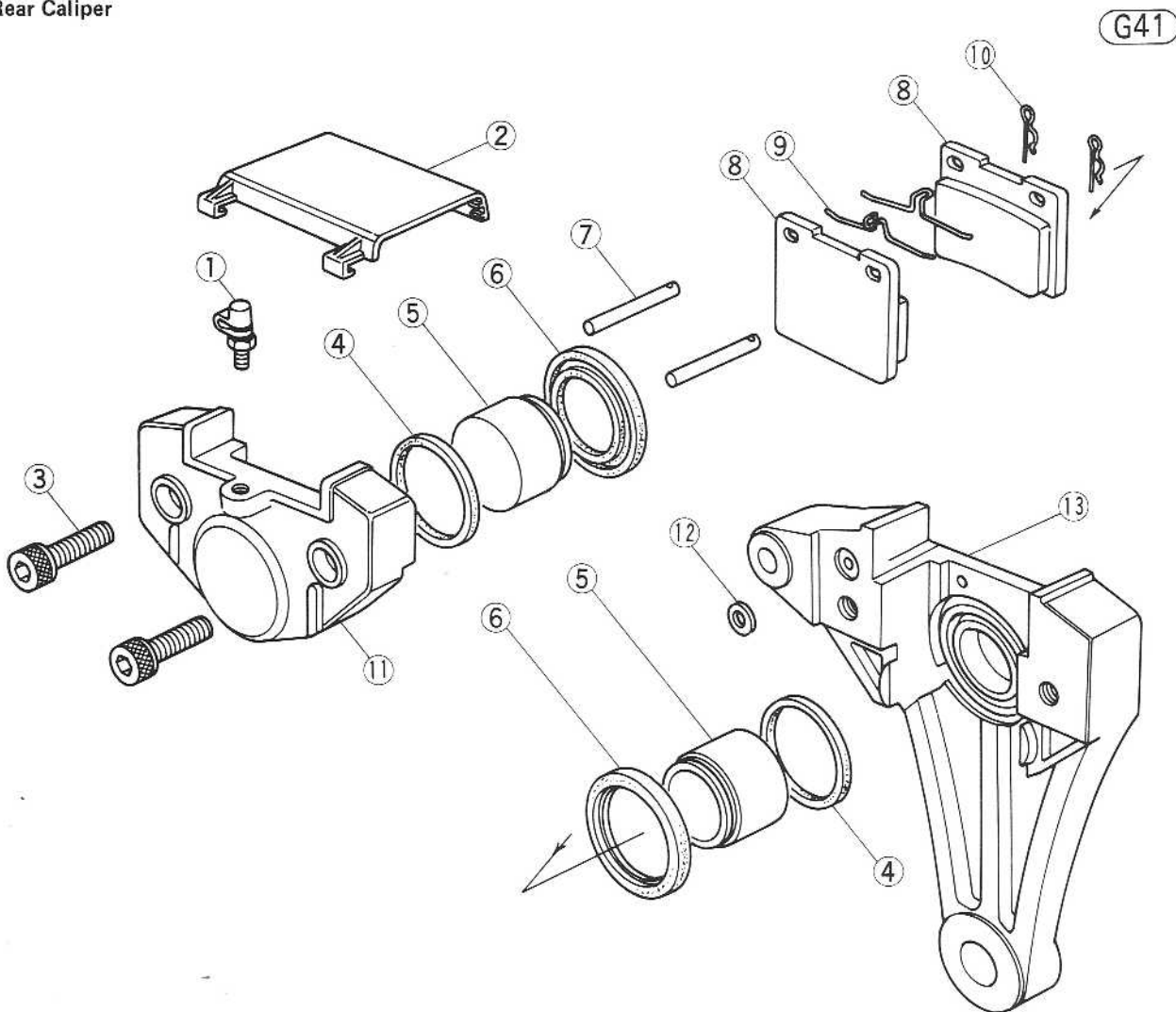

G41

1. Bleed Valve
2. Pad Cover
3. Allen Bolt
4. Fluid Seal

5. Piston
6. Dust Seal
7. Pin

8. Pad
9. Anti-rattle Spring
10. Clip

11. Left Caliper Half
12. O Ring
13. Right Caliper Half

WARNING To avoid serious injury, never place your fingers or palm on the piston. If you apply compressed air into the caliper, the piston may crush your hand or fingers.

- Taking care not to damage the cylinder surfaces, remove the fluid seals with a hook.

Caliper Assembly:

- Clean the caliper parts with brake fluid or alcohol (See CAUTION – Pg. 92).
- Fit a new fluid seal in place inside each cylinder.

NOTE: It is recommended that you replace any rubber parts that have been removed.

- Apply brake fluid to the outside of each piston and fluid seal, and then push the piston into the cylinder by hand. Take care that neither the cylinder nor the piston skirt is scratched.
- Install a new dust seal around each piston. Check that the dust seals are properly fitted into the grooves in the piston and the caliper halves.
- Fit a new O ring onto the right caliper half, and install the left caliper half with the Allen bolts.
- Tighten the Allen bolts to 3.0 kg-m (22 ft-lbs) of torque.
- Install the pads as explained in the pad installation section (Pg. 92).
- Install the rear wheel (Pg. 97).
- Adjust the drive chain (Pg. 24).
- Check the fluid level in the master cylinder, and bleed the brake line (Pg. 145).

Rear Master Cylinder Removal:

- Pull off the right side cover.
- Remove the banjo bolt to disconnect the brake hose from the master cylinder. There is a flat washer on each side of the hose fitting. Immediately wipe up any brake fluid that spills.

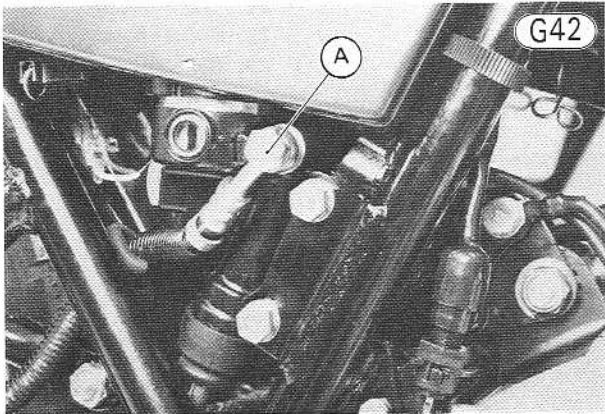

A. Banjo Bolt

- Remove the master cylinder mounting bolts, lock-washers, and flat washers (2 ea), and free the rear master cylinder from the motorcycle.

Rear Master Cylinder Installation Notes:

1. Replace the flat washer on each side of the brake hose fitting with new ones.
2. Bleed the brake line after master cylinder installation (Pg. 146).
3. Adjust the rear brake (Pg. 25).

Rear Master Cylinder Disassembly:

- Remove the push rod dust cover ①.
- Take off the master cylinder cap ① and diaphragm ③, and empty the brake fluid into a suitable container.
- Remove the retainer ⑬ with a thin screwdriver, and pull out the piston stop ⑭ and piston ⑫. Do not remove the secondary cup ⑬ from the piston since removal will damage the cup.

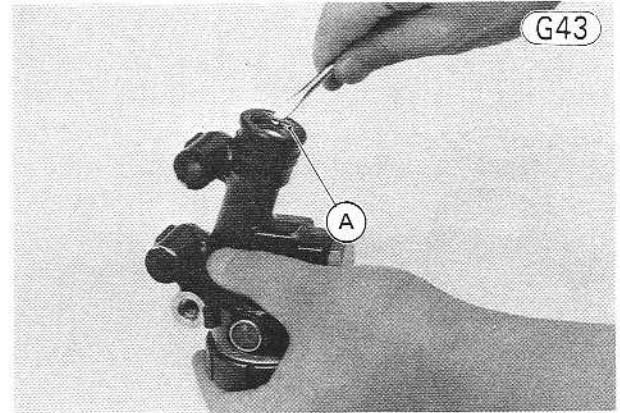

A. Retainer

- Remove the return spring ⑩ and primary cup ⑪ by lightly applying compressed air into the outlet hole.

Rear Master Cylinder Assembly:

- Before assembly, clean all parts including the master cylinder with brake fluid or alcohol (See CAUTION – Pg. 92), and apply brake fluid to the parts and the inner wall of the cylinder. Take care not to scratch the piston or the inner wall of the cylinder.
- Put the return spring into the cylinder. The spring seat side must face out.
- Install the primary cup. Be sure that the primary cup is not installed backward or turned sideways after insertion.

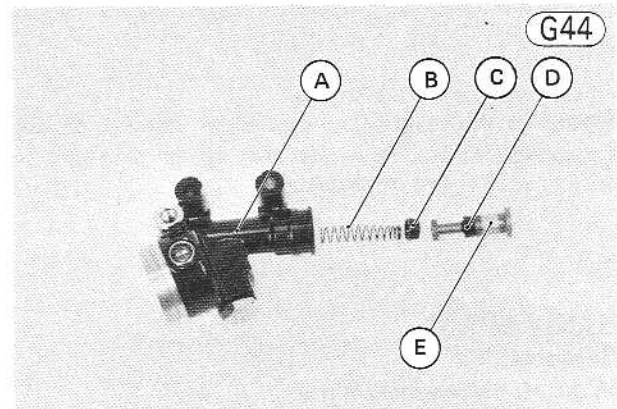

A. Master Cylinder

B. Spring

C. Primary Cup

D. Secondary Cup

E. Piston

- Install the piston and stop, and with a suitable rod, install the retainer to hold the piston in as far as it will go.
- Install the diaphragm and the master cylinder cap.

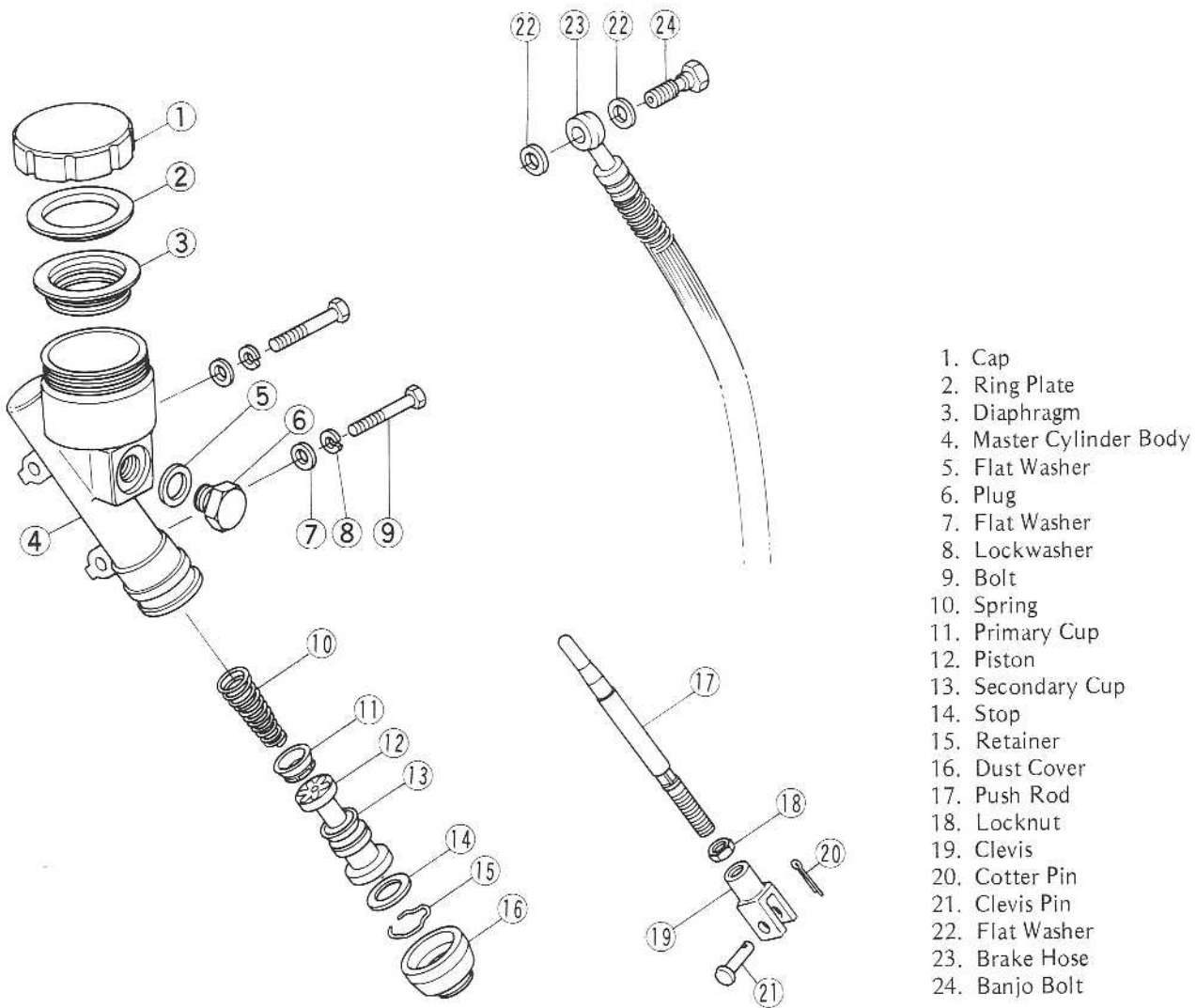

1. Cap
2. Ring Plate
3. Diaphragm
4. Master Cylinder Body
5. Flat Washer
6. Plug
7. Flat Washer
8. Lockwasher
9. Bolt
10. Spring
11. Primary Cup
12. Piston
13. Secondary Cup
14. Stop
15. Retainer
16. Dust Cover
17. Push Rod
18. Locknut
19. Clevis
20. Cotter Pin
21. Clevis Pin
22. Flat Washer
23. Brake Hose
24. Banjo Bolt

●Install the push rod dust cover.

NOTE: If the plug ⑥ and gasket are removed, replace the gasket with a new one and tighten the plug to 4.5 kg-m (33 ft-lbs) of torque.

HANDLEBAR

Removal:

- Take off the rear view mirrors.
- Remove the fuel tank (Pg. 39) or cover it with a thick cloth to avoid damaging the painted surface.
- Loosen the locknut, and turn the adjuster at the center of the clutch cable in fully to give the cable plenty of play.
- Remove the clutch adjusting cover.
- Loosen the locknut, and turn in the clutch adjusting screw a couple of turns to give the clutch cable plenty of play.

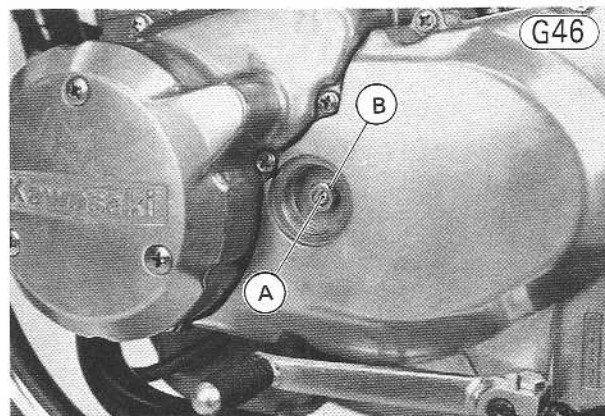

A. Adjusting Screw

B. Locknut

- Loosen the knurled locknut on the clutch lever, and turn in the adjuster and line up the slots in the clutch lever, locknut, and adjuster. Remove the inner cable from the lever.

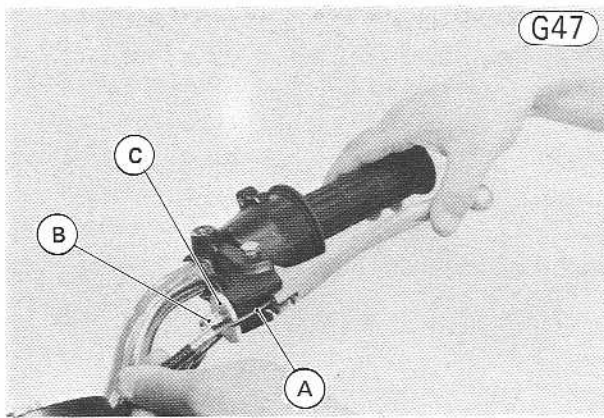

A. Clutch Inner Cable **C. Knurled Locknut**
B. Adjuster

- Remove the straps which hold the left switch wiring harness and right switch wiring harness to the handlebar.
- Take out the screws (2), and remove the left switch housing from the handlebar. If necessary, loosen the clutch lever holder bolt, and slide the clutch lever to the right.
- Remove the screws (2), and open up the right switch housing.
- Loosen the master cylinder clamp bolts (2).

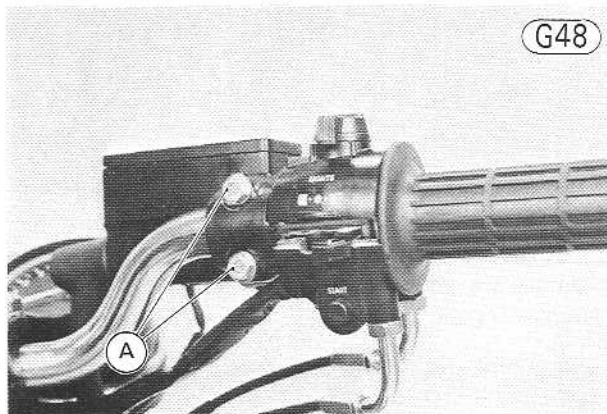

A. Clamp Bolts

- Remove the handlebar clamp bolts and lockwashers (4 ea), remove the clamps (2), and slide the handlebar from the throttle grip, right switch housing, and master cylinder.

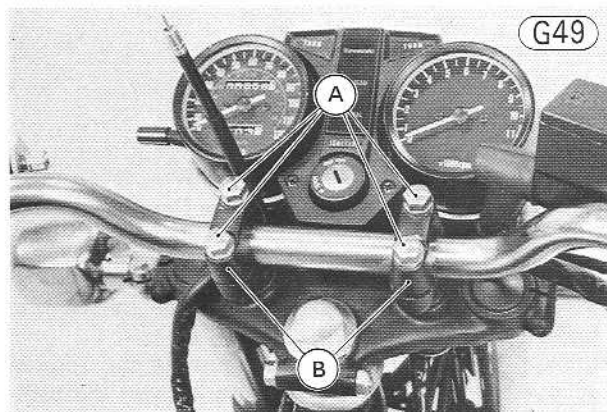

A. Clamp Bolts **B. Clamps**

- To remove the clutch lever, loosen the clutch lever holder bolt, cut off the left hand grip, which is bonded to the handlebar, and slide off the clutch lever.

Installation:

- If the clutch lever and left hand grip were removed; slide the clutch lever back on, hand tighten its bolt, and bond a new left hand grip to the handlebar.
- Slide the right side of the handlebar through the master cylinder and the right switch housing, and into the throttle grip assembly.
- Mount the handlebar, and install the handlebar clamps, lockwashers, and clamp bolts so that the angle of the handlebar matches the angle of the front fork as shown, and tighten the clamp bolts evenly to 1.8 kg-m (13.0 ft-lbs) of torque.

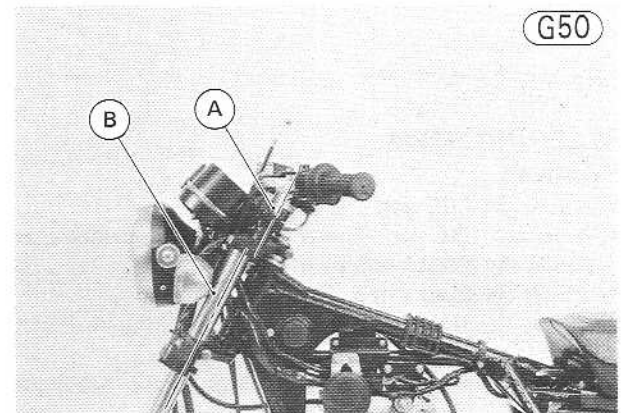

A. Handlebar **B. Front Fork**

- Install the left switch housing using its screws (2). The front switch housing screw is longer than the rear screw.
- Put together the right switch housing and tighten its screws. The upper half of the housing has a small projection which fits into a small hole in the handlebar. The front switch housing screw is longer than the rear screw.

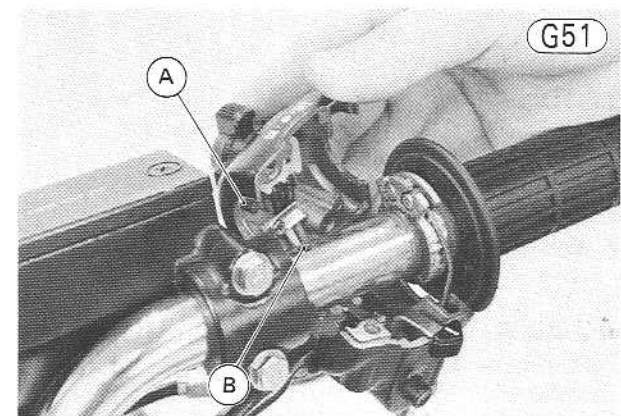

A. Projection **B. Hole**

106 DISASSEMBLY—CHASSIS

- With the brake lever mounted at the proper angle, tighten first the upper and then the lower master cylinder clamp bolt to 0.8 kg-m (69 in-lbs) of torque.
- With the clutch lever mounted at the proper angle tighten the clutch lever holder bolt.
- Strap the left and right switch housing harnesses on the handlebar.
- Fit the tip of the clutch cable back into the clutch lever.
- Install the fuel tank (Pg. 39).
- Check the front brake (Pg. 25).
- Check the throttle cable (Pg. 17).
- Adjust the clutch (Pg. 20).
- Install the rear view mirrors.
- Adjust the rear view mirrors.

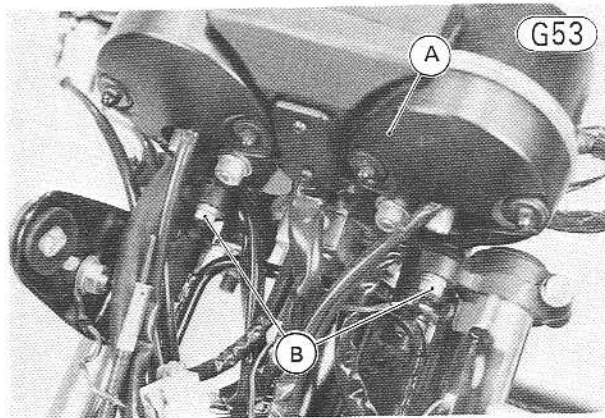

A. Meter Assembly

B. Locknut

- Remove the bolts (2) and cable guide from the steering stem base.

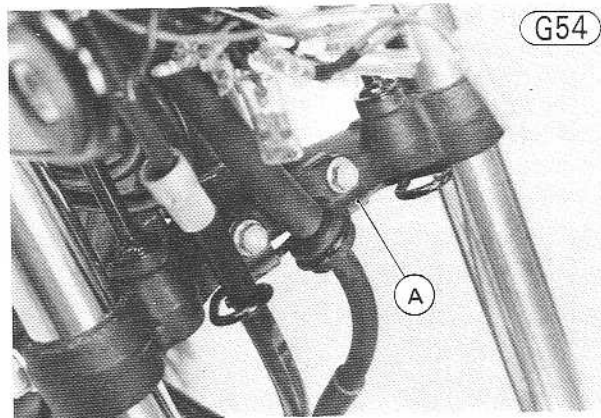

A. Guide

- Remove the grommet from the brake hose guide on the left fork leg.

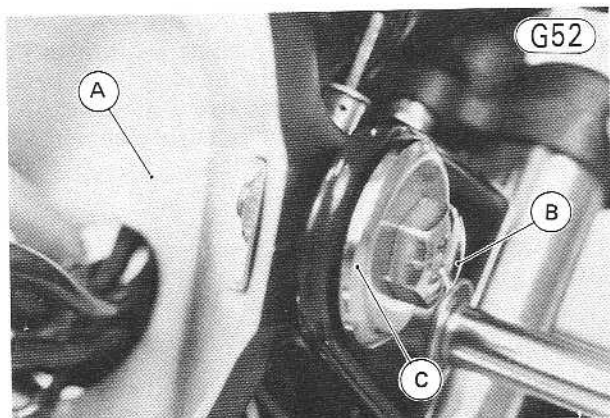

A. Headlight Housing
B. Mounting Bolts

C. Washer

- Remove the nuts, lockwashers, and flat washers (2 ea), and remove the instrument panel from the steering stem head.

CAUTION

If a meter is left upside down or sideways for any length of time, it will malfunction.

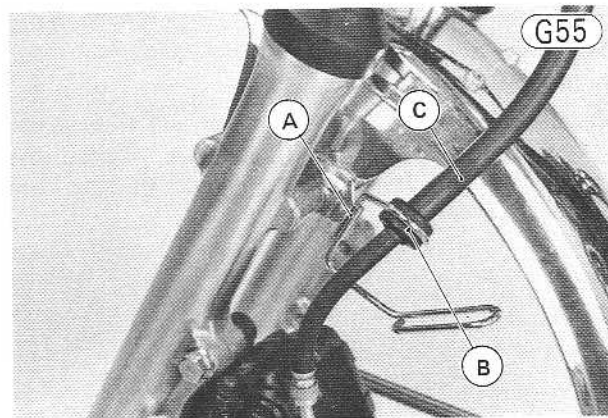

A. Brake Hose Guide
B. Grommet

C. Brake Hose

- Remove the master cylinder and brake caliper with brake hose from the frame.
- Loosen the locknut, and fully turn in the adjuster at the center of the clutch cable to give the cable plenty of play.
- Remove the clutch adjusting cover.

- Loosen the locknut, and turn in the clutch adjusting screw a couple of turns to give the clutch cable plenty of play.

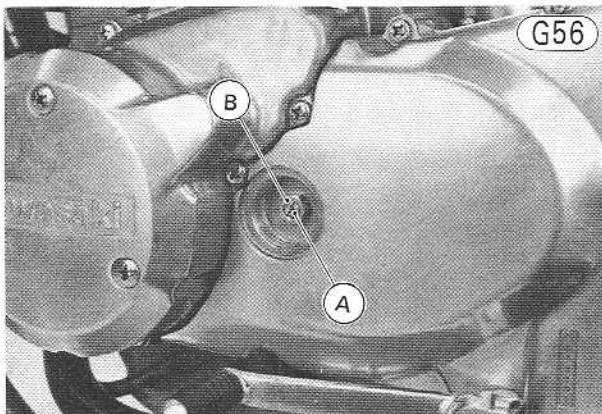

A. Adjusting Screw B. Locknut

- Loosen the knurled locknut on the clutch lever holder, and screw in the adjuster, lining up the slots in the clutch lever, knurled locknut, and adjuster. Remove the inner cable from the lever.

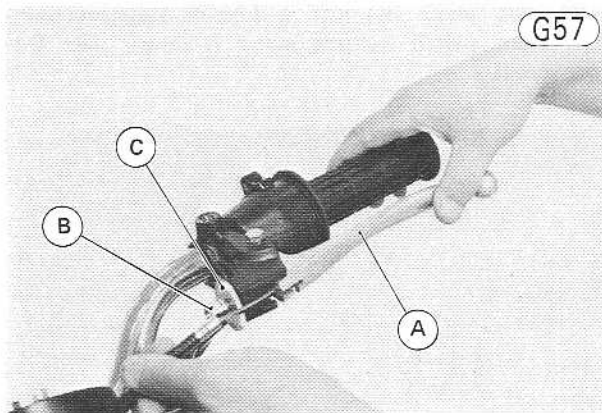

A. Clutch Lever C. Knurled Locknut
B. Adjuster

- Remove the straps which hold the right and left switch wiring harness to the handlebar.
- Remove the right and left switch housing screws (4) and open the housings.
- Loosen the front fork upper clamp bolts (2).

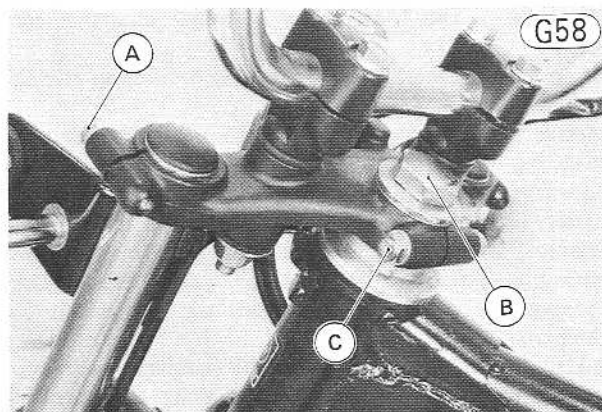

A. Fork Upper Clamp Bolt C. Head Clamp Bolt
B. Stem Head Bolt

- Loosen the stem head clamp bolt, and remove the stem head bolt, flat washer, and lockwasher.
- Tap lightly on the bottom of the stem head with a mallet, and remove the steering stem head with the handlebar and ignition switch. Slide the handlebar from the throttle grip and the right switch housing.
- Slide off the headlight bracket with the turn signal from each of the front fork legs.

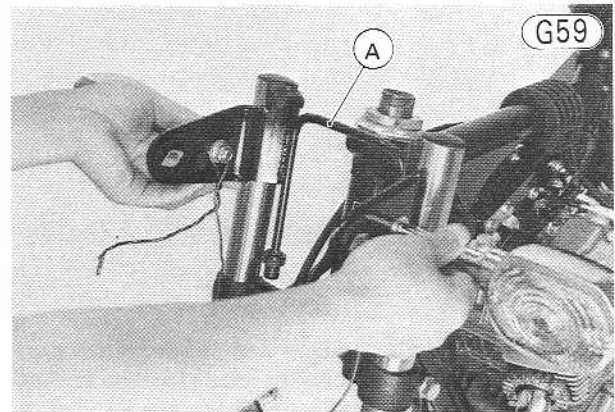

A. Headlight Bracket

- Loosen the lower clamp bolts (2), and pull out the fork legs and fender.
- Push up on the stem base, and remove the steering stem locknut with the stem nut wrench (special tool); then remove the steering stem and stem base (single unit). As the stem is removed, some of the steel balls will drop out of the lower outer race. Remove the remaining balls. There are 19 steel balls in the lower outer race.

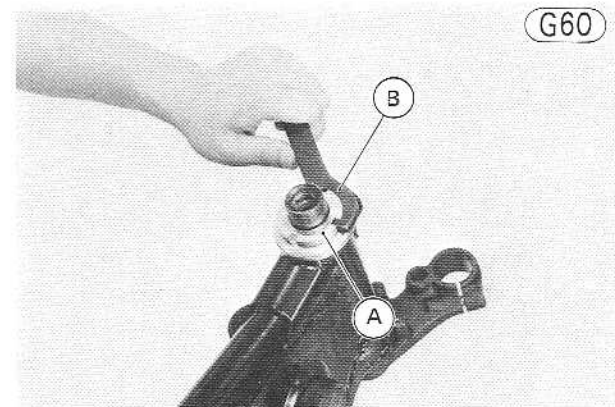

A. Stem Locknut
B. Stem Nut Wrench (57001-134)

- Remove the steering stem cap, the upper inner race, and the upper steel balls (19).

Installation:

- Apply grease to the upper and lower outer races in the head pipe so that the steel balls will stick in place during stem insertion. Install the upper steel balls

108 DISASSEMBLY—CHASSIS

(19) and lower steel balls (19). All the steel balls are same size.

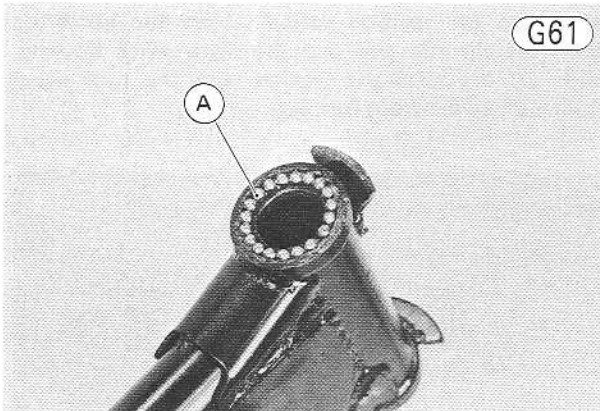

A. Steel Balls

- Put on the upper inner race and steering stem cap. Insert the steering stem into the head pipe, and tighten the steering stem locknut to 2.0 kg-m (14.5 ft-lbs) of torque.
- Run each fork tube up through its clamp in the stem base. Temporarily tighten the lower clamp bolts to hold the fork legs in place with the legs protruding about 170 mm above the steering stem base.
- Place the throttle cables and right switch housing harness between the head pipe and the right fork tube. Place the left switch housing harness and main wiring harness between the head pipe and the left fork tube.
- Install the headlight bracket between the front fork legs.

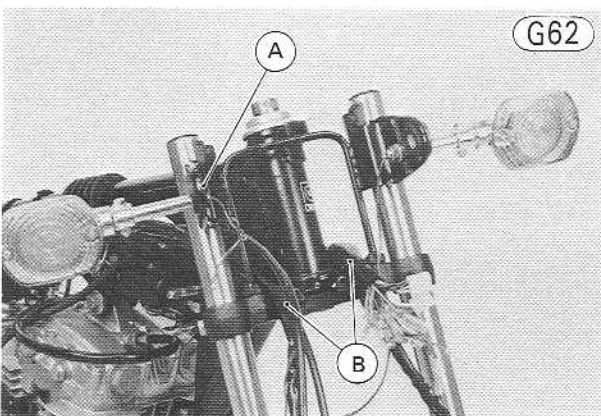

A. Headlight Bracket B. Wire Harness

- Slide the right side of the handlebar through the right switch housing, and into the throttle grip assembly.
- Fit the stem head and handlebar onto the steering stem and fork tubes. Put on the lockwasher and flat washer and screw in the stem head bolt.
- For each fork leg, loosen the lower clamp, and align the upper end of the front fork inner tube with the upper surface of the stem head. Tighten the upper clamp bolt to 1.8 kg-m (13.0 ft-lbs) of torque.

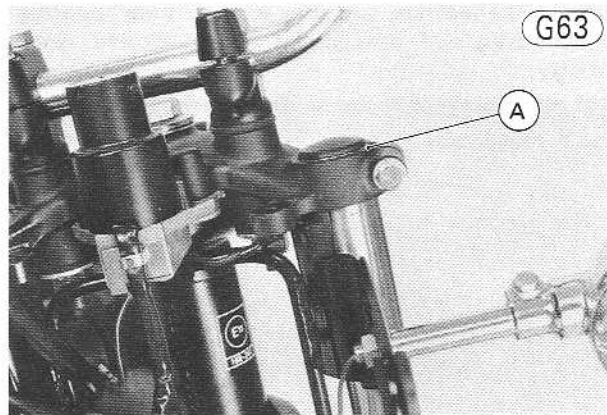

A. Inner Tube Upper End

- Tighten the stem head bolt to 4.0 kg-m (29 ft-lbs) of torque and the stem head clamp bolt to 1.8 kg-m (13.0 ft-lbs) of torque.
- Tighten the front fork lower clamp bolts to 2.5 kg-m (18 ft-lbs) of torque.
- Put together the right switch housing and tighten its screws. The upper half of the housing has a small projection which fits into a hole in the handlebar. The front switch housing screw is longer than the rear screw.

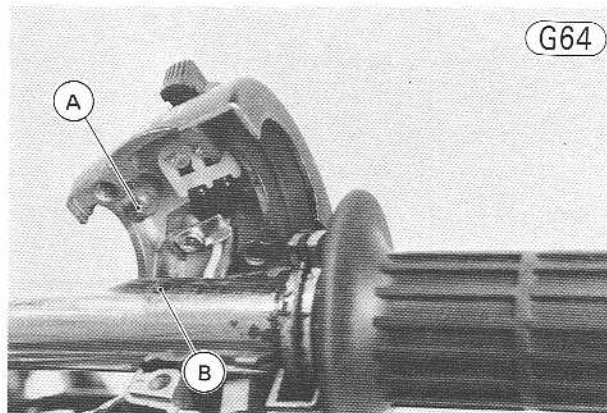

A. Projection B. Hole

- Position the left switch housing in place, and tighten its screws. The front screw is longer than the rear screw.
- Strap both the left and right switch housing wiring harness onto the handlebar.
- Mount the instrument panel onto the stem head so that the wire harnesses from both switch housings and front brake light switch lead run between the meters and the stem head. Install the nuts, lockwashers, and flat washers under the instrument panel.
- Run the upper end of the clutch cable between the speedometer and the stem head, and connect it to the clutch lever.
- Install the master cylinder on the handlebar with the small projection on the clamp facing the throttle grip (Fig. G20 on Pg. 95). Tighten first the upper clamp bolt and then the lower bolt, to 0.8 kg-m (69 in-lbs) of torque. Each clamp bolt has a flat washer.

- Install the caliper on the left front fork leg. Tighten the mounting bolts to 3.0 kg-m (22 ft-lbs) of torque. Each bolt has a lockwasher and flat washer.
- Install the cable guide on the steering stem base using the bolts (2).
- Secure the lower brake hose in its guide. Be sure the rubber grommet is in place.
- Run the speedometer and tachometer cables through the guide at the steering stem base, fit the inner cables into the meters, and tighten the cable nut with pliers.
- Run all the plugs, sockets, and wires into the headlight housing, and mount the headlight housing, tightening its mounting bolts. The sequence is mounting bolt flat washer, headlight bracket, collar, and nut.
- Connect the plugs and sockets in the headlight housing.
- Connect the wire from the left turn signal to the green wire and the wire from the right turn signal to the gray wire.
- Connect the remaining wires according to the color codes.
- Install the headlight unit.
- Install the front wheel (Pg. 89).
- Check the steering, and adjust it if necessary (Pg. 26).
- Install the fuel tank (Pg. 39).
- Check the front brake, and bleed the system if necessary (Pg. 25).
- Adjust the clutch (Pg. 20).
- Check the throttle cables, and adjust if necessary (Pg. 17).
- Adjust the rear view mirrors.

STEERING STEM BEARINGS

Removal:

- Remove the steering stem (Pg. 106).
- To remove the outer races pressed in the head pipe, insert a bar into the head pipe, and hammer evenly around the circumference of the opposite race to drive it out.

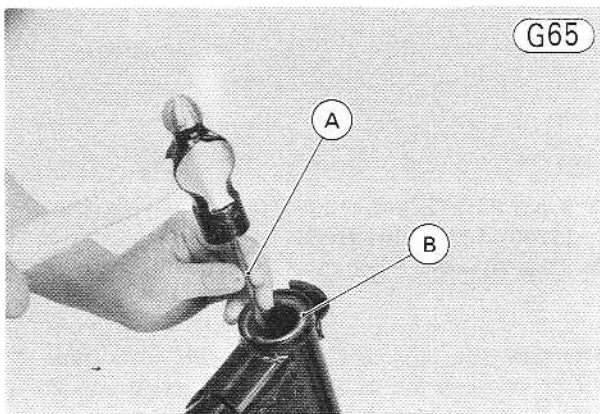

A. Bar

B. Outer Race

- To remove the lower inner race, which is pressed onto the steering stem, grip the stem in a vice and use a metal rod and hammer.

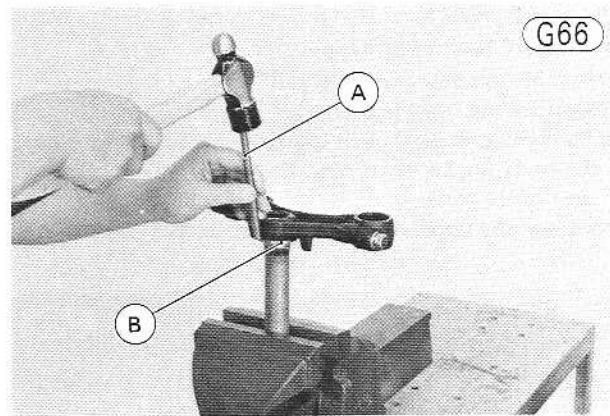

A. Rod

B. Lower Inner Race

Installation:

- Apply oil to the outer races, and drive the races into the head pipe using the stem cup driver and the bearing driver holder (special tools). Be sure to drive them in until they stop at the stepped portion in the head pipe.

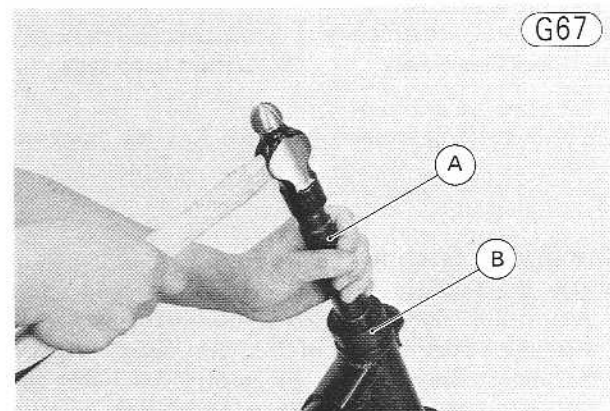

A. Bearing Driver Holder (57001-139)

B. Stem Cup Driver (57001-138)

- Apply oil to the lower inner race, and drive the race onto the steering stem using the stem bearing driver and adapter (special tools). Be sure to press it in until it stops at the stem base.

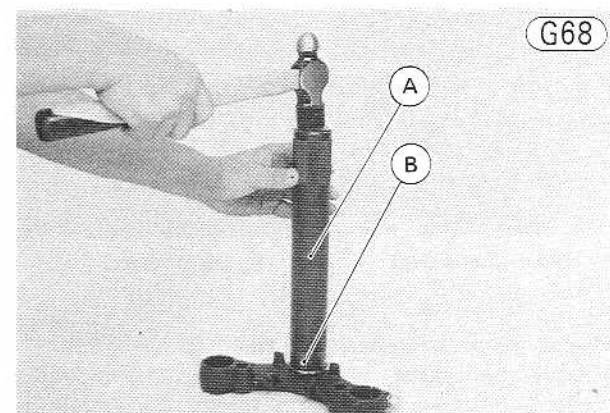

A. Stem Bearing Driver (57001-137)

B. Adapter (57001-294)

- Install the steering stem (Pg. 106).

FRONT FORK

Removal (each fork leg):

- Remove the front wheel (Pg. 89).
- Remove the front fender.
- To remove the left fork leg, remove the caliper mounting bolts, lockwashers, and flat washers (2 ea); and put the caliper aside.
- Loosen the upper and lower clamp bolts.

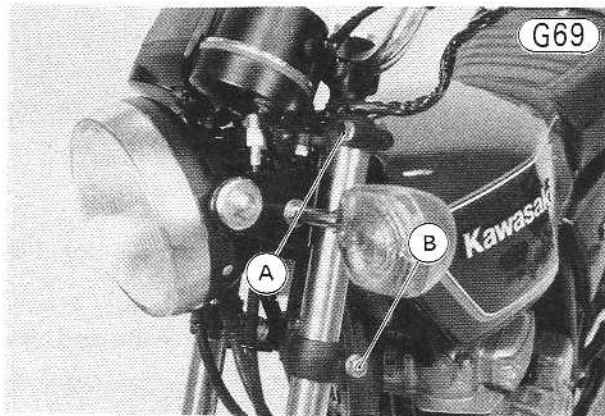

A. Upper Clamp Bolt B. Lower Clamp Bolt

- With a twisting motion, work the fork leg down and out.

Installation (each fork leg):

- Slide the fork leg up through the lower and upper clamps until the upper end of the fork tube is even with the upper surface of the stem head. Tighten the upper clamp bolt to 1.8 kg-m (13.0 ft-lbs) and the lower clamp bolt to 2.5 kg-m (18.0 ft-lbs).

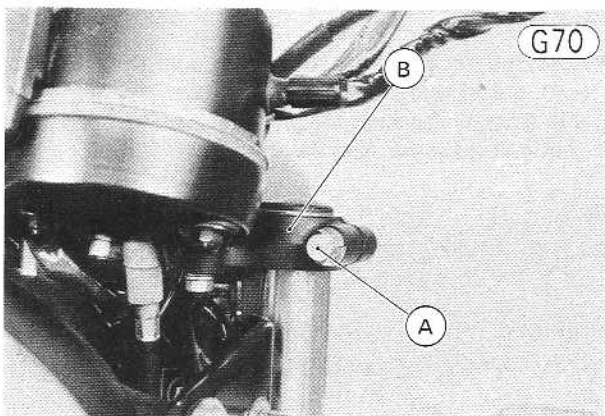

A. Upper Clamp Bolt B. Stem Head

- Install the fender between the fork legs.
- Install the caliper, tightening the caliper mounting bolts to 3.0 kg-m (22 ft-lbs) of torque. Each mounting bolt has a flat washer and lockwasher.
- Secure the lower brake hose in its guide. Be sure the rubber grommet is in place.
- Install the front wheel.

Disassembly:

- Remove the cap 15 from the inner tube.
- Press the top plug 17 to remove the top plug retaining ring 16, and remove the top plug, O ring 18, and spring

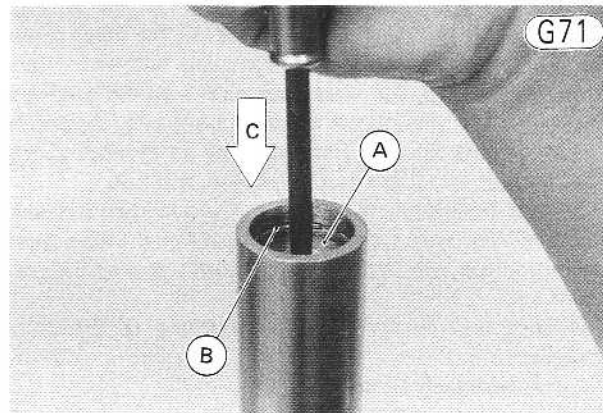

A. Top Plug C. Press down.
B. Retaining Ring

- Pour the oil into a suitable container, pumping as necessary to empty out all the oil.
- Using the front fork cylinder holder handle and holder adapter (special tools) to keep the cylinder from turning, unscrew the Allen bolt 11 and gasket 10 from the bottom of the outer tube 7 or 30, and then separate the inner tube from the outer tube by pulling it out.

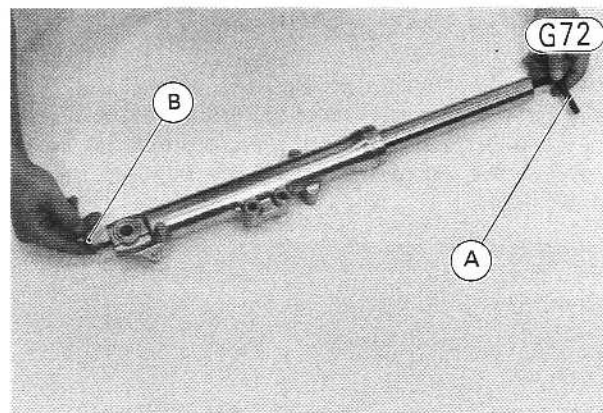

A. Front Fork Cylinder Holder Handle and Adapter (57001-183, 57001-1011)
B. Allen Wrench

- Remove the dust seal 13 from the outer tube 7.
- Slide or push the cylinder 2 and its spring 4 out the top of the inner tube.
- Remove the retainer 14 from the outer tube with a sharp hook, and pull out the oil seal 5. It may be necessary to heat the outer tube around the oil seal before pulling it out. Then pull the spacer 6 from the outer tube.

Front Fork

G73

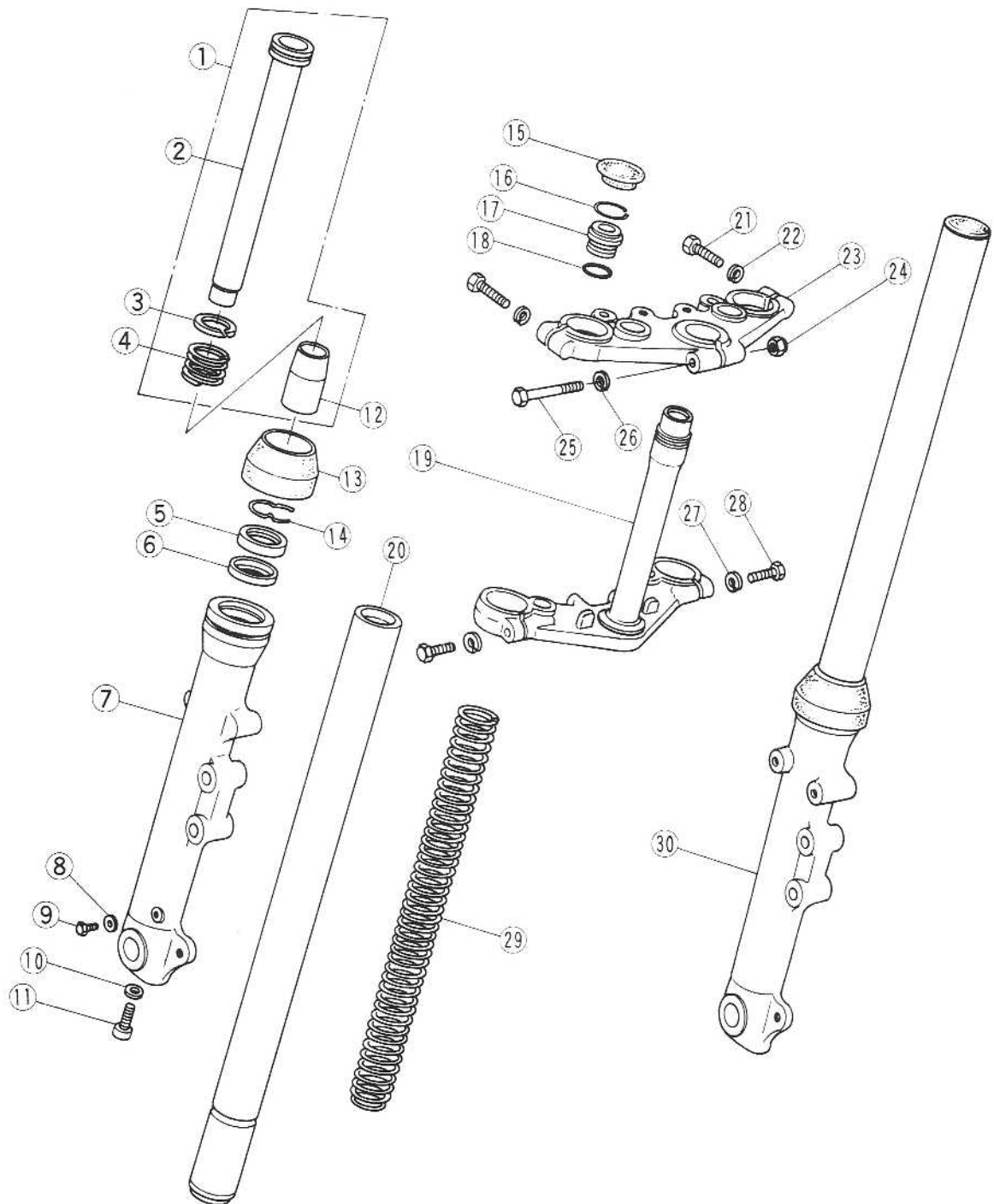

1. Cylinder and Piston Unit
2. Cylinder
3. Piston Ring
4. Spring
5. Oil Seal
6. Spacer
7. Outer Tube
8. Gasket

9. Drain Bolt
10. Gasket
11. Allen Bolt
12. Cylinder Base
13. Dust Seal
14. Retainer
15. Cap
16. Retaining Ring

17. Top Plug
18. O Ring
19. Steering Stem
20. Inner Tube
21. Bolt
22. Lockwasher
23. Stem Head
24. Nut

25. Bolt
26. Locknut
27. Locknut
28. Bolt
29. Spring
30. Fork Assy

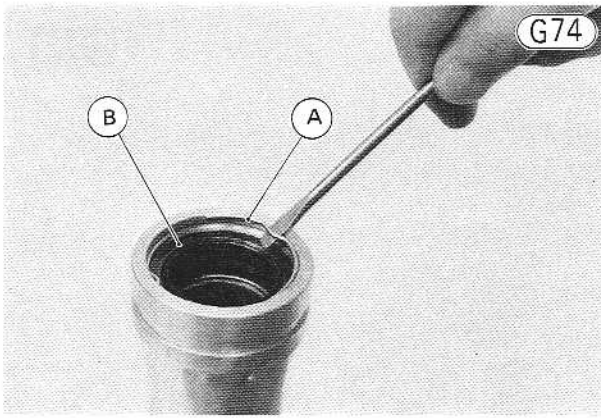

A. Retainer B. Oil Seal

Assembly Notes:

1. Apply liquid gasket to the gasket 10, apply a non-permanent locking agent to the Allen bolt, and tighten the bolt using the front fork cylinder holder handle and holder adapter (special tools). The torque for the Allen bolt is 1.8 kg-m (13.0 ft-lbs).
2. Replace the oil seal with a new one, apply oil to the outside, and install it with the front fork oil seal driver (special tool).

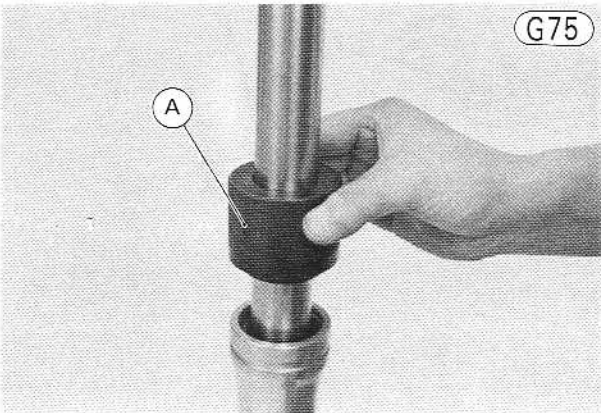

A. Front Fork Oil Seal Driver (57001-191)

3. Install the spring 29 with the smaller diameter end facing down.

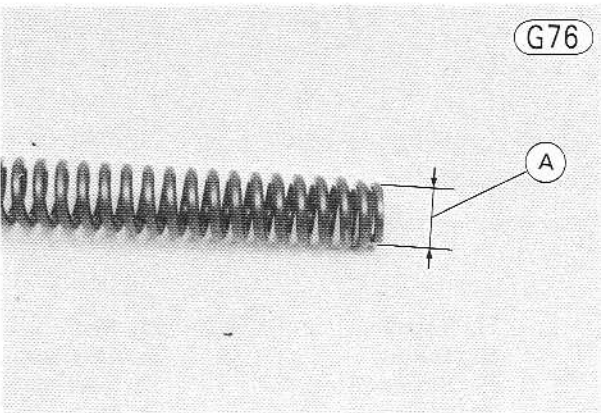

A. Smaller Diameter End

4. Fill the front fork with 150 cc of fresh SAE 5W20 oil.

Maintenance—Engine

Table of Contents

| | |
|--|-----|
| AIR CLEANER | 115 |
| CARBURETORS | 115 |
| Starter System | 116 |
| Pilot System | 117 |
| Main System | 117 |
| Float System..... | 118 |
| ROCKER ARMS, SHAFTS | 119 |
| CAMSHAFT | 119 |
| CAMSHAFT CHAIN, GUIDES, TENSIONER..... | 120 |
| CYLINDER HEAD, VALVES | 121 |
| Cylinder Head | 121 |
| Valve, Valve Guide, Valve Seat..... | 122 |
| Valve Installed Height..... | 125 |
| Valve Springs..... | 126 |
| Oil Seals | 126 |
| CYLINDER BLOCK, PISTONS | 127 |
| CRANKSHAFT, CONNECTING RODS..... | 130 |
| CLUTCH..... | 131 |
| TRANSMISSION | 133 |
| LUBRICATION | 135 |
| Engine Oil Pump..... | 135 |
| Oil Screen | 137 |
| Oil Filter..... | 137 |
| BALL, NEEDLE BEARINGS..... | 138 |
| OIL SEALS..... | 138 |

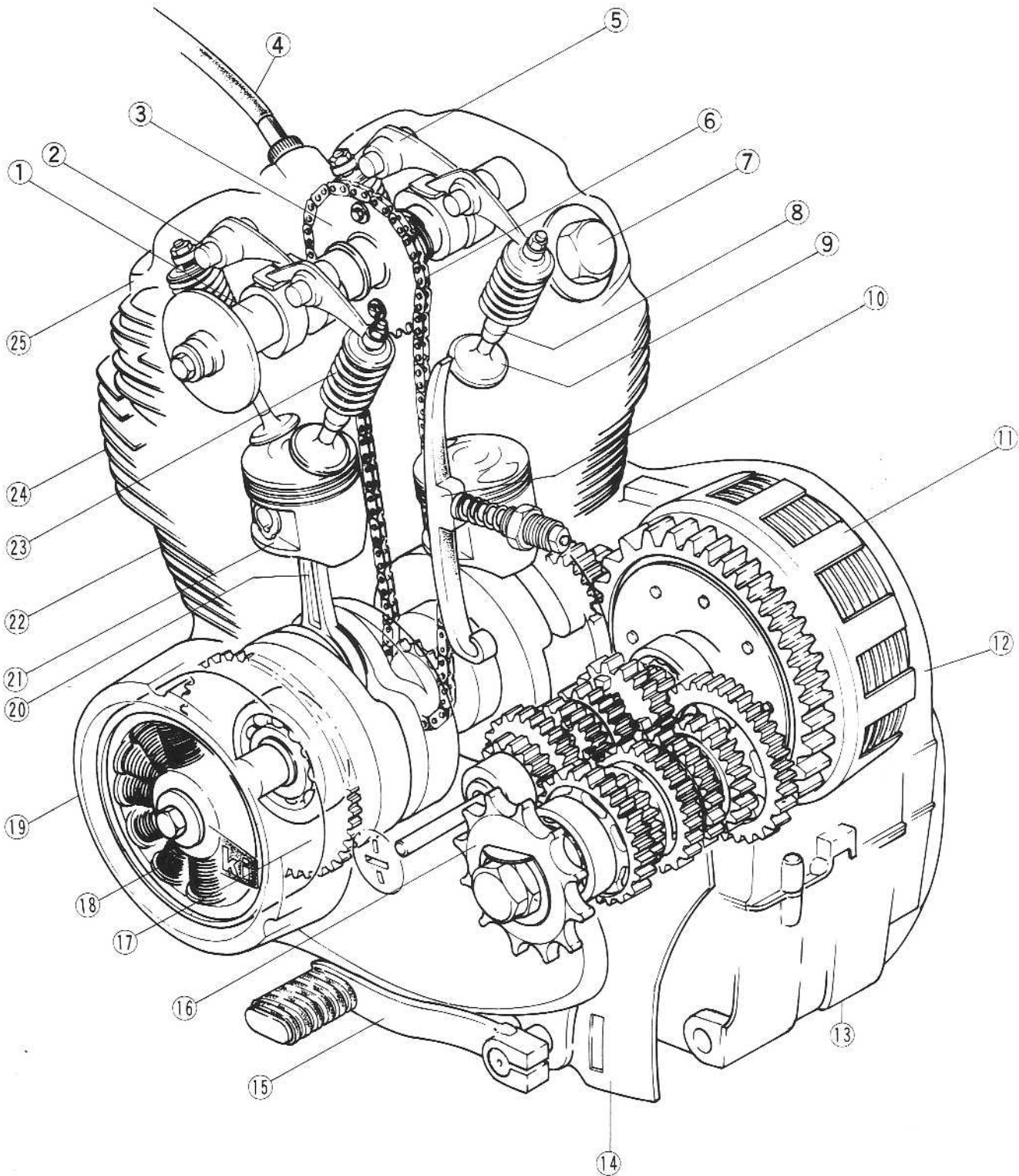

- | | | | |
|------------------------|---------------------------|------------------------|-------------------------|
| 1. Camshaft | 8. Valve Guide | 15. Shift Pedal | 22. Cylinder |
| 2. Rocker Arm Shaft | 9. Valve | 16. Engine Sprocket | 23. Valve Spring |
| 3. Camshaft Sprocket | 10. Pilot Screw Limiter | 17. Starter Drive Gear | 24. Cylinder Head |
| 4. Tachometer Cable | 11. Vacuum Plug | 18. Stator | 25. Cylinder Head Cover |
| 5. Rocker Arm | 12. Upper Crankcase Half | 19. Rotor | |
| 6. Camshaft Chain | 13. Lower Crankcase Half | 20. Connecting Rod | |
| 7. Valve Adjusting Cap | 14. Engine Sprocket Cover | 21. Piston | |

AIR CLEANER

Cleaning and replacement

The air cleaner element must be cleaned periodically (Pg. 10). In extremely dry, dusty areas, the element will need to be cleaned more often. After riding through rain or on muddy roads, the element should be cleaned immediately.

Remove the air cleaner element. Clean it in a bath of a high flash-point solvent, and then dry it from the inside using compressed air. Since this is a dry-type element, do not use kerosene or any fluid which would leave the element oily.

WARNING Clean the element in a well-ventilated area, and take care that there is no spark

or flame anywhere near the working area. Because of the danger of highly flammable liquids, do not use gasoline or low flash-point solvents to clean the element.

If the sponge gaskets on the sides of the element come loose, stick them back on with bond or other adhesive. If the sponge or the element is damaged or holed, replace the element.

Since repeated cleaning opens the pores of the element, replace it with a new one in accordance with the Periodic Maintenance Chart (Pg. 10). Also, if there is a break in the element material or any other damage to the element, replace the element with a new one.

CARBURETORS

Since the carburetor regulates and mixes fuel and air going to the engine, there are two general types of car-

H2

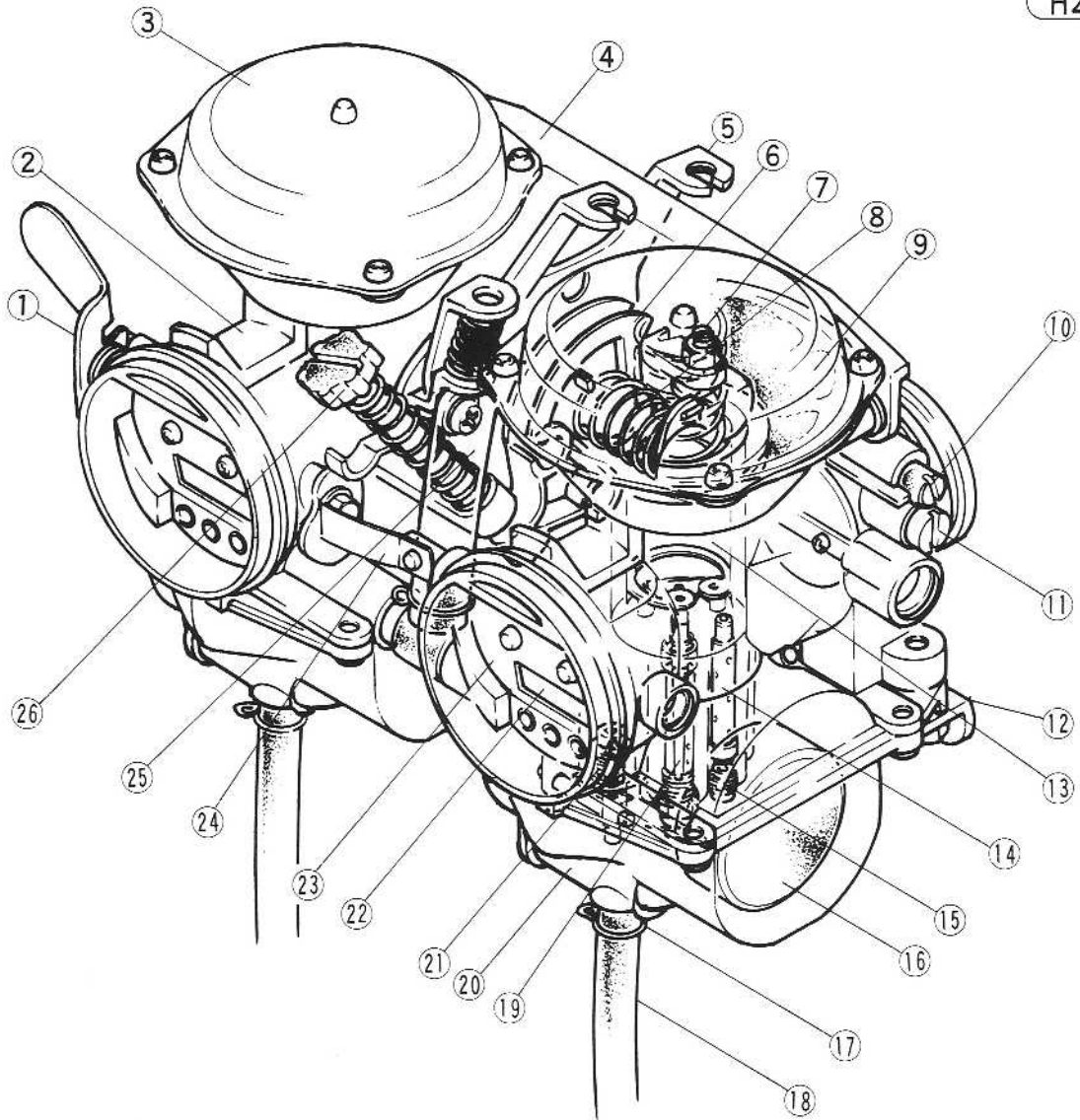

- | | | | |
|----------------------------|--------------------------|------------------------|--------------------------|
| 1. Choke Lever | 8. Spring | 15. Primary Main Jet | 22. Relief Valve |
| 2. Carburetor Body | 9. Diaphragm | 16. Float | 23. Choke Valve |
| 3. Upper Chamber Cover | 10. Pilot Screw Limiter | 17. Clip | 24. Choke Link Plate |
| 4. Upper Mounting Plate | 11. Vacuum Plug | 18. Overflow Tube | 25. Fuel Hose |
| 5. Cable Bracket | 12. Lower Mounting Plate | 19. Secondary Main Jet | 26. Idle Adjusting Screw |
| 6. Pulley | 13. Vacuum Piston | 20. Float Bowl | |
| 7. Balance Adjusting Screw | 14. Bleed Pipe | 21. Float Valve Needle | |

Carburetors

Table H1 Carburetor Specifications

| Type | Main Jet | | Air Jet | | | Pilot Jet | Pilot Screw | Fuel Level | |
|------|----------|---------------------|---------|--------------|----------------|-----------|-----------------|-------------|---------------|
| | Primary | Secondary | Pilot | Primary Main | Secondary Main | | | Design | Service |
| CV32 | 170 | Left 75 Right 80 | 130 | 150 | 60 | 38 | 1¼ turns out | 32~34 mm | 1.5~3.5 mm |

buretor trouble: too rich a mixture (too much fuel); or too lean a mixture (too little fuel). Such trouble can be caused by dirt, wear, maladjustment, or improper fuel level in the float chamber. A dirty or damaged air cleaner can also alter the fuel-to-air ratio.

Table H2 Mixture Trouble Symptoms

| Mixture too rich | Mixture too lean |
|---------------------------------|--|
| Engine is sluggish | Engine overheats |
| Smoky exhaust | Runs better with choke lever pulled up |
| Runs worse when warm | Spark plug burned white |
| Spark plug fouled black | Running is unstable |
| Runs better without air cleaner | Loss of power |

The following explanation of the functioning and maintenance of the carburetors covers the four main systems for fuel regulation and supply.

Table H3 Carburetor Systems

| System | Function |
|----------------|---|
| Starter System | Supplies the necessary rich mixture for starting a cold engine. |
| Pilot System | Supplies fuel at idling and low speeds. |
| Main System | Supplies fuel at medium and high speeds. |
| Float System | Maintains the fuel at a constant level in the float chamber. |

- CAUTION** 1. Remove the diaphragm and float before cleaning the carburetor with compressed air, or they will be damaged.
2. Remove as many rubber or plastic parts from the carburetors (Table H4) as possible before cleaning the carburetors with a cleaning solution. This will prevent damage or deterioration of the parts.
3. The carburetor body has plastic parts (Table H4) that cannot be removed. DO NOT use a strong carburetor cleaning solution which could attack these parts; instead, use a mild cleaning solution safe for plastic parts.

4. Do not use wire for cleaning as this could damage the jets.

Table H4 Carburetor Rubber Parts and Plastic Parts

| Parts | Quantity | Removable |
|------------------------|----------|-----------|
| Breather Tubes | 2 | Yes |
| Floats | 2 | Yes |
| Float Bowl O Rings | 2 | Yes |
| Fuel Hose | 1 | Yes |
| Idle Adjusting Screw | 1 | Yes |
| Idle Limiter | 2 | Yes |
| Jet Needle Holder | 2 | Yes |
| Overflow Tubes | 2 | Yes |
| Pilot Screw O Rings | 2 | Yes |
| Pilot Jet Rubber Plugs | 2 | Yes |
| 3-way Joint O Rings | 4 | Yes |
| Vacuum Pistons | 2 | Yes |

Starter System

In order for the starter system to work properly, the choke lever must be pushed up fully so that the choke valve will be kept closed and sufficient vacuum can be built up at the engine of the carburetor bore. Clogged pilot jet, main jets, pilot air jet, needle jet holder and main jet bleed pipe will cause insufficient atomization, thus impairing starter efficiency. Fuel mixture trouble results if choke lever link mechanism, pilot and main system is defective. A damaged relief valve will cause insufficient vacuum, thus impairing starter system efficiency. Fuel mixture trouble results if the choke valve does not open fully after the choke lever is returned.

Cleaning and inspection

Disassemble the carburetor, and wash the main jets, pilot jet, needle jet holder, main jet bleed pipe, air jets, and air passage with a high flash-point solvent, blowing them clean with compressed air. If necessary, use a bath of automotive type carburetor cleaner.

Pull up and push down the choke lever to check that the choke valves move smoothly. The choke valves must close the carburetor bores completely when the lever is pulled up, and must open fully when the lever is pushed down. If necessary, adjust the choke linkage (Pg. 42). To check that the relief valve spring is working properly, push on the relief valve itself. The relief valve must move smoothly, and must close by spring tension.

If the choke valve or the relief valve does not work properly, replace the carburetor body.

Starter System

H3

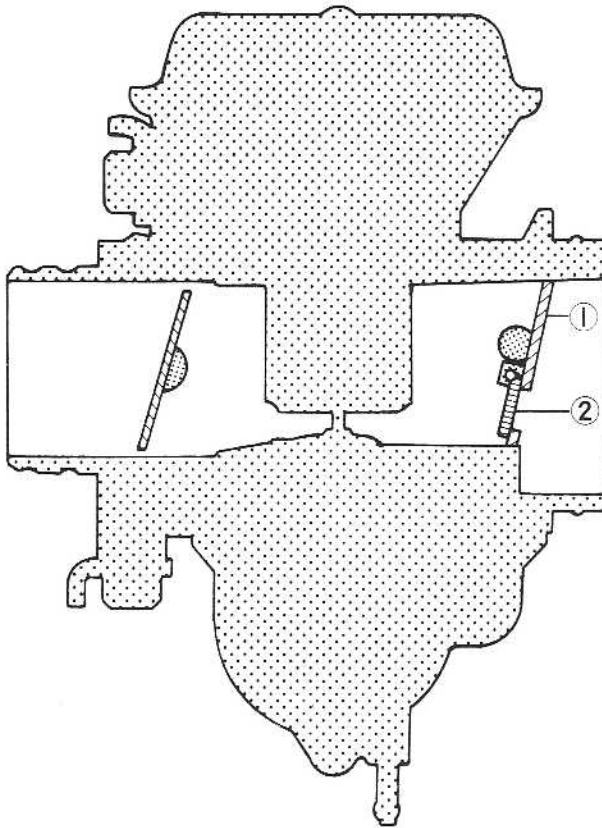

- 1. Choke Valve
- 2. Relief Valve

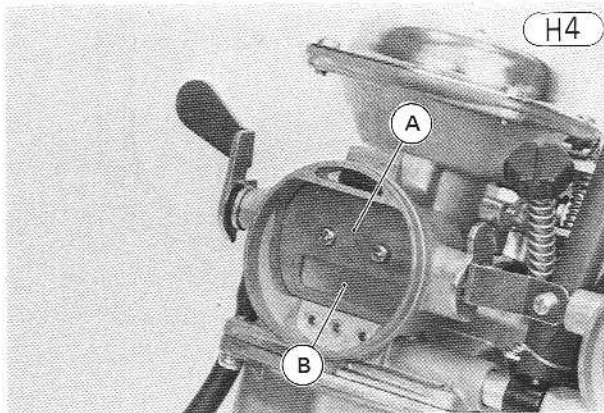

- A. Choke Valve
- B. Relief Valve

Pilot System

Cleaning and replacement

Disassemble the carburetor, and wash the primary main jet, pilot jet, pilot air jet, and air passage with a high flash-point solvent, blowing them clean with compressed air. If necessary, use a bath of automotive type carburetor cleaner.

Remove the pilot screw, and check that the tapered portion is not worn or otherwise deformed. If it is, replace the screw. If the screw O ring is damaged, replace the O ring.

Pilot System

H5

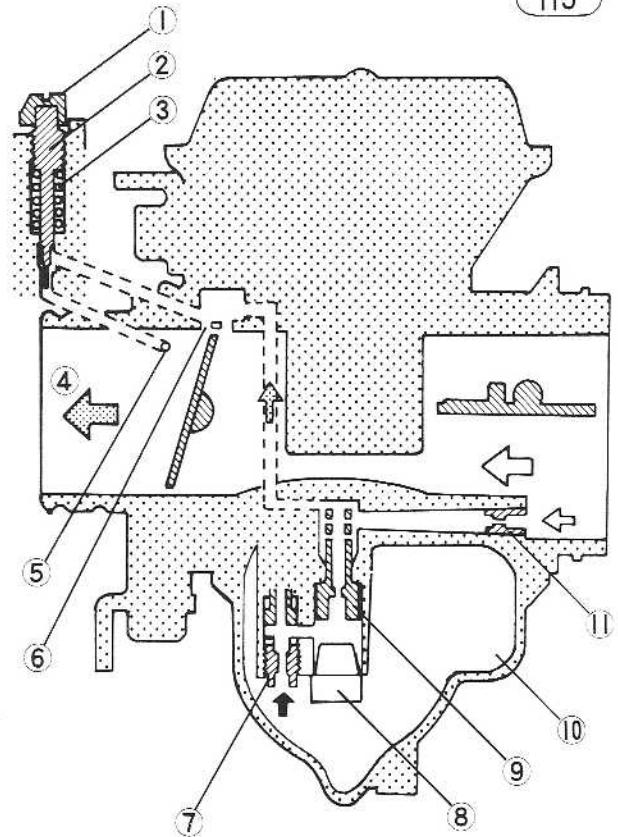

- 1. Pilot Screw Limiter
- 2. Pilot Screw
- 3. Spring
- 4. Carburetor Bore
- 5. Pilot Outlet
- 6. Bypass Outlet
- 7. Primary Main jet
- 8. Plug
- 9. Pilot Jet
- 10. Float Chamber
- 11. Pilot Air Jet

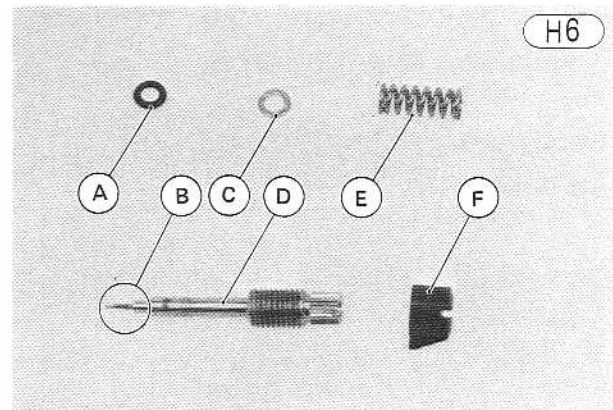

- A. "O" Ring
- B. Tapered Portion
- C. Washer
- D. Pilot Screw
- E. Spring
- F. Pilot Screw Limiter

Main System

Cleaning and adjustment

Disassemble the carburetor, and wash the vacuum piston, main jets, main jet bleed pipe, main jet holder, needle jet, jet needle, main air jets, and air passage with a high flash-point solvent, blowing them clean with compressed air. If necessary, use a bath of automotive type carburetor cleaner.

118 MAINTENANCE—ENGINE

Visually inspect the diaphragm. If there is any tear or other damage, the diaphragm should be replaced.

Main System

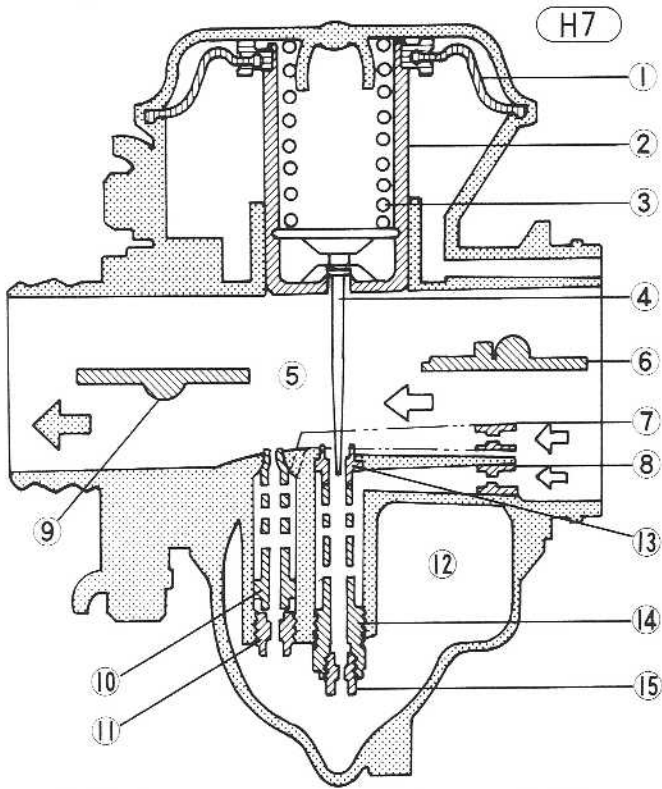

- | | |
|---------------------------|------------------------|
| 1. Diaphragm | 9. Butterfly Valve |
| 2. Vacuum Piston | 10. Bleed Pipe |
| 3. Spring | 11. Primary Main Jet |
| 4. Jet Needle | 12. Float Chamber |
| 5. Carburetor Bore | 13. Needle Jet |
| 6. Choke Valve | 14. Needle Jet Holder |
| 7. Primary Main Air Jet | 15. Secondary Main Jet |
| 8. Secondary Main Air Jet | |

Float System

Float System

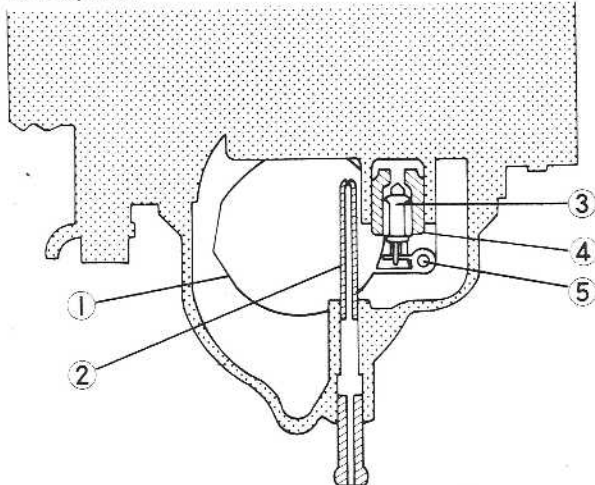

- | | |
|------------------|---------------|
| 1. Float | 4. Valve Seat |
| 2. Overflow Pipe | 5. Float Pin |
| 3. Valve Needle | |

Service fuel level/measurement and adjustment

Install the fuel level gauge (special tool) onto the overflow tube.

Secure the motorcycle in a true vertical position. Turn the fuel tap to the "ON" or "RES" position, and loosen the drain on the bottom of the float bowl. Hold the plastic tube against the side of the carburetor so that the "0" line is even with the bottom edge of the carburetor body. Read the service fuel level in the gauge.

NOTE: Measure the service fuel level at the center of the carburetor.

Service Fuel Level Measurement

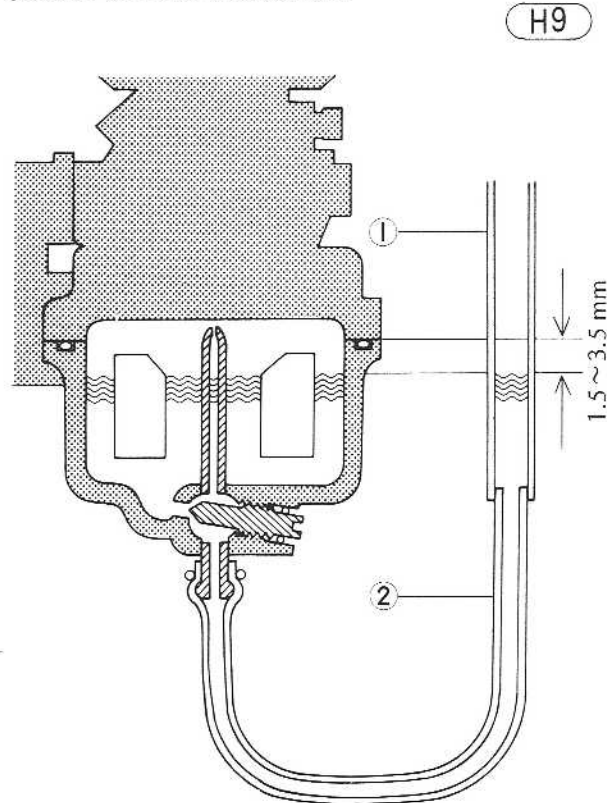

- | |
|-------------------------------------|
| 1. Fuel Level Gauge (57001-1017) |
| 2. Overflow Tube |

Table H5 Service Fuel Level

| Standard |
|--|
| 1.5 ~ 3.5 mm below from the bottom edge of the carburetor body to the fuel level |

If the fuel level is incorrect, remove the float bowl and float. Bend the tang on the float a very slight amount to change the fuel level. Bending it up toward the valve closes the valve sooner and lowers the fuel level; bending it down raises the level.

After adjustment, measure the service fuel level again, and readjust if necessary.

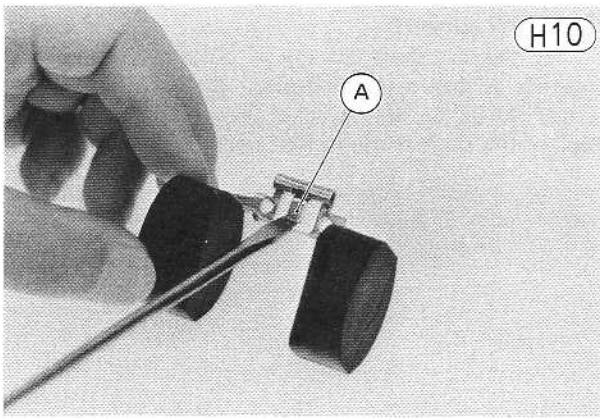

A. Tang

NOTE: Service fuel level is defined as the vertical distance from the bottom edge of the carburetor body to the surface of the fuel in the float chamber.

Cleaning and replacement

If dirt gets between the valve needle and the seat, the valve needle will not close and fuel will overflow. Overflow can also result if the needle and seat become worn. If the needle sticks closed, no fuel will flow into the carburetor.

Remove the carburetor, and take off the float bowl and float. Wash the bowl and float parts in a high flash-point solvent. Use carburetor cleaner if necessary to wash the float bowl and metal parts. Blow out the fuel overflow pipe with compressed air.

Examine the float, and replace if damaged. If the needle is worn as shown in the diagram, replace the needle and seat as a set.

Valve Needle

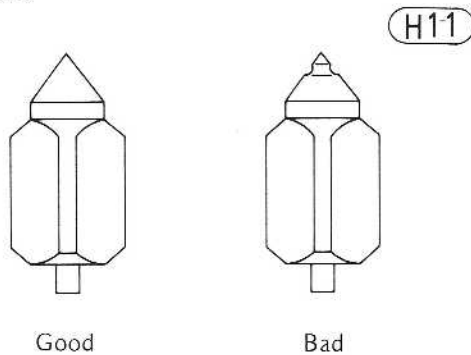

ROCKER ARMS, SHAFTS

Rocker arm/shaft wear

Visually inspect where the cam and valve stem wear on each arm. If there is any damage or uneven wear, replace the arm.

Measure the inside diameter of each arm with a cylinder gauge. If it exceeds the service limit, replace the arm.

Measure the diameter of each shaft where the arm fits. If the diameter is less than the service limit, replace the shaft.

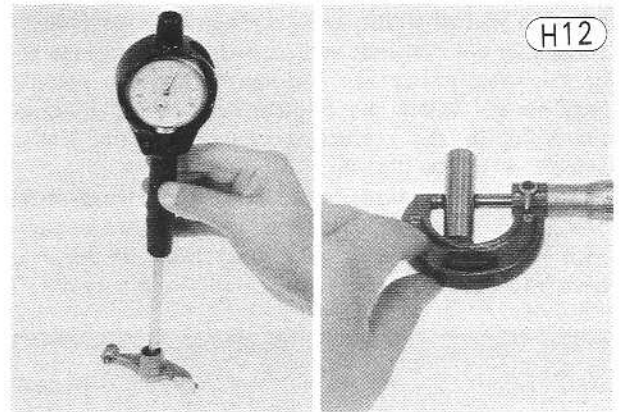

Table H6 Rocker Arm Inside Diameter

| Standard | Service Limit |
|------------------|---------------|
| 13.000~13.018 mm | 13.05 mm |

Table H7 Rocker Shaft Diameter

| Standard | Service Limit |
|------------------|---------------|
| 12.976~12.994 mm | 12.95 mm |

CAMSHAFT

Cam wear

Remove the camshaft, and measure the height of each cam with a micrometer. If the cams are worn down past the service limit, replace the camshaft.

Cam Height Measurement

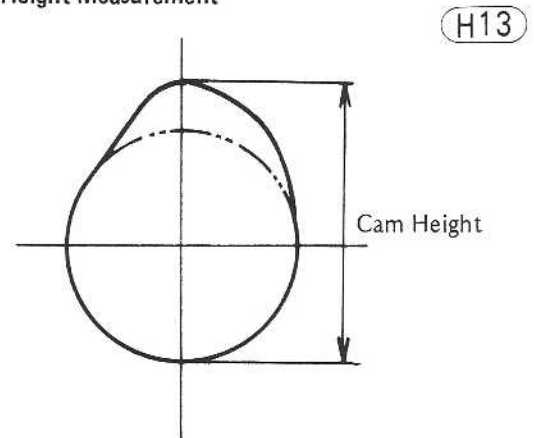

Table H8 Cam Height

| | Standard | Service Limit |
|---------|------------------|---------------|
| Inlet | 40.201~40.341 mm | 40.110 mm |
| Exhaust | 39.831~39.971 mm | 39.740 mm |

120 MAINTENANCE—ENGINE

Journal wear

The journal wear is measured using a plastigauge (press gauge), which is inserted into the clearance to be measured. The plastigauge indicates the wear by the amount it is compressed and widened when the parts are assembled.

Remove the cylinder head cover, cut strips of plastigauge to journal width, and place a strip on each journal parallel to the camshaft and so that the plastigauge will be compressed between the journal and the cylinder head cover. Install the cylinder head cover, tightening the bolts in the correct sequence with the correct amount of torque (Pg. 46).

Remove the cylinder head cover, and measure the plastigauge width to determine the clearance between each journal and the cylinder head cover. If the clearance exceeds the service limit, replace the camshaft.

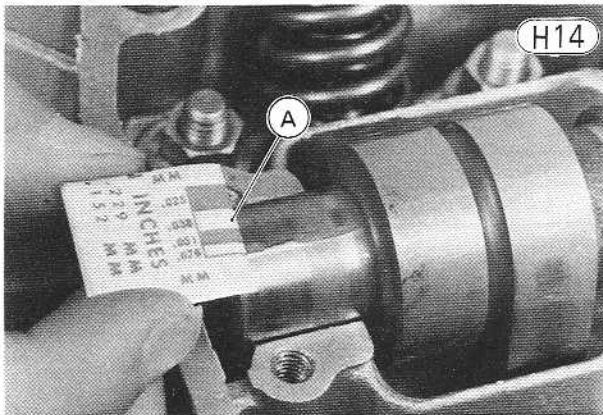

A. Plastigauge

Table H9 Camshaft Journal/Cylinder Head Cover Clearance

| Standard | Service Limit |
|----------------|---------------|
| 0.030~0.070 mm | 0.19 mm |

Measure the diameter of each camshaft journal with a micrometer. If a diameter of any journal is less than the service limit, replace the camshaft.

Camshaft Journal Diameter Measurement

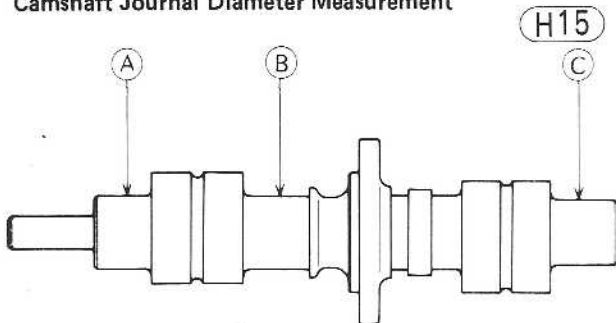

Table H10 Camshaft Journal Diameter

| | Standard | Service Limit |
|------|------------------|---------------|
| A, B | 24.950~24.970 mm | 24.90 mm |
| C | 21.950~21.970 mm | 21.90 mm |

Camshaft runout

Set the camshaft on the V blocks at the outside journals as shown in the figure. Measure runout with a dial gauge at the sprocket mounting location, and replace the shaft if the runout exceeds the service limit.

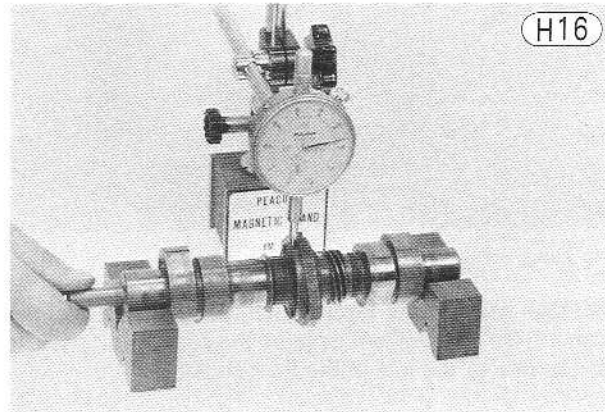

Table H11 Camshaft Runout

| Standard | Service Limit |
|---------------|---------------|
| under 0.01 mm | 0.1 mm |

CAMSHAFT CHAIN, GUIDES, TENSIONER

Camshaft chain wear

Remove the camshaft chain, hold the chain taut with a force of about 5 kg in some manner such as the one shown in Fig. H17, and measure a 20-link length. If the chain has lengthened beyond the service limit, replace it with a new one.

Camshaft Chain Length Measurement

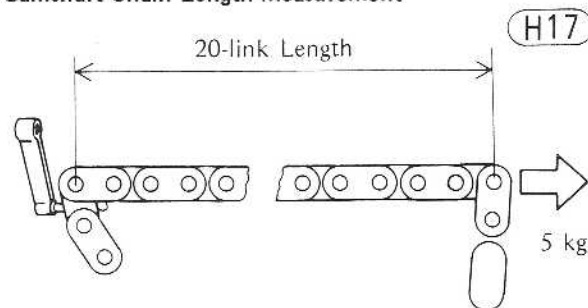

Table H12 Camshaft Chain 20-link Length

| Standard | Service Limit |
|----------------|---------------|
| 155.5~155.6 mm | 158.0 mm |

Chain guide wear

Remove the chain guides, and inspect them visually. Replace a guide if the rubber or any other portion is damaged.

Measure the depth of the grooves where the chain links run. Replace a guide if the wear exceeds the service limit.

Chain Guide Rubber Wear

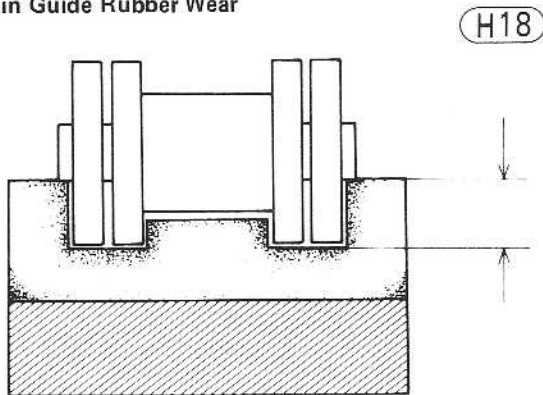

Table H13 Camshaft Chain Guide Wear

| | Service Limit |
|-------|---------------|
| Front | 1.4 mm |
| Rear | 2.3 mm |

Chain tensioner inspection

Remove the camshaft chain tensioner. Visually inspect the push rod, and check that it moves smoothly in the guide, with the spring removed. If there is any damage or abnormal operation, replace the tensioner with a new one.

Measure the spring free length. Replace the spring if the free length exceeds the service limit.

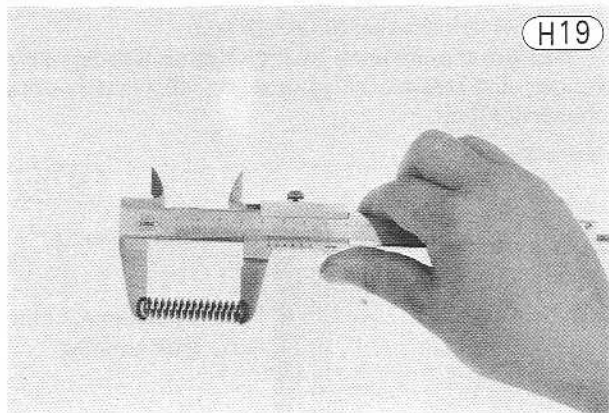

Table H14 Chain Tensioner Spring Free Length

| Standard | Service Limit |
|---------------|---------------|
| about 44.2 mm | 42 mm |

CYLINDER HEAD, VALVES

Cylinder Head

Cleaning and inspection

Remove the cylinder head (Pg. 48) and valves (Pg. 50). Scrape out any carbon, and wash the head with a high flash-point solvent.

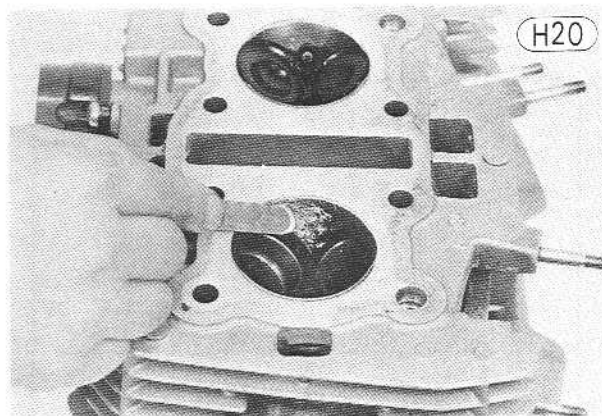

Cylinder head warp

Lay a straightedge across the lower surface of the head at several different points, and measure warp by inserting a thickness gauge between the straightedge and the head. If warp exceeds the service limit, repair the mating surface. Replace the cylinder head if the mating surface is badly damaged.

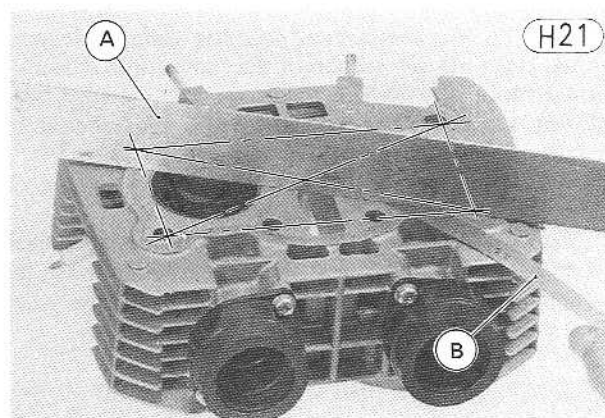

A. Straightedge

B. Thickness Gauge

Table H15 Cylinder Head Warp

| Service Limit |
|---------------|
| under 0.05 mm |

Combustion chamber volume measurement

The combustion chamber volume should be measured any time that compression measurement results in compression pressures well below or above the standard.

NOTES:

1. Another person will be needed to help expel air bubbles out of the combustion chamber.
2. Prepare a piece of transparent plastic plate which has a flat surface and two holes about 35 mm apart in its center portion. One hole should be about 6 mm in diameter, the other about 3 mm in diameter. The plate must be oil-resistant, about 120 mm square, and at least 3 mm thick.

122 MAINTENANCE—ENGINE

Plastic Measuring Plate

H22

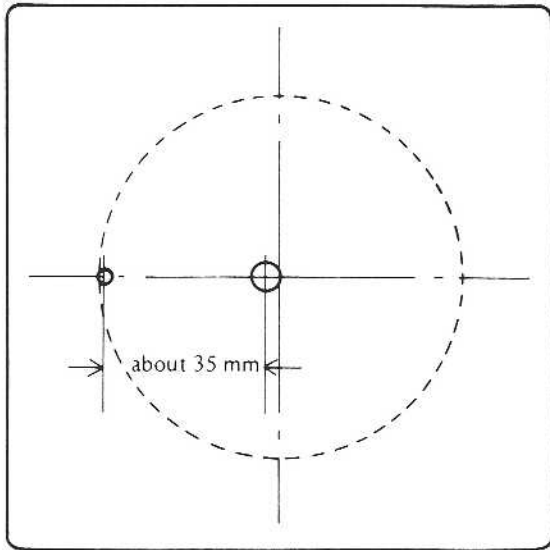

- Obtain a burette or syringe which is calibrated at one-cc or smaller graduations. Fill it with oil.

Prior to the combustion chamber volume measurement, clean off any carbon in the combustion chamber, and remove any gasket flakes on the cylinder head mating surface. The standard spark plug should be installed in the chamber to be measured.

NOTE: The valves must seat well to prevent the oil from leaking out.

Apply a thin coat of grease to the cylinder head mating surface and place the plastic plate over the cylinder head combustion chamber, fitting its small hole near the edge of the combustion chamber.

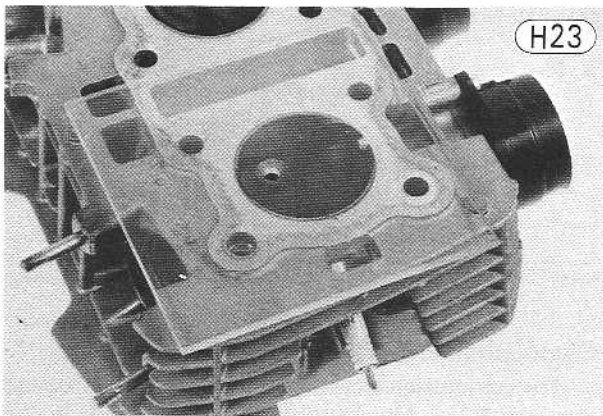

H23

Place the cylinder head on a level surface. Through the large hole, fill the combustion chamber with light oil such as 2-stroke oil until the chamber is completely but not overly filled. Tilt the cylinder head slightly so that air bubbles come out through the small hole. The oil should just rise to the bottom edge of the holes in the plate.

The amount of oil used to fill the chamber is the combustion chamber volume.

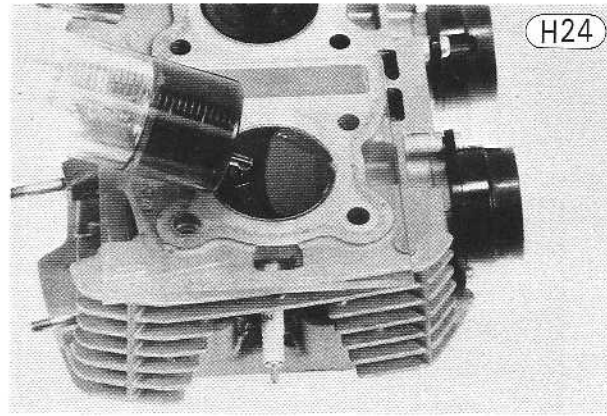

H24

Table H16 Combustion Chamber Volume

| Standard |
|--------------|
| 17.5~18.3 cc |

If the combustion chamber volume is too small, it is possible that the cylinder head was modified for higher compression. Make sure that all carbon deposits have been cleaned out of the chamber.

If the combustion chamber volume is too large, it is possible that the valves and valve seats have been resurfaced so much that the volume is increased. Make sure that the spark plug is the standard type and that it is fully tightened.

Valve, Valve Guide, Valve Seat

Valve inspection

Visually inspect the valve face, and replace the valve if it shows deformation or uneven wear.

Measure the thickness of the valve head using vernier caliper, and replace the valve if the thickness is under the service limit.

Valve Shape

H25

Do not grind off more than 0.2 mm.

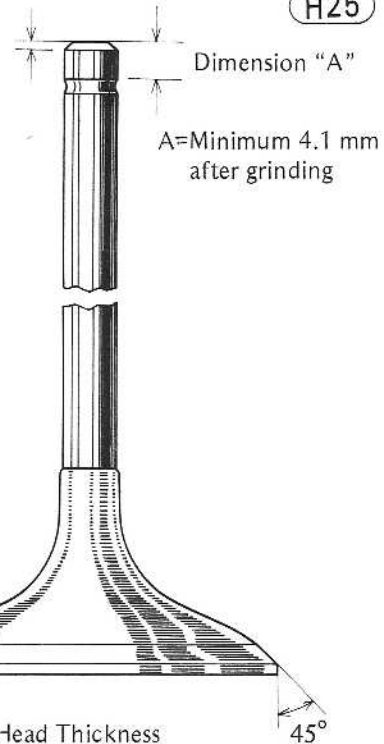

Table H17 Valve Head Thickness

| | Standard | Service Limit |
|----|--------------|---------------|
| IN | 0.55~0.85 mm | 0.4 mm |
| EX | 0.85~1.15 mm | 0.5 mm |

If the seating surface of the valve or the end of the valve stem is damaged or badly worn, repair the valve with a valve refacer. The angle of the seating surface is 45° (Fig. H25).

CAUTION If the valve stem is ground down, be sure to leave at least 4.1 mm of stem end above the wide groove portion.

Valve Stem Grinding

(H26)

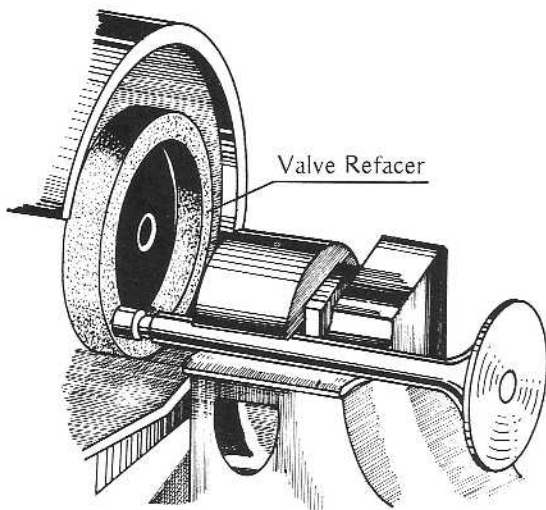

Position the valve in V blocks at each end of the straight portion of the stem, and set dial gauge against the center of the stem. See the example shown in Fig. H27.

Turning the valve, read the variation in the dial gauge. Replace the valve if it is bent more than the service limit.

Valve Stem Bend

(H27)

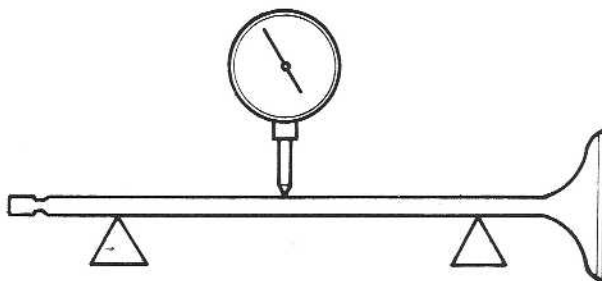
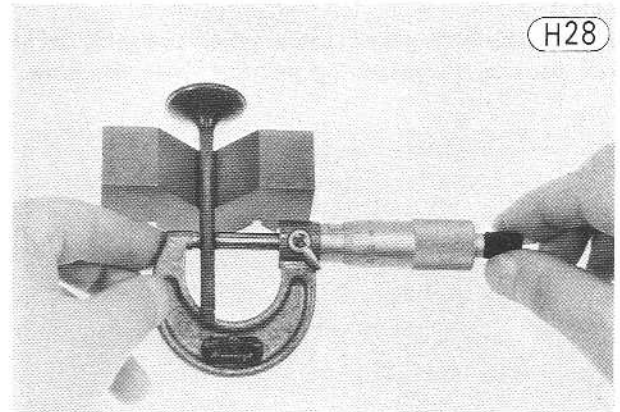

Table H18 Valve Stem Bend

| Standard | Service Limit |
|---------------|---------------|
| under 0.01 mm | 0.05 mm |

Measure the diameter of the valve stem with a micrometer. Since the stem wears unevenly, take measurements at four places up and down the stem, keeping the micrometer at right angles to the stem.

Replace the valve if the stem is worn to less than the service limit.



(H28)

Table H19 Valve Stem Diameter

| | Standard | Service Limit |
|---------|----------------|---------------|
| Inlet | 5.495~5.510 mm | 5.44 mm |
| Exhaust | 5.480~5.495 mm | 5.42 mm |

Valve guide inspection

Remove the valve, and measure the inside diameter of the valve guide using a small bore gauge and micrometer. Since the guide wears unevenly, measure the diameter at four places up and down the guide. If any measurement exceeds the service limit, replace the guide.

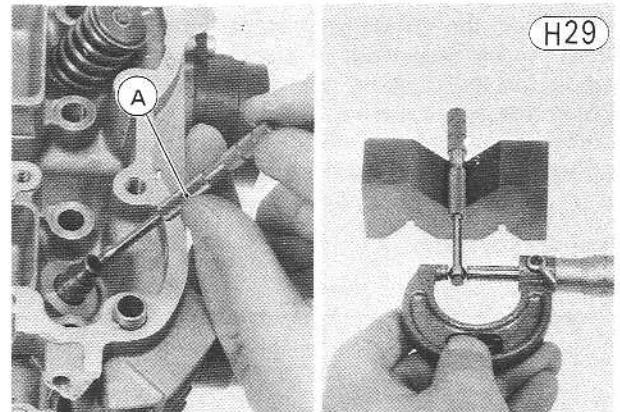

(H29)

A. Bore Gauge

Table H20 Valve Guide Inside Diameter

| Standard | Service Limit |
|----------------|---------------|
| 5.520~5.532 mm | 5.6 mm |

If a small bore gauge is not available, inspect the valve guide wear by measuring the valve to valve guide clearance with the wobble method, as indicated below.

124 MAINTENANCE—ENGINE

Insert a new valve into the guide and set a dial gauge against the stem perpendicular to it as close as possible to the cylinder head mating surface. Move the stem back and forth to measure valve/valve guide clearance. Repeat the measurement in a direction at a right angle to the first.

If the reading exceeds the service limit, replace the guide.

NOTE: The reading is not actual valve/valve guide clearance because the measuring point is above the guide.

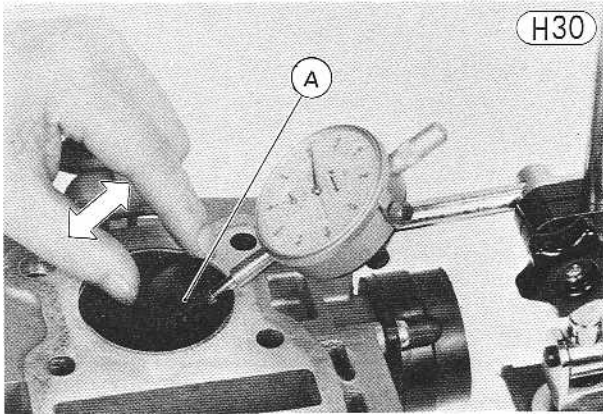

A. Valve

Table H21 Valve/Valve Guide Clearance (Wobble Method)

| Standard | Service Limit |
|----------------|---------------|
| 0.024~0.089 mm | 0.24 mm |

Valve seat repair

The valve must seat in the valve seat evenly around the circumference over the specified area. If the seat is too wide, the seating pressure per unit or area is reduced, which may result in compression leakage and carbon accumulation on the seating surface. If the seating area is too narrow, heat transfer from the valve is reduced and the valve will overheat and warp. Uneven seating or seat damage will cause compression leakage.

Valve Seating Width

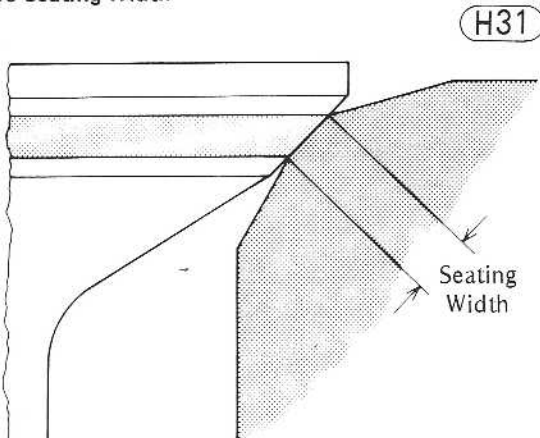
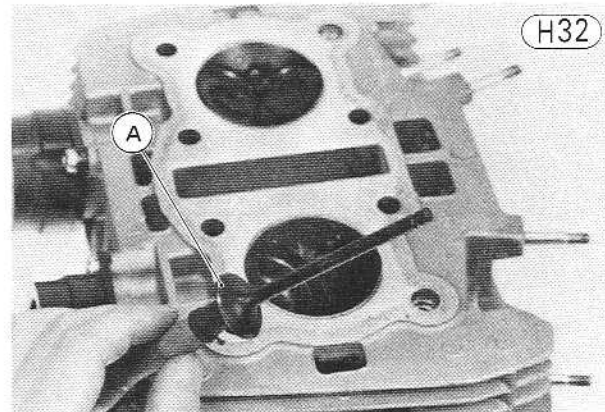

Table H22 Valve Seating Width

| Standard |
|--------------|
| 0.35~0.65 mm |

To determine whether or not the valve seat requires repair, first remove the valve, apply machinist's dye to the valve seat, and then use a lapper to tap the valve lightly into place. Remove the valve, and note where the dye adheres to the valve seating surface. The valve seating surface should be in the middle of the valve face (Fig. H31). The distribution of the dye on the seating surface gives an indication of seat condition (Fig. H34). **NOTE:** The valve and valve guide must be in good condition before this check will give an accurate indication of valve seat condition.



A. Valve Seating Surface

A valve seat which requires repair is cut with a set of valve seat cutters.

First, cut the seating surface of the valve seat with the 45° cutter. Cut only the amount necessary to make a good surface; overcutting will reduce the valve clearance, possibly making it no longer adjustable.

Next, use the 75° cutter to cut the surface outside the seating surface. Cut these two surfaces so that the seating surface will have the specified width.

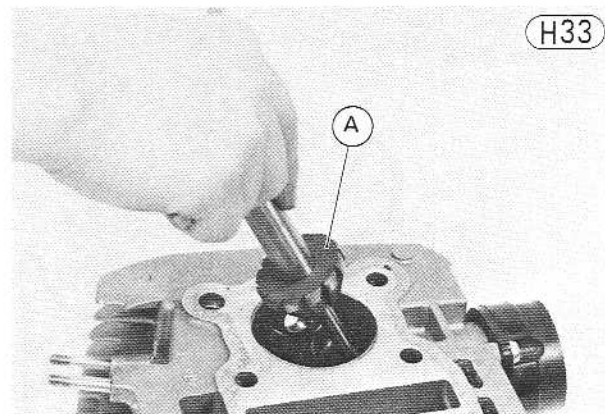

A. Valve Cutter

After cutting, lap the valve to properly match the valve and valve seat surfaces. Start off with coarse lapping compound, and finish with fine compound.

Valve/Valve Seat Contact Area

H34

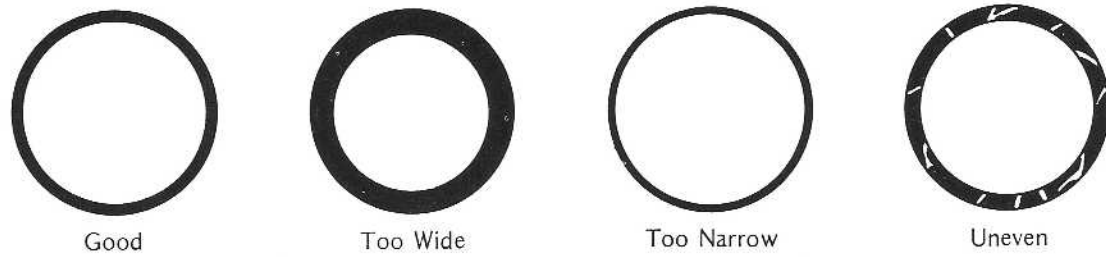

Cutting Angle of Valve Seat

H35

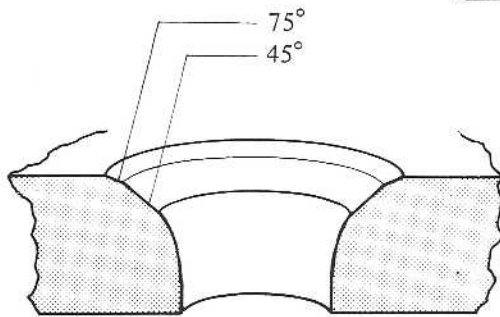

Apply compound to the valve seat, and tap the valve lightly into place while rotating it with a lapper, repeating this until a smooth, matched surface is obtained.

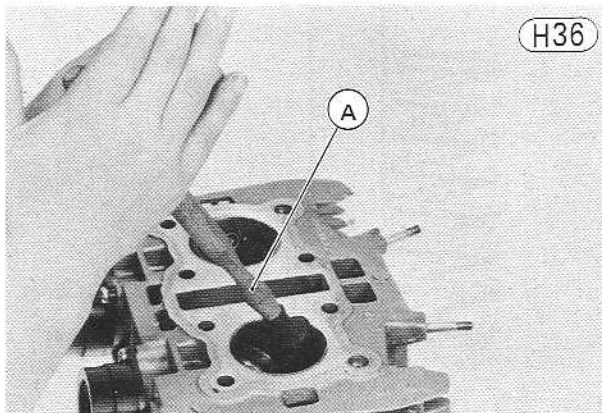

H36

A. Lapper

When lapping is completed, be sure to mark each valve so it will be properly matched to its corresponding valve seat during assembly.

Valve Installed Height

The valve clearance adjusting screw, installed in the rocker arm, is used to adjust the valve clearance. There is, however, a limit to the amount of adjustment possible turning the adjusting screw. Resurfacing of the valve

face and valve seat inevitably drops the valve deeper into the valve seat, allowing the valve stem end to come closer to the adjusting screw. Consequently, the adjusting screw must be turned out to compensate for the reduced valve clearance. If the valve seat, face, and/or stem end are resurfaced, measure the installed valve height from the cylinder head upper surface which the valve guide contacts with to the end of the valve stem with a vernier caliper before assembling the cylinder head. Refer to Table H23 for the recommended repair.

Over a period of long use and repeated resurfacing, the valve may drop so far into the valve seat that even the adjusting screw cannot give adequate clearance. In this case, it is possible to grind the end of the valve stem to reduce the valve installed height and so gain the needed clearance (See Caution in Pg. 123).

If the valve drops so far into the valve seat that the installed height becomes quite large, either by a resurfacing error or heavy wear, it may be necessary to replace the valve and remeasure the installed height. If this is not successful, it will be necessary to replace the cylinder head. Replacement valve seats are not available.

Valve Stem Height

H37

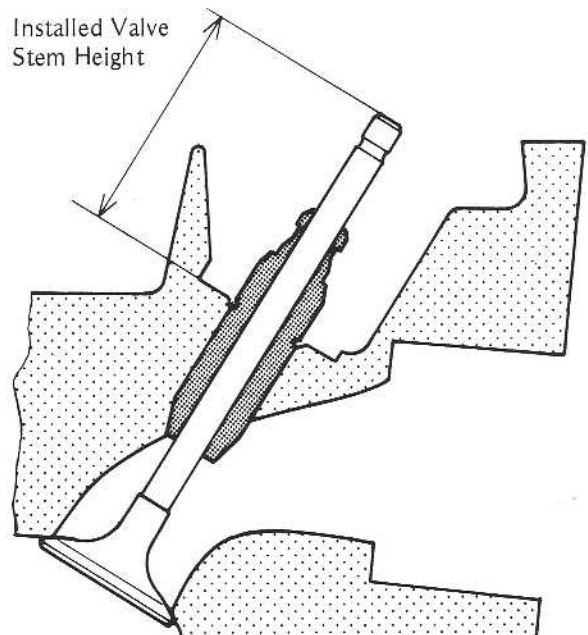

126 MAINTENANCE—ENGINE

Table H23 Valve Installed Height

| MEASUREMENT | PROBABLE CAUSE | RECOMMENDATION |
|--------------------|--|--|
| Less than 37.34 mm | Valve stem previously ground | <ol style="list-style-type: none"> 1. Move valve to deeper cut seat. Remeasure. 2. Grind valve face to drop it farther into seat. Remeasure. 3. Replace valve. Remeasure. |
| 37.35~38.52 mm | Normal acceptable | |
| 38.53~38.72 mm | Wear or valve face and seat grinding have dropped valve too far into seat. | <ol style="list-style-type: none"> 1. Move valve to shallower cut seat. Remeasure. 2. Grind 0.2 mm maximum off valve stem. See CAUTION, Pg. 123. Remeasure. |
| More than 38.73 mm | Valve face or seat worn out or ground excessively. | <ol style="list-style-type: none"> 1. Replace valve. Remeasure. 2. Replace cylinder head. Remeasure. |

Valve Springs

Spring tension

Remove the springs, and set them one at a time, on a spring tension testing device. Compress the spring, and read the tension at the test length. If the spring tension at the specified length is weaker than the service limit, replace the spring.

Valve Spring Tension Measurement

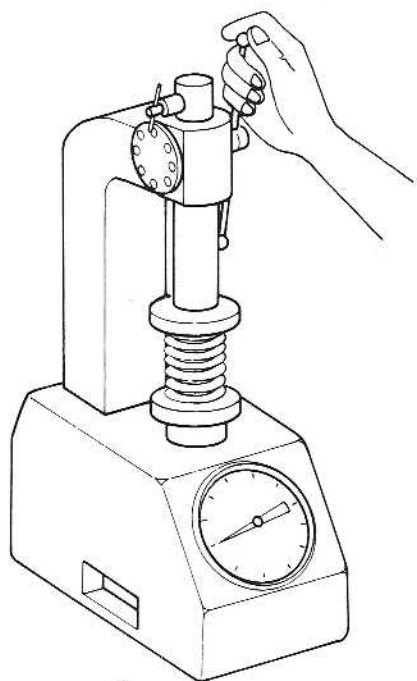

H38

Squareness

Measure the squareness of each spring by standing each end on a surface plate and setting a square against it. Replace any spring for which the distance between the top of the spring and the square is greater than the service limit.

Valve Spring Squareness

H39

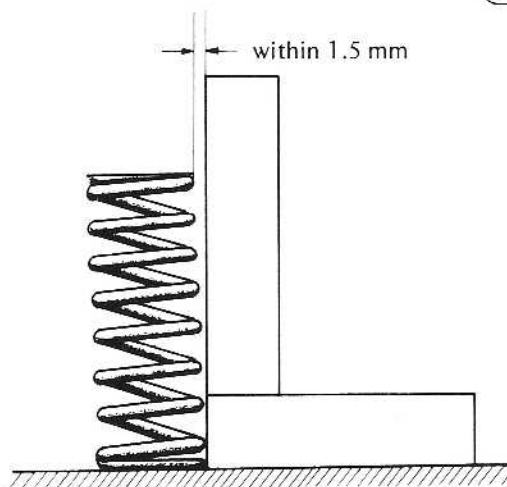

Table H25 Valve Spring Squareness

| Standard | Service Limit |
|--------------|---------------|
| under 1.0 mm | 1.5 mm |

Table H24 Valve Spring Tension

| | Length | Standard | Service Limit |
|-------|---------|--------------|---------------|
| Inner | 25.2 mm | 29.1~33.9 kg | 19.7 kg |
| Outer | 27.2 mm | 51.5~60.5 kg | 36.4 kg |

Oil Seals

The oil seal around each valve stem prevents oil from leaking down into the combustion chamber. If an oil seal is damaged or deteriorated, oil consumption will increase, and carbon may build up in the combustion chambers. This may be indicated by white exhaust smoke.

If an oil seal appears damaged or deteriorated or if there is any doubt as to its condition, replace it with a new one.

CYLINDER BLOCK, PISTONS

Compression measurement

A compression test is useful in determining the condition of the engine. Low compression may be due to cylinder wear; worn piston ring grooves; worn, broken, or sticking piston rings; poor valve seating; cylinder head leaks; or damage to the engine such as piston seizure. Too high compression may be due to carbon built-up on the piston heads and cylinder head. Difference in compression between the cylinders may cause poor running.

Before measuring compression, check that the cylinder head is tightened down with the specified torque (Pg. 46) and that the battery is fully charged (Pg. 156) and thoroughly warm up the engine so that engine oil between the pistons and cylinder walls will help seal compression as it does during normal running. While the engine is running, check that there is no gas leakage from around the cylinder head gasket and from the spark plugs.

Stop the engine, remove the spark plugs, and attach the compression gauge (special tool) firmly into one spark plug hole. Using the starter motor, turn the engine over with the throttle fully open until the compression gauge stops rising; the compression is the highest reading obtainable. Repeat the measurement for the other cylinder.

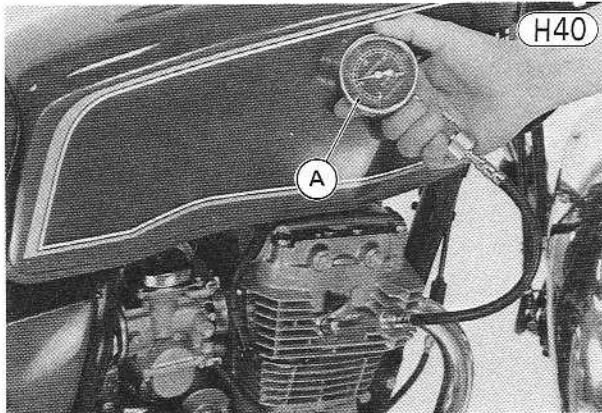

A. Compression Gauge (57001-221, 57001-1018)

Table H26 Cylinder Compression*

| Usable Range |
|---|
| 8.4 ~ 13.0 kg/cm ² (119 ~ 185 psi), and less than 1 kg/cm ² (14 psi) difference between the cylinders |

*Engine hot, spark plugs removed, throttle fully opened, cranking the engine with the starter motor.

If cylinder compression is higher than the usable range, check the following:

1. Carbon build-up on the piston head and cylinder head – clean off any carbon on the piston head and cylinder head.
2. Cylinder head gasket, cylinder base gasket – use only the proper gasket for the cylinder head. The use of a gasket of incorrect thickness will change the compression.

3. Valve stem oil seals and piston rings – rapid carbon accumulation in the combustion chambers may be caused by damaged valve stem oil seals and/or damaged piston oil rings. This may be indicated by white exhaust smoke.
4. Cylinder head volume (Pg. 121).

If cylinder compression is lower than the usable range, check the following:

1. Gas leakage around the cylinder head – replace the damaged gasket and check the cylinder head warp (Pg. 121).
2. Condition of the valve seating (Pg. 124).
3. Valve clearance (Pg. 16).
4. Piston/cylinder clearance, piston seizure
5. Piston ring, piston ring groove

Cylinder, piston wear

Since there is a difference in cylinder wear in different directions, take a side-to-side and a front-to-back measurement at each of the 3 locations (total of 6 measurements) shown in Fig. H41. If any of the cylinder inside diameter measurements exceeds the usable range, the cylinder will have to be bored to oversize and then honed. However, if the amount of boring necessary would make the inside diameter greater than 56.000 mm, the cylinder block must be replaced.

Cylinder Inside Diameter Measurement

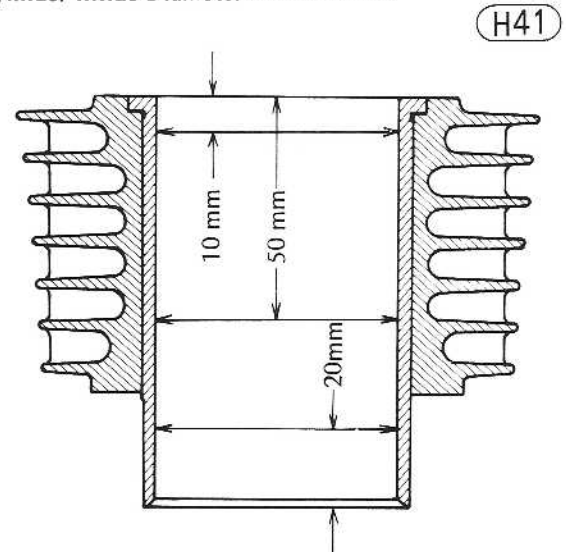

Table H27 Cylinder Inside Diameter

| Standard | Usable Range |
|---|--|
| 55.000 ~ 55.012 mm, and less than 0.01 mm difference between any two measurements | 55.10 mm, or more than 0.05 mm difference between any two measurements |

Measure the outside diameter of each piston 5 mm up from the bottom of the piston at a right angle to the direction of the piston pin. If the measurement is under the service limit, replace the piston.

128 MAINTENANCE—ENGINE

NOTE: Abnormal wear such as a marked diagonal pattern across the piston skirt may mean a bent connecting rod or crankshaft.

Piston Diameter Measurement

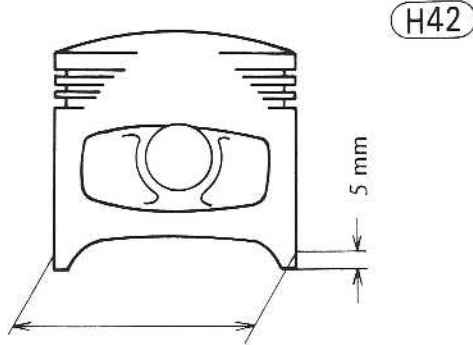

Table H28 Piston Diameter

| Standard | Service Limit |
|------------------|---------------|
| 54.955~54.970 mm | 54.80 mm |

Table H27 applies only to a cylinder that has not been bored to oversize, and Table H28 applies only to the standard size piston. In the case of a rebored cylinder and oversize piston, the usable range for the cylinder is the diameter that the cylinder was bored to plus 0.1 mm and the service limit for the piston is the oversize piston original diameter minus 0.15 mm. If the exact figure for the rebored diameter is unknown, it can be roughly determined by measuring the diameter at the base of the cylinder.

NOTE: Whenever a piston or cylinder block has been replaced with a new one, the motorcycle must be broken in, the same as with a new machine.

Piston/cylinder clearance

The piston-to-cylinder clearance is measured whenever a piston or the cylinder block is replaced with a new one, or whenever a cylinder is rebored and an oversize piston is installed. The standard piston-to-cylinder clearance must be adhered to whenever the cylinder block is replaced or a cylinder rebored. If only a piston is replaced, the clearance may exceed the standard slightly. But it must not be less than the minimum, in order to avoid piston seizure.

The most accurate way to find the piston clearance is by making separate piston and cylinder diameter measurements and then computing the difference between the two values. Measure the piston diameter as just described, and measure the cylinder diameter at the very bottom of the cylinder.

Table H29 Piston/Cylinder Clearance

| Standard |
|----------------|
| 0.030~0.057 mm |

Boring, honing

When boring and honing a cylinder, note the following:

1. Before boring a cylinder, first measure the exact diameter of the oversize piston, and then, in accordance with the standard clearance given in Table H28, determine the diameter of the rebore.
2. Cylinder inside diameter must not vary more than 0.006 mm at any point.
3. There are two sizes of oversize pistons available: 0.5 mm and 1.0 mm. Oversize pistons require oversize rings.
4. Be wary of measurements taken immediately after boring since the heat affects cylinder diameter.

Piston/cylinder seizure

Remove the cylinder block and pistons to check the damage. If there is only slight damage, the piston may be smoothed with #400 emery cloth, and any aluminum deposits removed from the cylinder with either #400 emery cloth or light honing. However, in most cases, the cylinder will have to be bored to oversize and honed, and an oversize piston installed.

Piston cleaning

Built-up carbon on the piston head reduces the cooling capability of the piston and raises compression, leading to overheating which could possibly even melt the top of the piston. To decarbonize the piston head, remove the piston (Pg. 53), scrape off the carbon, and then lightly polish the piston with fine emery cloth.

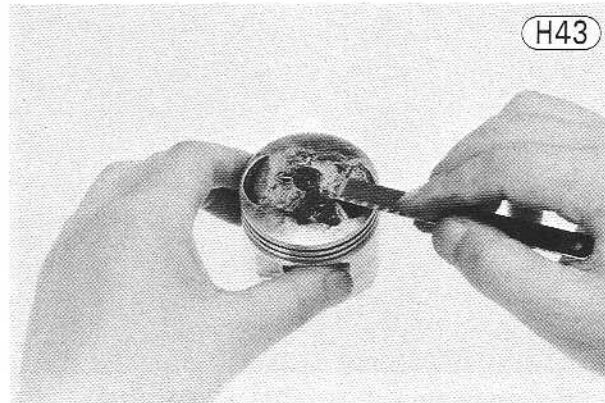

Carbon accumulated in the piston ring grooves can cause the rings to stick. Remove the rings, and clean out any carbon deposits using the end of a broken piston ring or some other suitable tool.



- CAUTION** 1. When removing carbon, take ample care not to scratch the side of the piston, or the piston ring grooves.
2. Never clean the piston heads with the piston installed. If this is done, carbon particles will unavoidably drop between the pistons and cylinder walls and eventually find their way into the crank chamber. Carbon particles, which are very abrasive, drastically shorten the life of the rings, pistons, cylinder, crankshaft bearings, and oil seals.

Piston ring, piston ring groove wear

Visually inspect the piston rings and the piston ring grooves. If the rings are worn unevenly or damaged, they must be replaced. If the piston ring grooves are worn unevenly or damaged, the piston must be replaced and fitted with new rings.

With the piston rings in their grooves, make several measurements with a thickness gauge to determine piston ring/groove clearance. If the clearance exceeds the service limit, measure the thickness of the piston rings and the width of the ring grooves. If the ring has worn down to less than the service limit, replace the ring; if the groove width exceeds the service limit, replace the piston.

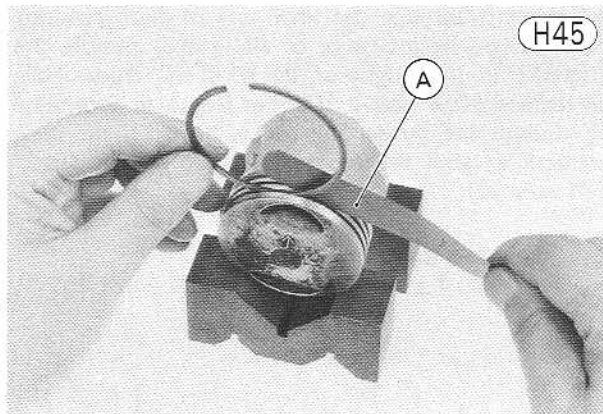

A. Thickness Gauge

Table H30 Piston Ring/Groove Clearance

| | Standard | Service Limit |
|----------|--------------|---------------|
| Top Ring | 0.01~0.05 mm | 0.15 mm |
| 2nd Ring | 0.04~0.08 mm | 0.18 mm |

Table H31 Piston Ring Thickness

| | Standard | Service Limit |
|----------|--------------|---------------|
| Top Ring | 1.47~1.49 mm | 1.4 mm |
| 2nd Ring | 1.17~1.19 mm | 1.1 mm |

Table H32 Piston Ring Groove Width

| | Standard | Service Limit |
|----------|--------------|---------------|
| Top Ring | 1.50~1.52 mm | 1.6 mm |
| 2nd Ring | 1.23~1.25 mm | 1.3 mm |

When new rings are being fitted into a used piston, check for uneven groove wear by inspecting the ring seating. The rings should fit perfectly parallel to the groove surfaces. If not, the piston must be replaced.

Piston ring end gap

Place the piston ring inside the cylinder, using the piston to locate the ring squarely in place. Set it close to the bottom of the cylinder, where cylinder wear is low. Measure the gap between the ends of the ring with a thickness gauge. If the gap is wider than the service limit, the ring is worn and must be replaced.

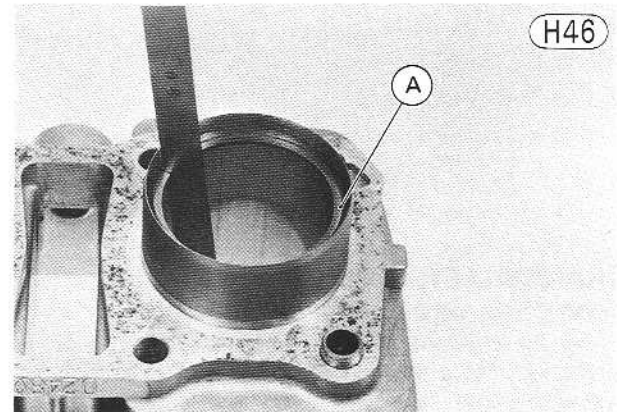

A. Piston Ring

Table H33 Ring End Gap

| | Standard | Service Limit |
|----------|--------------|---------------|
| Top Ring | 0.15~0.35 mm | 0.7 mm |
| 2nd Ring | 0.15~0.35 mm | 0.7 mm |
| Oil Ring | 0.15~0.75 mm | 1.1 mm |

Piston, piston pin, connecting rod wear

Measure the diameter of the piston pin with a micrometer, and measure the inside diameter of both piston pin holes in the piston. If the piston pin diameter is less than the service limit at any point, replace the piston pin. If either piston pin hole diameter exceeds the service limit, replace the piston.

Measure the inside diameter of the connecting rod small end. If the diameter exceeds the service limit, replace the connecting rod.

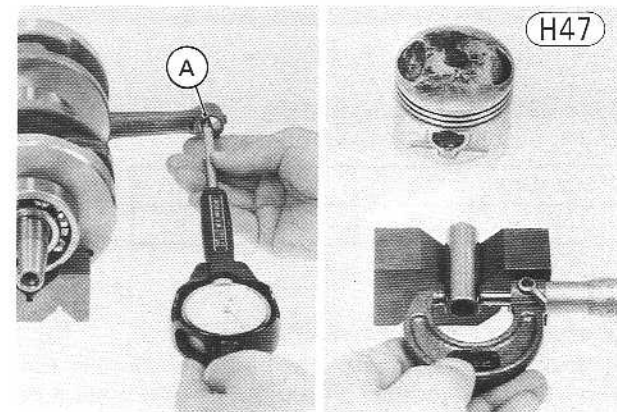

A. Connecting Rod Small End

130 MAINTENANCE—ENGINE

Table H34 Piston Pin, Piston Pin Hole,
Small End Diameter

| | Standard | Service Limit |
|------------|------------------|---------------|
| Piston Pin | 14.995~15.000 mm | 14.96 mm |
| Pin Hole | 15.005~15.011 mm | 15.07 mm |
| Small End | 15.003~15.014 mm | 15.05 mm |

NOTE: When a new piston or pin is used, also check that piston-to-pin clearance is 0.005 ~ 0.016 mm, and that pin to small end clearance is within 0.003 ~ 0.019 mm.

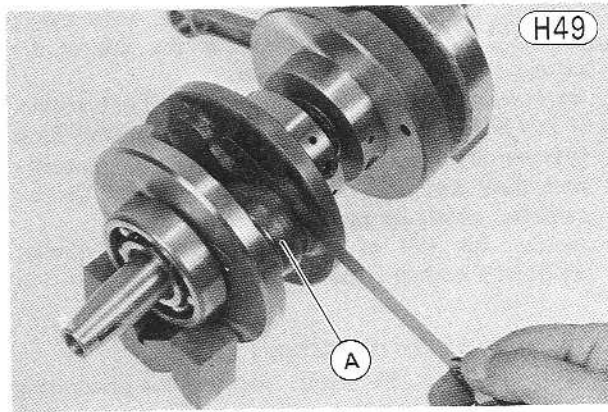

A. Big End

Table H36 Connecting Rod Big End Side Clearance

| Standard | Service Limit |
|------------|---------------|
| 0.2~0.3 mm | 0.5 mm |

CRANKSHAFT, CONNECTING RODS

Connecting rod big end radial clearance

Set the crankshaft in a flywheel alignment jig or on V blocks. Set a dial gauge against the big end of the connecting rod, and first push the connecting rod toward the gauge and then in the opposite direction. The difference between the two gauge readings is the radial clearance.

If radial clearance exceeds the service limit, the crankshaft should be replaced.

Connecting rod bend, twist

Set the crankshaft in a flywheel alignment jig or on V blocks on a surface plate. Select an arbor of the same diameter as the piston pin and of optional length, and insert it through the small end of the connecting rod. Using a height gauge or dial gauge, measure the difference in the height of the small-end arbor above the surface plate over a 100 mm length to determine the amount the connecting rod is bent. If the measurement exceeds the service limit, replace the crankshaft assembly.

Connecting Rod Bend Measurement

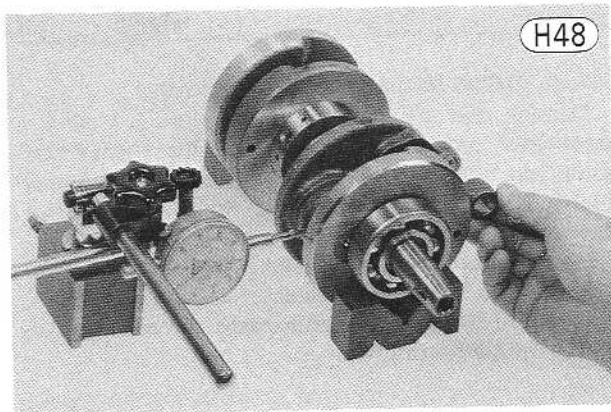
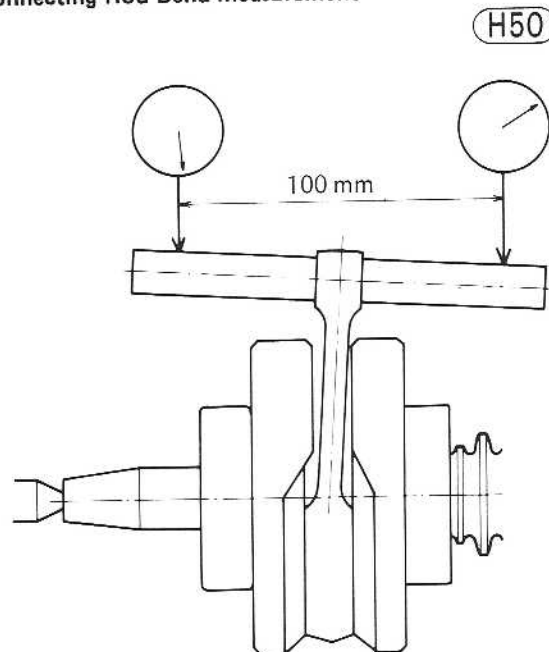

Table H35 Connecting Rod Big
End Radial Clearance

| Standard | Service Limit |
|----------------|---------------|
| 0.008~0.016 mm | 0.07 mm |

Connecting rod side clearance

Measure the side clearance of the connecting rod with a thickness gauge as shown. Replace the crankshaft and the connecting rod if the clearance exceeds the service limit.



Using the arrangement and arbor shown below, measure the amount that the arbor varies from being parallel with the crankshaft over a 100 mm length of the arbor to determine the amount the connecting rod is twisted.

If the measurement exceeds the service limit replace the crankshaft assembly.

Connecting Rod Twist Measurement

H51

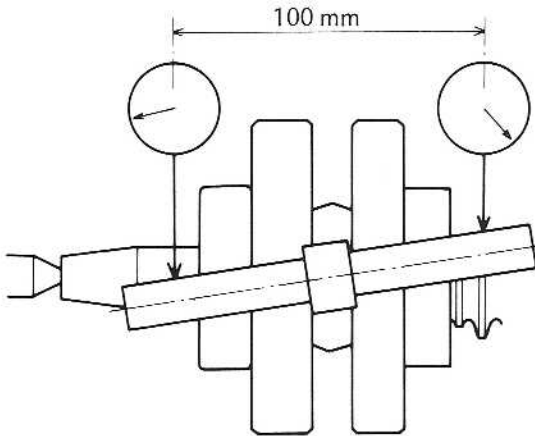

Table H37 Connecting Rod Bend, Twist/100 mm

| | Standard | Service Limit |
|-------|---------------|---------------|
| Bend | under 0.05 mm | 0.2 mm |
| Twist | under 0.05 mm | 0.2 mm |

Crankshaft runout

With the four crankshaft bearings in place, set the crankshaft in V blocks, suspending it at the both inner bearing outer races.

Set a dial gauge against each of the other bearings and turn the crankshaft slowly. The difference between the highest and lowest dial gauge reading for the bearing is the runout.

If the runout measured at any bearing exceeds the service limit, the crankshaft should be replaced.

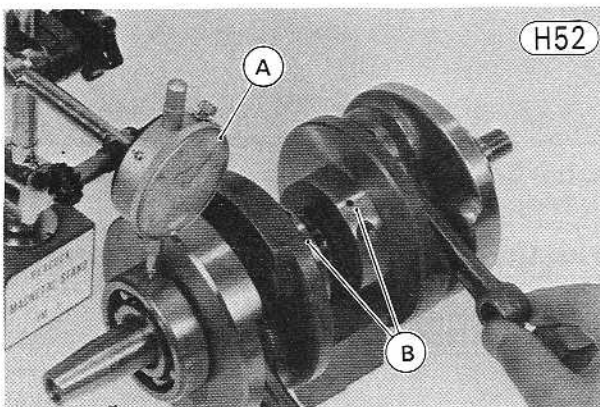

A. Dial Gauge B. Crankshaft Bearings

Table H38 Crankshaft Runout

| Standard | Service Limit |
|---------------|---------------|
| under 0.04 mm | 0.10 mm |

Main bearing wear

The crankshaft bearings are made to very close tolerance, and bearing play would be difficult to measure even if all the bearings could be removed. The worth of the bearing, therefore, must be judged by feel.

Wash the bearings in a high flash-point solvent, blow them dry (**DO NOT SPIN THEM**), and lubricate them. Turn each bearing over by hand and see that it makes no noise, turns smoothly, and has no rough spots. If either of the two end bearings is defective, the bearing can be replaced, but the other two bearings can be replaced only as an assembly with the crankshaft.

CLUTCH

Spring tension

Remove the clutch springs, and set them, one at a time, on a spring tension testing device. Compress the spring, and read the tension at the test length. If the spring tension at the specified length is weaker than the service limit, replace the spring.

Table H39 Clutch Spring Tension

| Length | Standard | Service Limit |
|--------|--------------|---------------|
| 24 mm | 14.4~17.6 kg | 13 kg |

Friction plate wear, damage

Visually inspect the friction plates to see whether or not they show any signs of seizure, overheating, or uneven wear. Measure the thickness of the plates with vernier calipers.

If any plates show signs of damage, or if they have worn past the service limit, replace them with new ones.

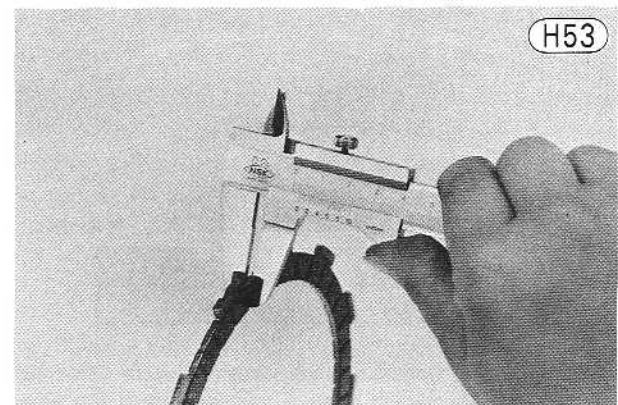

Table H40 Friction Plate Thickness

| Standard | Service Limit |
|--------------|---------------|
| 2.92~3.08 mm | 2.7 mm |

Clutch plate wear

Place each clutch plate on a surface plate, and measure the gap between each clutch plate and the surface

132 MAINTENANCE—ENGINE

plate. This gap is the amount of clutch plate warp. Replace any plates warped over the service limit.

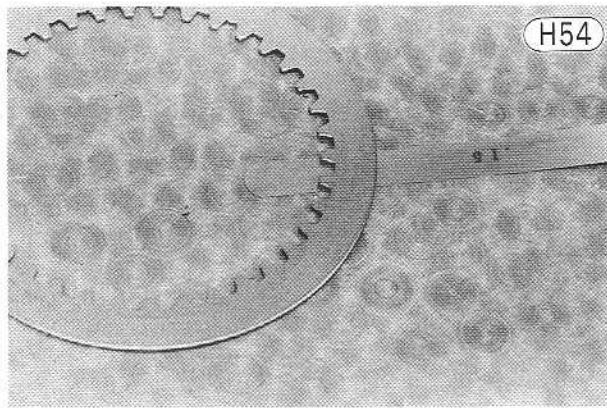

Table H41 Clutch Plate Warp

| Standard | Service Limit |
|--------------|---------------|
| under 0.2 mm | 0.4 mm |

Friction plate/clutch housing clearance

Measure the clearance between the tangs on the friction plates and the fingers of the clutch housing. If this clearance is excessive, the clutch will be noisy.

If the clearance exceeds the service limit, replace the friction plates. Also, replace the clutch housing if it is unevenly or badly worn where the friction plates wear against it.

Friction Plate/Clutch Housing Clearance

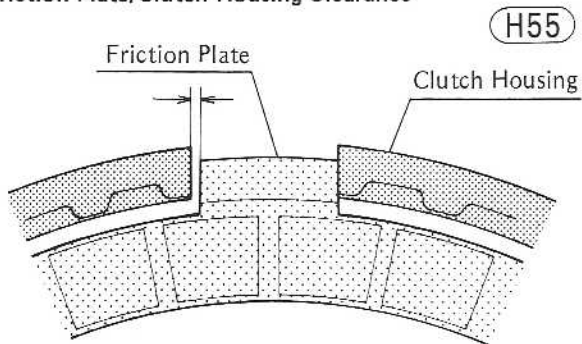

Table H42 Friction Plate/Clutch Housing Clearance

| Standard | Service Limit |
|--------------|---------------|
| 0.05~0.45 mm | 0.70 mm |

Inspect the fingers of the housing where the tangs of the friction plates hit them. If they are badly worn or if there are grooves cut where the tangs hit, replace the clutch housing.

Clutch housing gear damage

Inspect the teeth on the clutch housing gear. Any light damage can be corrected with an oilstone, but the clutch housing must be replaced if the teeth are badly damaged. Damaged teeth on the clutch housing gear indicate that the primary gear, by which it is driven,

may also be damaged. At the same time that the clutch housing gear is repaired or replaced, the primary gear should be inspected. If damaged, the primary gear must be replaced.

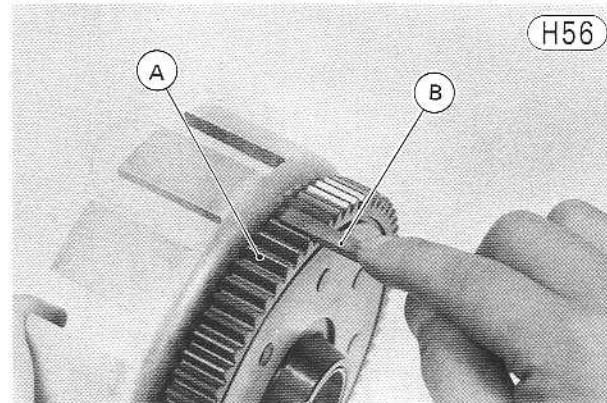

A. Clutch Housing Gear B. Oil Stone

Clutch housing/primary gear backlash

Split the crankcase. Leaving the drive shaft and crankshaft in place, measure the backlash between the clutch housing gear and the primary gear. To measure the backlash, set a dial gauge against the teeth of one gear, and move the gear back and forth while holding the other gear steady. The difference between the highest and the lowest gauge reading is the amount of backlash. Replace both the clutch housing and the primary gear whenever the amount of backlash exceeds the service limit.

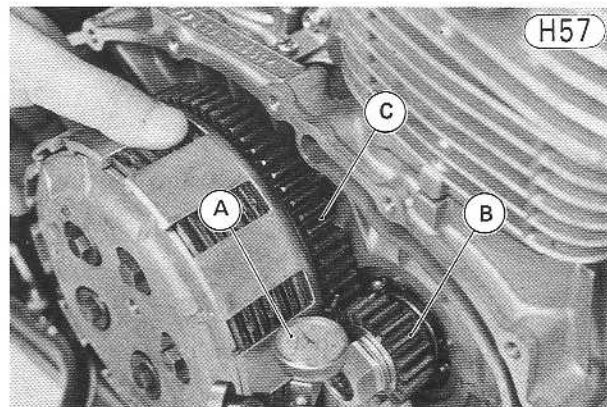

**A. Dial Gauge C. Clutch Housing Gear
B. Primary Gear**

Table H43 Clutch Housing/Primary Gear Backlash

| Standard | Service Limit |
|---------------|---------------|
| under 0.11 mm | 0.15 mm |

Clutch housing/drive shaft sleeve wear

Measure the diameter of the drive shaft sleeve with a micrometer. Replace the drive shaft sleeve if the diameter is less than the service limit. Measure the inside diameter of the clutch housing with a cylinder gauge. Replace the clutch housing if the diameter exceeds the service limit.

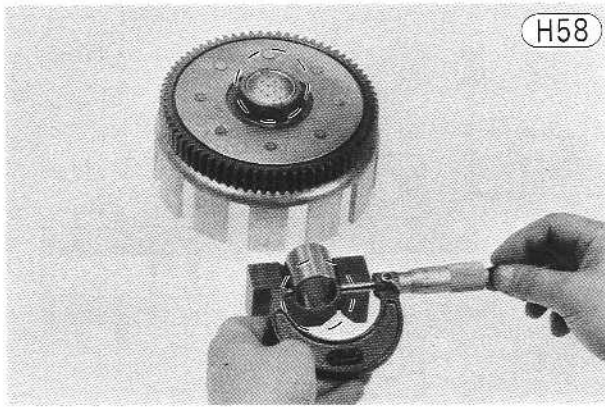

Table H44 Clutch Housing, Drive Shaft Sleeve Diameter

| | Standard | Service Limit |
|--------------|------------------|---------------|
| Housing I.D. | 30.020~30.041 mm | 30.06 mm |
| Sleeve O.D. | 29.087~30.000 mm | 29.07 mm |

Clutch hub damage

Inspect where the teeth on the steel plates wear against the splines of the clutch hub. If there are notches worn into the splines, replace the clutch hub.

Clutch release mechanism wear

Visually inspect the clutch release lever, balls, and ball ramp for damage or excessive wear. If there is any damage or excessive wear, replace the clutch release lever, balls, and ball ramp as a set.

Lubrication

Lubricate the clutch release lever, balls, and ball ramp with grease.

TRANSMISSION

Shift Mechanism

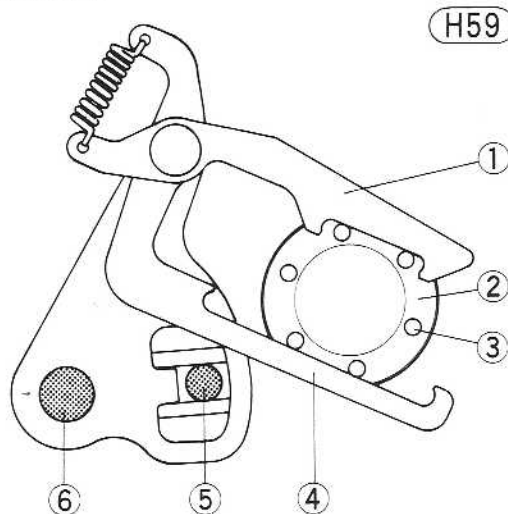

- 1. Shift Arm
- 2. Shift Drum
- 3. Shift Drum Pin
- 4. Over Shift Limiter
- 5. Return Spring Pin
- 6. Shift Shaft

External shift mechanism inspection

Inspect the shift arm, overshift limiter, arm spring, and return spring. Replace any broken or otherwise damaged parts.

Measure the free length of the arm spring. If it is longer than the service limit, replace it with a new one.

Measure the free length of the shift positioner springs. If it is longer than the service limit, replace it with a new one.

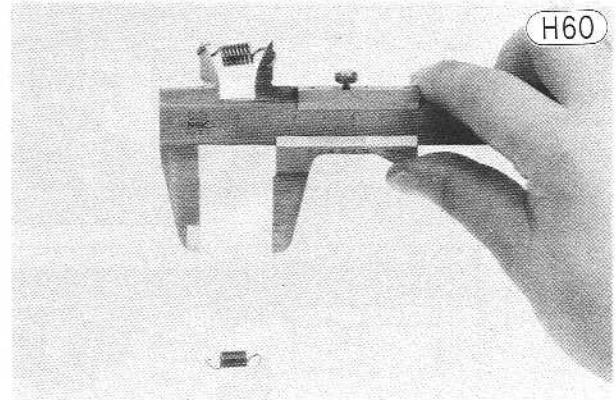
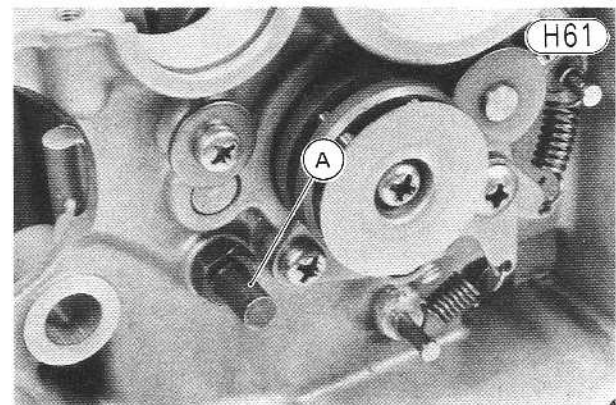

Table H45 Shift Arm Spring, Shift Positioner Spring Free Length

| | Standard | Service Limit |
|------------|----------|---------------|
| Shift Arm | 18.0 mm | 19 mm |
| Positioner | 22.5 mm | 24 mm |

Check to see if the return spring pin is loose. If it is, remove it and apply a non-permanent locking agent to the threads. Then tighten it.



A. Return Spring Pin

Gear backlash

Split the crankcase. Leaving the drive shaft and output shaft assembly in place, measure the backlash between gears O1 and D1, O2 and D2, O3 and D3, O4 and D4, O5 and D5, O6 and D6. To measure the backlash, set a dial gauge against the teeth on one gear, and move the gear back and forth while holding the other gear steady. The difference between the highest and the lowest gauge reading is the amount of backlash. Replace both gears if the amount of backlash exceeds the service limit.

Transmission

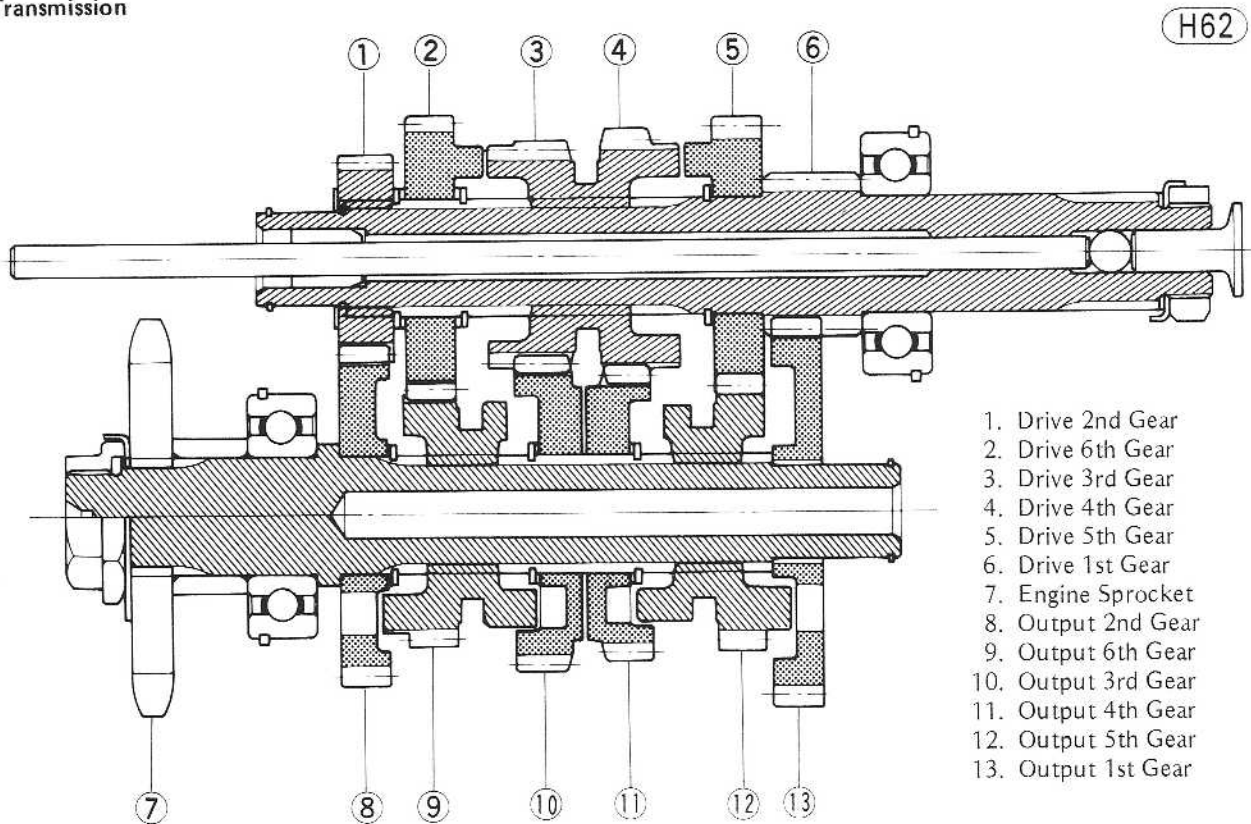
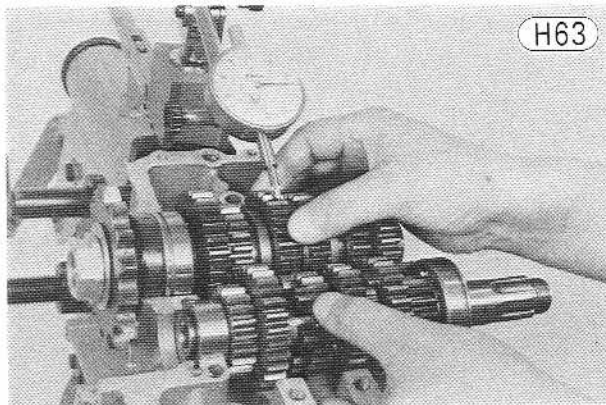

Table H46 Gear Backlash

| Standard | Service Limit |
|-----------|---------------|
| 0~0.17 mm | 0.25 mm |

Table H47 Shift Fork Thickness

| Standard | Service Limit |
|----------------|---------------|
| 4.830~4.900 mm | 4.7 mm |



Shift fork bending

Visually inspect the shift forks, and replace any fork that is bent. A bent fork could cause difficulty in shifting or allow the transmission to jump out of gear when under power.

Shift fork/gear groove wear

Measure the thickness of the ears of each shift fork, and measure the width of the shift fork grooves on gears D3/4, O5, and O6. If the thickness of a shift fork ear is under the service limit, the shift fork must be replaced. If a gear shift fork groove is worn over the service limit, the gear must be replaced.

Table H48 Gear Shift Fork Groove Width

| Standard | Service Limit |
|--------------|---------------|
| 5.05~5.15 mm | 5.25 mm |

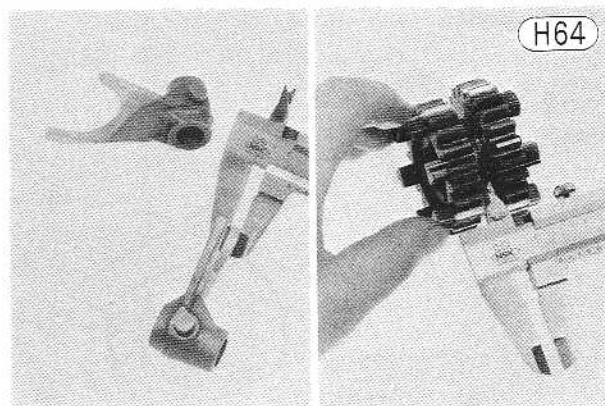

Shift fork guide pin/shift drum groove wear

Measure the diameter of each shift fork guide pin, and measure the width of each shift drum groove. If the guide pin has worn past the service limit, replace the shift fork. If a shift drum groove is worn past the service limit, replace the shift drum.

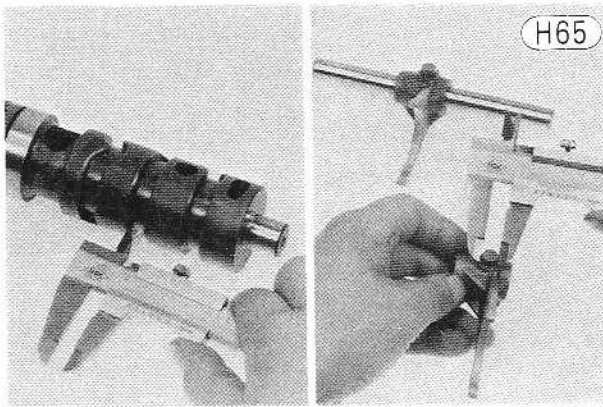
Table H49 Shift Fork Guide Pin Diameter

| Standard | Service Limit |
|----------------|---------------|
| 5.990~6.005 mm | 5.85 mm |

Table H50 Shift Drum Groove Width

| Standard | Service Limit |
|--------------|---------------|
| 6.05~6.20 mm | 6.25 mm |

Gear dog, gear dog hole, gear dog recess damage

Visually inspect the gear dogs, gear dog holes, and gear dog recesses. Replace any gears that have damaged, or unevenly or excessively worn dogs, dog holes, or dog recesses.

Gear/shaft wear

Measure the diameter of each shaft and bush with a micrometer, and measure the inside diameter of each gear listed below. Find the difference between the two readings to figure clearance, and replace any gear with clearance exceeding the service limit.

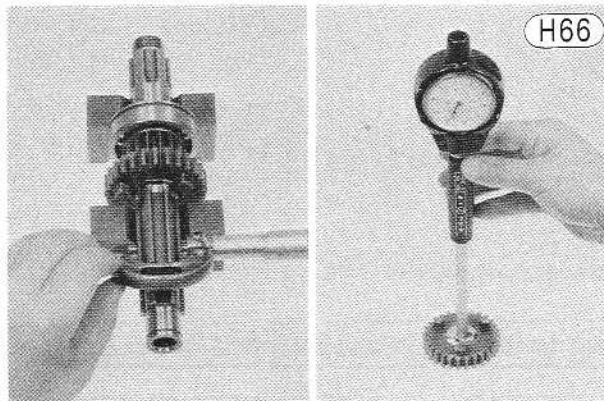
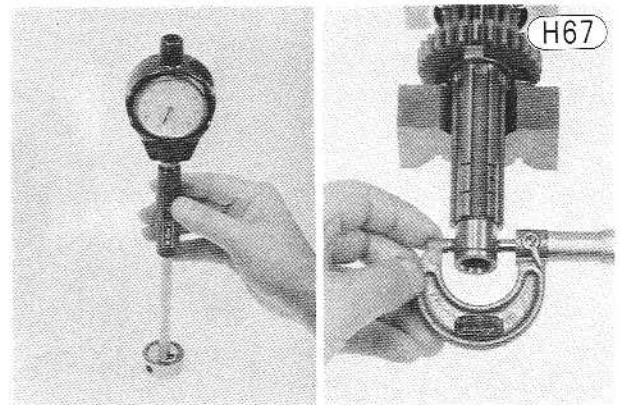

Table H51 Gear/Shaft, Gear/Bush Clearance

| Gear | Standard | Service Limit |
|----------------|----------------|---------------|
| O1, O2 | 0.027~0.061 mm | 0.16 mm |
| O3, D5, and D6 | 0.020~0.062 mm | 0.16 mm |

Shaft/needle bearing outer race wear

Measure the diameter of the drive and output shafts where it passes through the needle bearing. Replace the shaft if the diameter is less than the service limit.

Measure the inside diameter of the needle bearing outer race with a cylinder gauge. Replace the needle bearing outer race if the diameter exceeds the service limit. When replacing the shaft and/or needle bearing outer race, replace the needle bearing also.

Table H52 Shaft Needle Bearing Outer Race Wear

| | Standard | Service Limit |
|------------|------------------|---------------|
| D. Shaft | 19.987~20.000 mm | 19.97 mm |
| O. Shaft | 19.980~19.993 mm | 19.96 mm |
| Outer Race | 25.007~25.020 mm | 25.04 mm |

Ball bearing, needle bearing wear, damage

Check the ball bearing and needle bearing (Pg. 138). If there is any doubt as to the condition of either bearing, replace it.

LUBRICATION

Engine Oil Pump

Oil pump operation check

If it is suspected that the oil pump is not working properly, check the oil pump operation as follows:

- Disconnect the left spark plug lead, and remove the contact breaker cover and gasket.
- Remove the oil passage plug from the cylinder head.

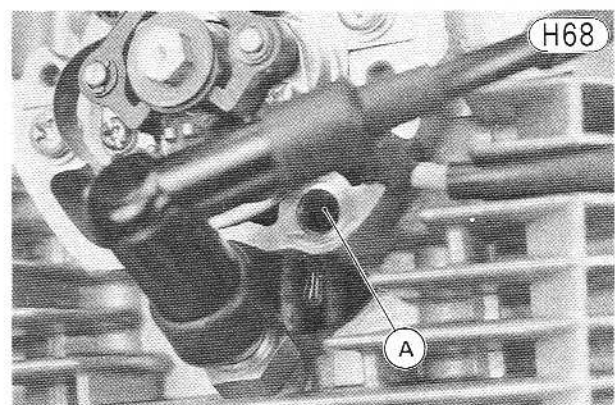
A. Oil Passage Plug Hole

- Connect the spark plug lead. Place a piece of cloth around the plug hole.

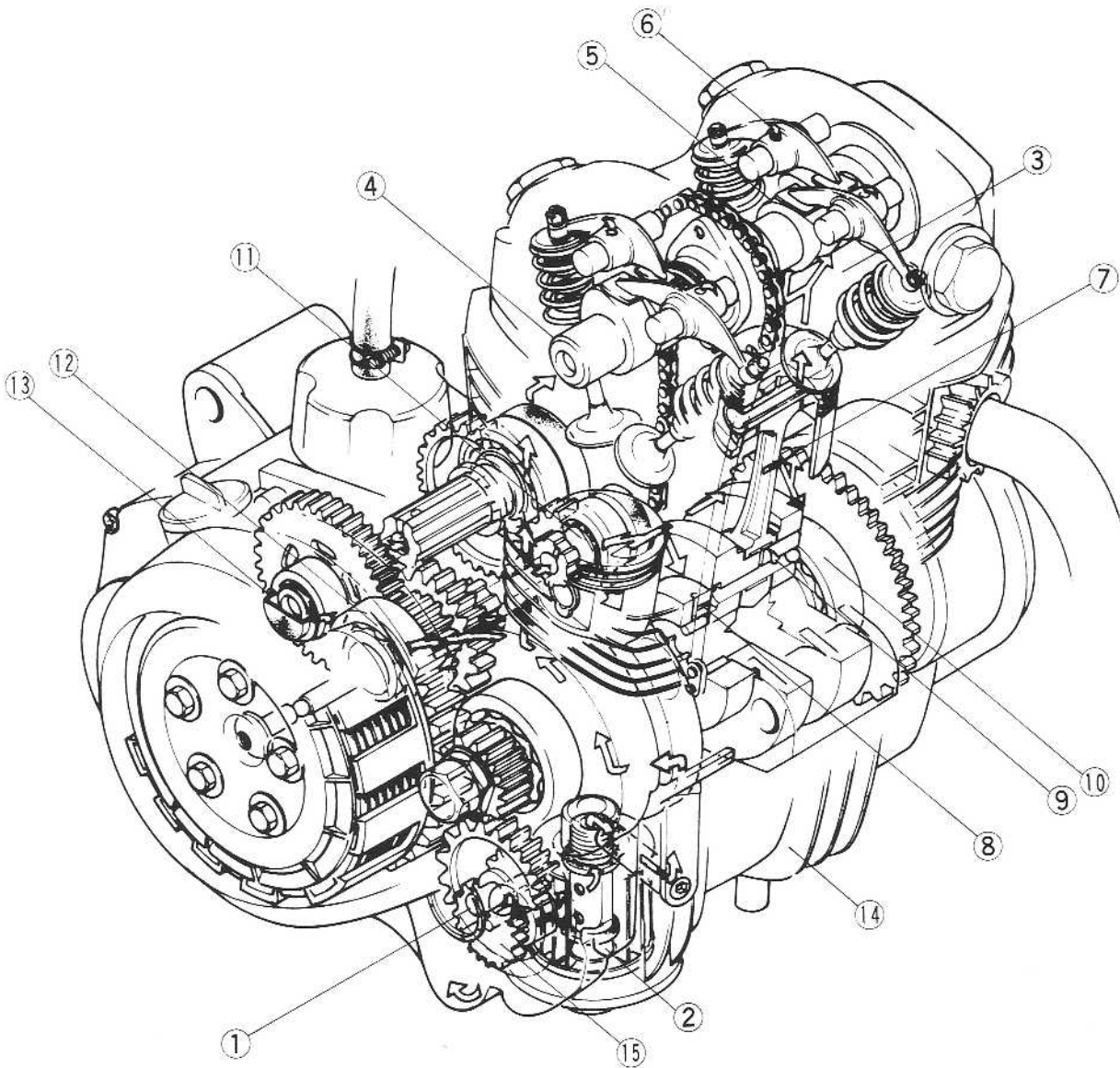

Engine Oil Flow Chart

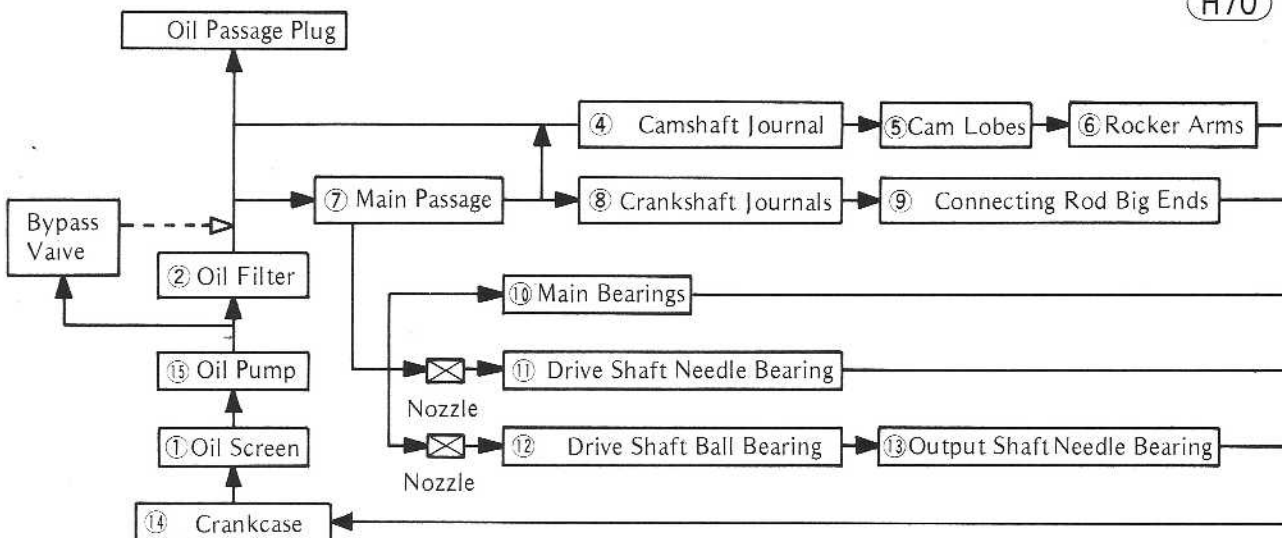

- Start the engine and let it idle.
- If the oil comes out, the oil pump is supposed to be good. If it does not, check the oil pump parts.

WARNING Be careful so as to not suffer a burn from the hot oil, when the engine is hot.

- Stop the engine.
- Clean the oil passage and plug threads, and apply a non-permanent locking agent to the oil passage plug threads. Tighten the plug to 1.0 kg-m (87 in-lbs) of torque.
- Install the contact breaker cover.

Outer rotor/inner rotor clearance

Measure the clearance between the outer rotor and inner rotor with a thickness gauge. If the clearance exceeds the service limit, replace the oil pump assembly.

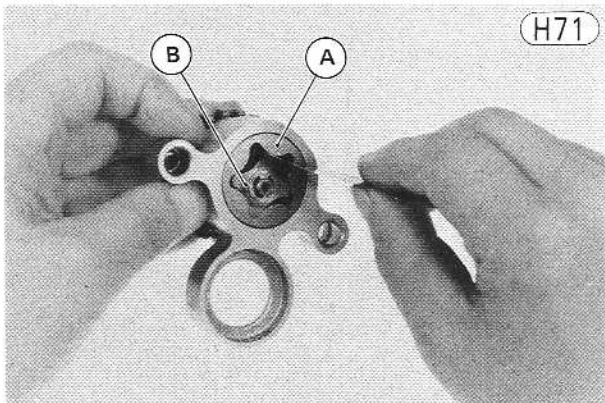

A. Outer Rotor B. Inner Rotor

Table H53 Outer Rotor/Inner Rotor Clearance

| Standard | Service Limit |
|---------------|---------------|
| under 0.15 mm | 0.21 mm |

Outer rotor/pump body clearance

Measure the clearance between the outer rotor and the pump body with a thickness gauge. If the clearance exceeds the service limit, replace the oil pump assembly.

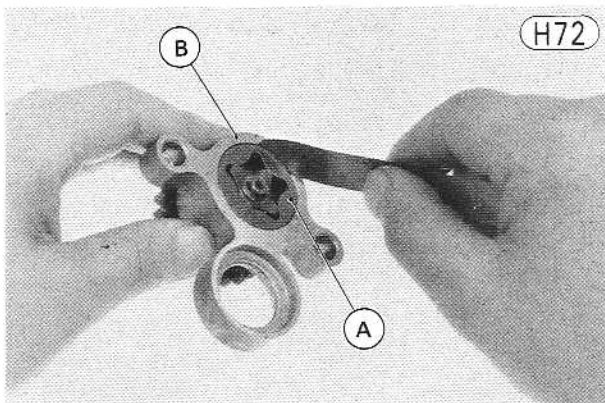

A. Outer Rotor B. Pump Body

Table H54 Outer Rotor/Pump Body Clearance

| Standard | Service Limit |
|--------------|---------------|
| 0.15~0.21 mm | 0.30 mm |

Rotor side clearance

Lay a straightedge on the oil pump body, and measure the clearance between the straightedge and the rotors with a thickness gauge. If the clearance exceeds the service limit, replace the oil pump assembly.

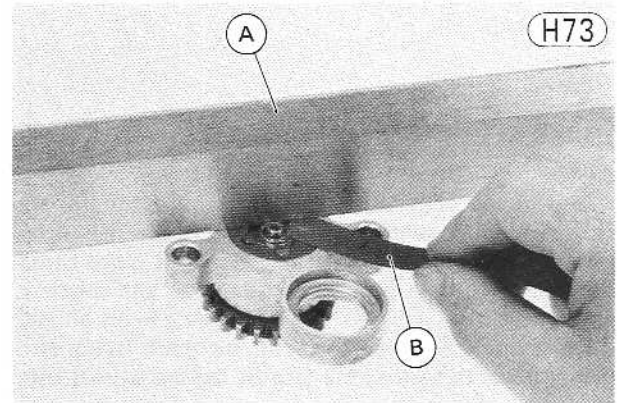

A. Straightedge B. Thickness Gauge

Table H55 Rotor Side Clearance

| Standard | Service Limit |
|--------------|---------------|
| 0.02~0.07 mm | 0.12 mm |

Oil Screen

The oil screen, installed in the lower part of the crankcase, removes any metal particles and other foreign matter which could damage the oil pump.

When the oil pump is removed, remove the oil screen, and clean any metal particles and other dirt out of the screen. If the oil screen is damaged, replace it with a new one.

Oil Filter

Replace the filter element in accordance with the Periodic Maintenance Chart (Pg. 10) since it becomes clogged with metal filings from the engine and transmission especially during break-in. After break-in, replace the element at every other oil change. When the filter is removed for element replacement, wash the rest of the filter parts in a high flash-point solvent and check the condition of the O rings. If they are worn or deteriorated, replace them to avoid oil leakage.

138 MAINTENANCE—ENGINE

BALL, NEEDLE BEARINGS

Ball bearing wear, damage

Since the ball bearings are made to extremely close tolerances, the wear must be judged by feel rather than by measurement.

Clean each bearing in a high flash-point solvent, dry it (do not spin it while it is dry), and oil it. Spin it by hand to check its condition. If it is noisy, does not spin smoothly, or has any rough spots, replace it.

Needle bearing wear, damage

The rollers in the needle bearings wear so little that the wear is difficult to measure. Instead, inspect the bearings for abrasion, color change, or other damage. If there is any doubt as to the condition of either bearing, replace it.

OIL SEALS

Oil seal damage

Inspect the oil seals, and replace any if the lips are misshapen, discolored (indicating the rubber has deteriorated), hardened, or otherwise damaged, since an oil seal is nearly always damaged on removal, and removed oil seals must be replaced. When pressing in an oil seal which is marked, press it in with the mark facing out. Press the seal in so that the face of the seal is level with the surface of its hole.

Maintenance—Chassis

Table of Contents

| | |
|-----------------------------------|-----|
| WHEELS | 140 |
| Tires | 140 |
| Rim..... | 140 |
| Axle | 143 |
| Wheel Bearings, Grease Seals..... | 143 |
| Rear Wheel Coupling | 143 |
| DRIVE CHAIN..... | 144 |
| SPROCKETS | 145 |
| BRAKES | 145 |
| STEERING STEM | 150 |
| FRONT FORK..... | 151 |
| SWING ARM | 152 |



WHEELS

Wheel construction is shown in Figs. J3, J4. The following sections, Pgs. 140~143 cover the tires, rims, axles, wheel bearings, and grease seals. For the brakes, see Pgs. 145~150.

Tires

Table J1 Tires, Air Pressure (measured when cold)

| | Air Pressure | | Size | Make, Type |
|-------|----------------------------------|------------------------------------|-----------------|----------------|
| Front | 1.75 kg/cm ² (25 psi) | | 3.00S-18 4PR | Dunlop F7 |
| Rear | Up to 97.5 kg | 2.0 kg/cm ² (28 psi) | 3.50S-18 4PR | Dunlop K102 |
| | Over 97.5~ 155 kg | 2.5 kg/cm ² (36 psi) | | |

Tire wear, damage

Tires must not be used if they are getting bald, or if they are cut or otherwise damaged. As the tire tread wears down, the tire becomes more susceptible to puncture and failure. 90% of tire failures occur during the last 10% of tire life.

Visually inspect the tire for cracks and cuts, replacing the tire in case of bad damage. Remove any imbedded stones or other foreign particles from the tread. Swelling or high spots indicate internal damage, requiring tire replacement unless the damage to the fabric is very minor.

Measure the depth of the tread with a depth gauge, and replace the tire if the tread depth is less than the service limit.

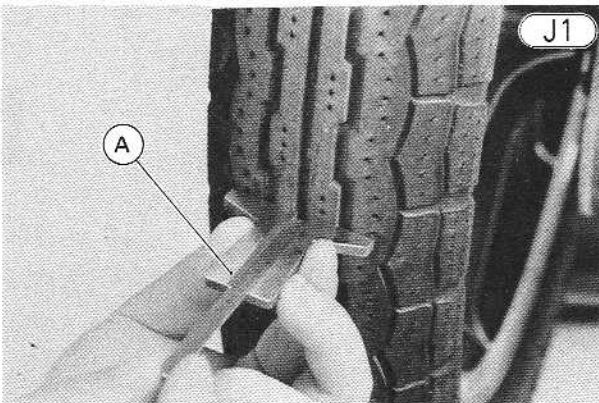

A. Depth Gauge

Table J2 Tire Tread Depth

| Tire | Standard | Minimum Tread Depth | |
|-------|----------|---------------------|------|
| Front | 3.5 mm | 1 mm | |
| Rear | 6.9 mm | under 110 kph | 2 mm |
| | | over 110 kph | 3 mm |

Rim

Rim runout

Carefully inspect the wheel for small cracks, dents, bends, or warpage. If there is any damage to the wheel, it must be replaced.

WARNING Never attempt to repair a damaged wheel. If there is any damage besides wheel bearings, the wheel must be replaced to insure safe operating condition.

Remove the tire and suspend the wheel by the axle. Set a dial gauge against the side of the rim, and rotate the wheel to measure the axial runout. The difference between the highest and lowest dial readings is the amount of runout.

Set the dial gauge to the outer circumference of the rim, and rotate the wheel to measure radial runout. The difference between the highest and lowest dial readings is the amount of runout.

Rim Runout Measurement

J2

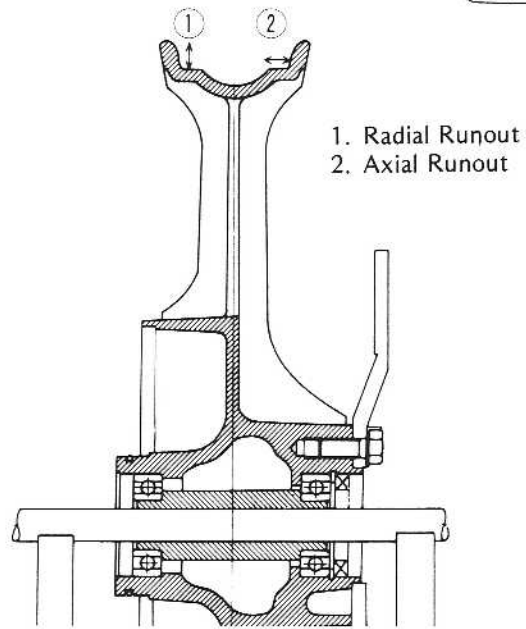

Table J3 Rim Runout (with tire removed)

| | Service Limit |
|--------|---------------|
| Axial | 0.5 mm |
| Radial | 0.8 mm |

If rim runout exceeds the service limit, check the wheel bearings first. Replace them if they are damaged. If the problem is not due to the bearings, the wheel must be replaced. Do not attempt to repair a damaged wheel.

Table J4 Rim Size

| | |
|-------|-----------|
| Front | 1.60 x 18 |
| Rear | 1.85 x 18 |

Front Wheel

J3

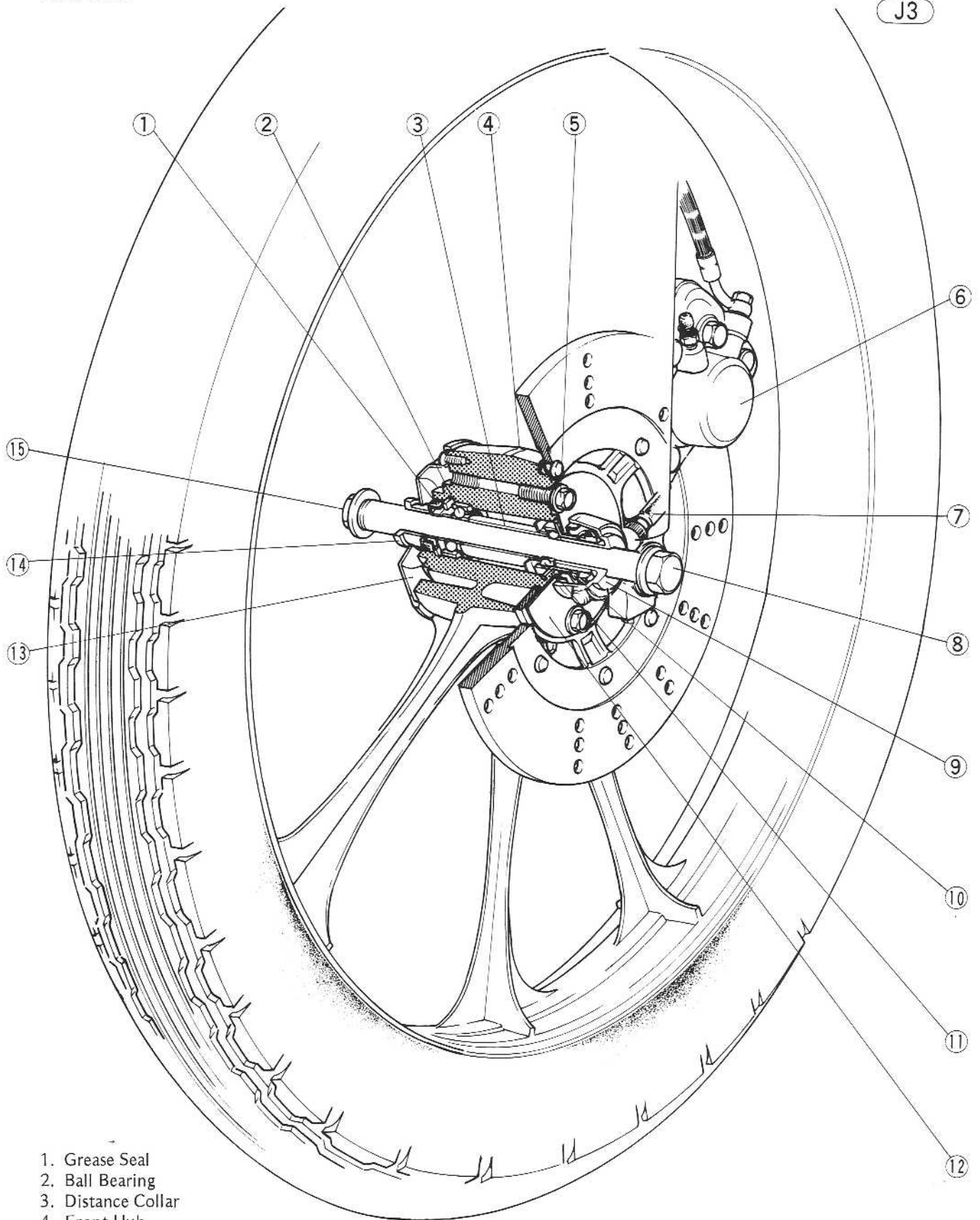

- 1. Grease Seal
- 2. Ball Bearing
- 3. Distance Collar
- 4. Front Hub
- 5. Disc Mounting Bolt

- 8. Front Axle
- 9. Speedometer Gear Housing
- 10. Speedometer Gear

- 11. Ball Bearing
- 12. Speedometer Gear Drive Holding Plate

- 13. Cap
- 14. Collar
- 15. Front Axle Nut

142 MAINTENANCE—CHASSIS

Rear Wheel

J4

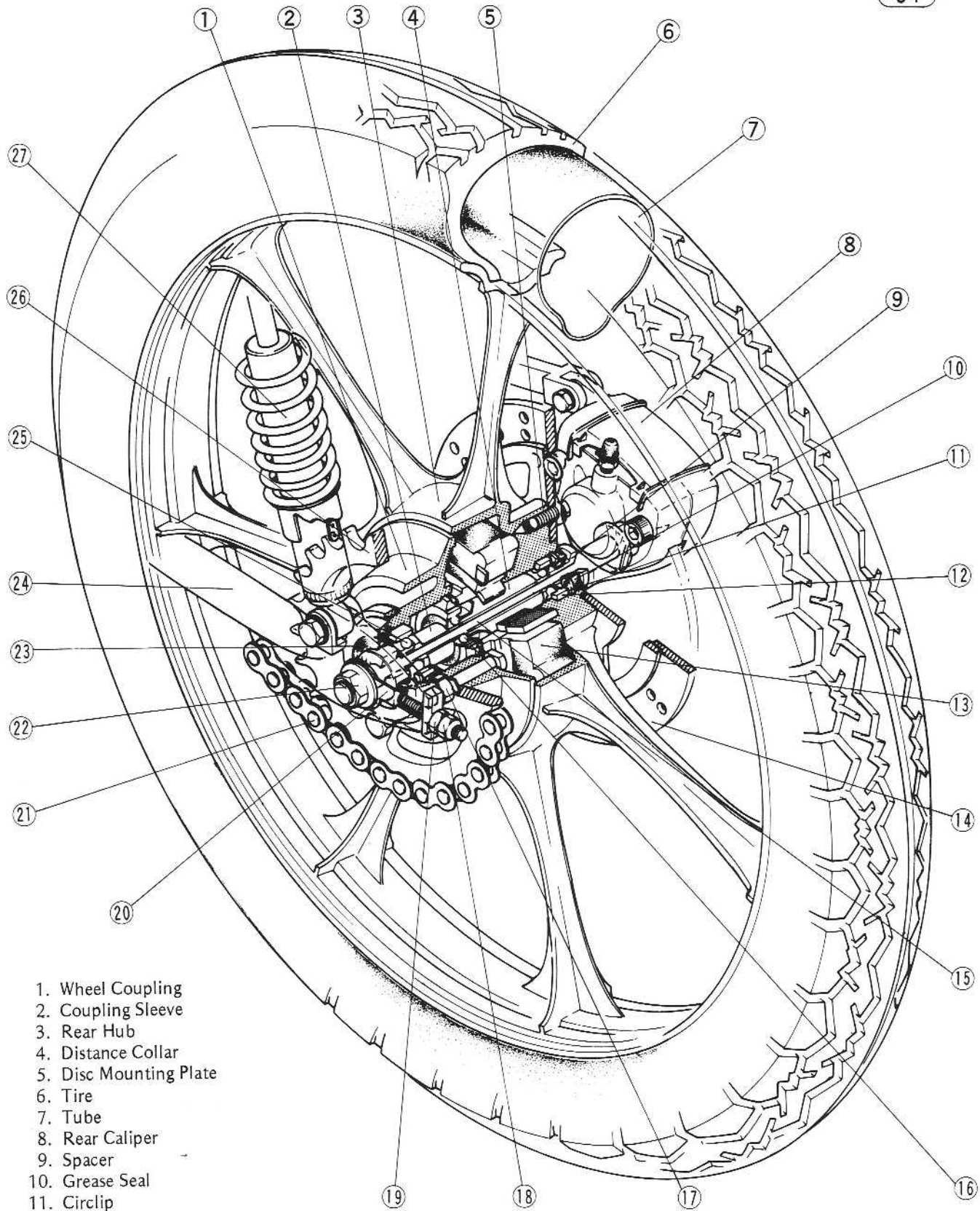

- 1. Wheel Coupling
- 2. Coupling Sleeve
- 3. Rear Hub
- 4. Distance Collar
- 5. Disc Mounting Plate
- 6. Tire
- 7. Tube
- 8. Rear Caliper
- 9. Spacer
- 10. Grease Seal
- 11. Circlip
- 12. Ball Bearing
- 13. Rubber Damper
- 14. Disc
- 15. Rear Axle
- 16. Ball Bearing

- 17. Rear Sprocket Mounting Nut
- 18. Locknut
- 19. Chain Adjusting Nut

- 20. Chain Adjuster
- 21. Drive Chain
- 22. Rear Axle Nut
- 23. Grease Seal

- 24. Swing Arm
- 25. Ball Bearing
- 26. Rear Sprocket
- 27. Rear Shock Absorber

Axle

A bent axle causes vibration, poor handling, and instability.

To measure axle runout, remove the axle, place it in V blocks that are 100 mm apart, and set a dial gauge to the axle at a point halfway between the blocks. Turn the axle to measure the runout. The amount of runout is the amount of dial variation.

If runout exceeds the usable range, straighten the axle or replace it. If the axle cannot be straightened to within usable range, or if runout exceeds the service limit, replace the axle.

Axle Runout

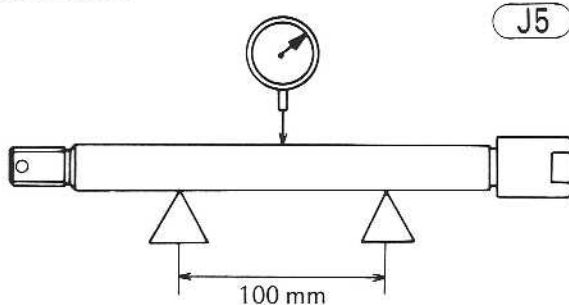

Table J5 Axle Runout/100 mm

| Standard | Usable Range | Service Limit |
|---------------|--------------|---------------|
| under 0.05 mm | 0.2 mm | 0.7 mm |

Wheel Bearings, Grease Seals

Inspection and lubrication

If the grease seals are examined without removing the seals themselves, look for discoloration (indicating the rubber has deteriorated), hardening, damage to the internal ribbing, or other damage. If the seal or internal ribbing has hardened, the clearance between the seal and the axle sleeve will not be taken up, which will allow dirt and moisture to enter and reach the bearing. If in doubt as to its condition and whenever the seal is removed for greasing the bearing, the seal should be replaced. The seals are generally damaged upon removal.

Since the wheel bearings are made to extremely close tolerances, the clearance cannot normally be measured. Wash the bearing with a high flash-point solvent, dry it (**do not spin it while it is dry**), and oil it. Spin it by hand to check its condition. If it is noisy, does not spin smoothly, or has any rough spots, it must be replaced. If the same bearing is to be used again, re-wash it with a high flash-point solvent, dry it, and pack it with good quality bearing grease before installation. Turn the bearing by hand a few times to make sure the grease is distributed uniformly inside the bearing, and wipe the old grease out of the hub before bearing installation. Clean and grease the wheel bearings and

Table J6. Grease Seals, Wheel Bearings

| | Front Wheel | | | Rear Wheel | | |
|-------------|-------------|-----------|--------------------------|------------|----------|-----------|
| | Hub Left | Hub Right | Speedometer Gear Housing | Coupling | Hub Left | Hub Right |
| Grease Seal | — | PJ223508 | PJ304208 | PJN35527 | — | PJ254708 |
| Bearing | #6202Z | #6202Z | — | #6205 | #6303Z | #6303Z |

the front hub gear housing in accordance with the Periodic Maintenance Chart (Pg. 10).

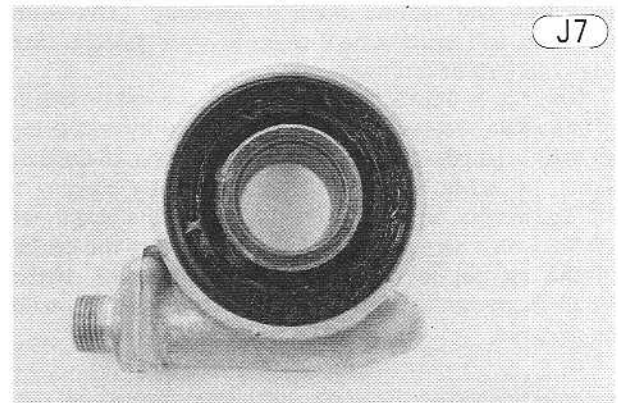
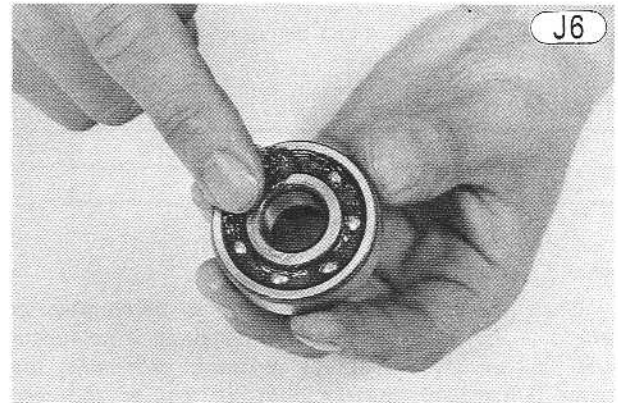

Rear Wheel Coupling

Damper inspection

Remove the rear wheel coupling (Pg. 99), and inspect the rubber damper.

Replace the damper if it appears to be damaged or deteriorated.

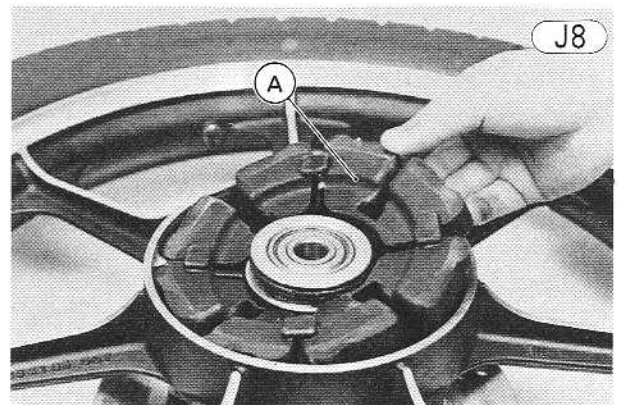

A. Rubber Damper

DRIVE CHAIN

The drive system was designed for use with the standard chain. For maximum strength and safety, the standard chain must be used for replacement.

Table J7 Drive Chain

| Make | Type | Link |
|-------|-----------|---------|
| Enuma | EK530SH-G | 98 link |

Wear

When the drive chain has worn so much that its length is 2% longer than the original, it is no longer safe for use and should be replaced. Whenever the chain is replaced, inspect both the engine and rear sprockets, and replace them if necessary. Overworn sprockets will cause a new chain to wear quickly. See page 145 ("sprockets" section).

Since it is impractical to measure the entire length of the chain, determine the degree of wear by measuring a 20-link length of the chain. Stretch the chain taut either by using the chain adjuster, or by hanging a 10 kg weight on the chain. Measure the length of 20 links on a straight part of the chain from the center of the 1st pin to the center of the 21st pin. If the length is greater than the service limit, the chain should be replaced.

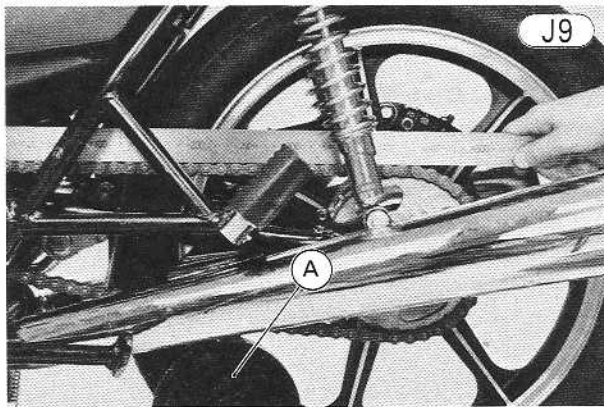

A. Weight

Drive Chain

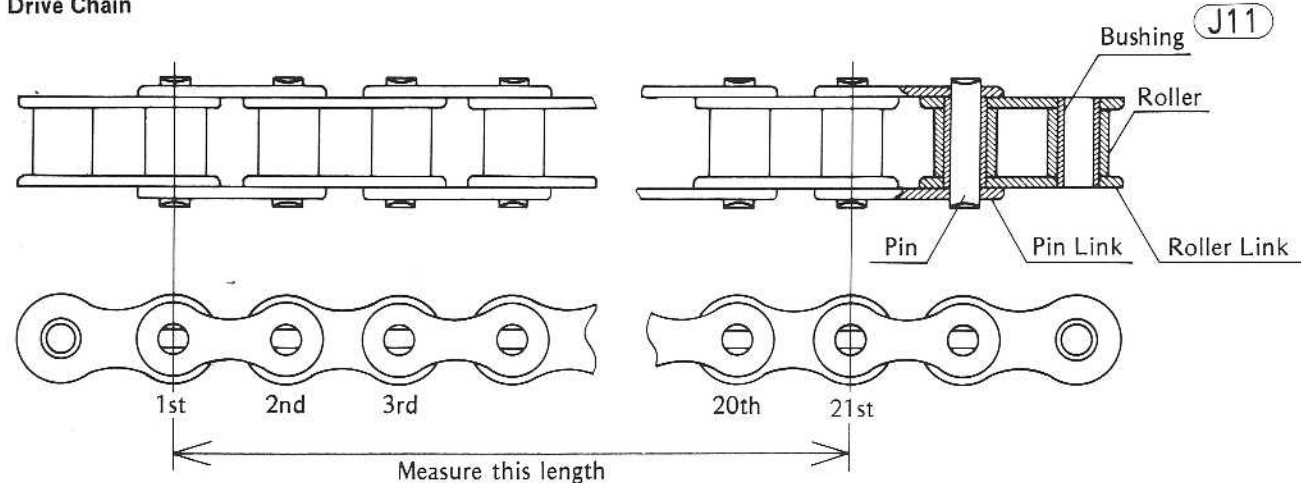

Table J8 Drive Chain 20-link Length

| Standard | Service Limit |
|----------------|---------------|
| 317.5~318.1 mm | 323 mm |

Lubrication

In order for the chain to function safely and wear slowly, it should be properly lubricated in accordance with the Periodic Maintenance Chart (Pg. 10). Lubrication is also necessary after riding through rain or on wet roads, or any time that the chain appears dry. Anytime that the motorcycle has been washed, the chain should be immediately lubricated to avoid rust.

The chain should be lubricated with a lubricant which will both prevent the exterior from rusting and also absorb shock and reduce friction in the interior of the chain. An effective, good quality lubricant specially formulated for chains is best for regular chain lubrication. If a special lubricant is not available, a heavy oil such as SAE 90 is preferred to a lighter oil because it will stay on the chain longer and provide better lubrication. Apply the oil to the sides of the rollers and between the side plates of the links so that oil will penetrate to the pins and bushings where most wear takes place. Wipe off any excess oil.

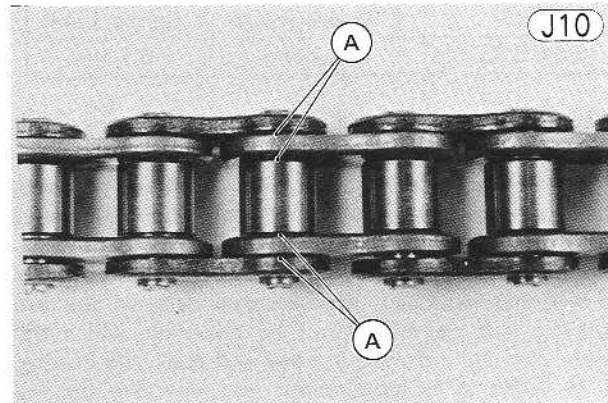

A. Oil

Dirt will cling to the oil and act as an abrasive, accelerating chain wear. Whenever the chain becomes particularly dirty, it must be cleaned in kerosene and

then soaked in a heavy oil. Shake the chain while it is in the oil so that oil will penetrate to the inside of the rollers.

SPROCKETS

Sprocket wear

Visually inspect the sprocket teeth. If they are worn as illustrated, replace the sprocket.

Measure the diameter of the sprocket at the base of the teeth. If the sprocket is worn down to less than the service limit, replace the sprocket.

Sprocket Teeth

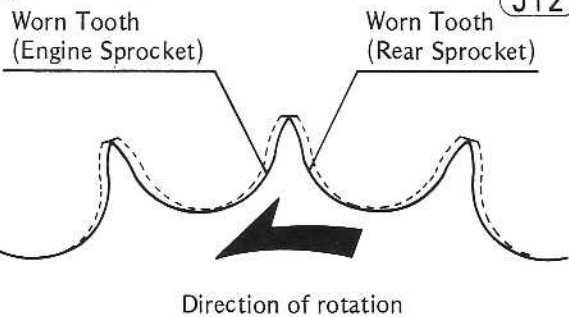

NOTE: If a sprocket requires replacement, the chain is probably worn also. Upon replacing a sprocket, inspect the chain.

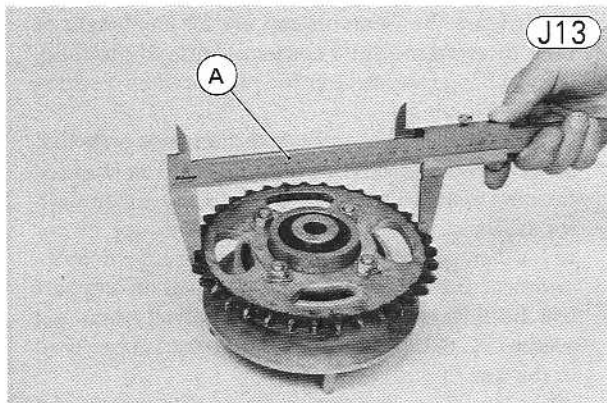

A. Vernier Calipers

Table J9 Sprocket Diameter

| | Standard | Service Limit |
|--------|------------------|---------------|
| Engine | 65.58~65.78 mm | 64.9 mm |
| Rear | 166.81~167.31 mm | 166.5 mm |

Rear sprocket warp

Elevate the rear wheel so that it will turn freely, and set a dial gauge against the rear sprocket near the teeth as shown in Fig. J14. Rotate the rear wheel. The difference between the highest and lowest dial gauge readings is the amount of runout (warp).

If the runout exceeds the service limit, replace the rear sprocket.

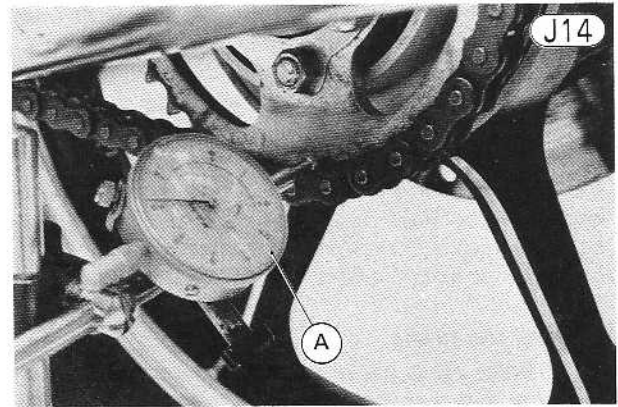

A. Dial Gauge

Table J10 Rear Sprocket Warp

| Standard | Service Limit |
|--------------|---------------|
| under 0.4 mm | 0.5 mm |

BRAKES

Brake Fluid

Changing the brake fluid

The brake fluid should be changed in accordance with the Periodic Maintenance Chart (Pg. 10) and whenever it becomes contaminated with dirt or water.

- Attach a clear plastic hose to the bleed valve on the caliper, and run the other end of the hose into a container.
- Remove the reservoir cap, and remove the rubber cap on the bleed valve.
- Open the bleed valve (counterclockwise to open), and pump the brake lever or pedal until all the fluid is drained from the line.

Filling Up the Brake Line

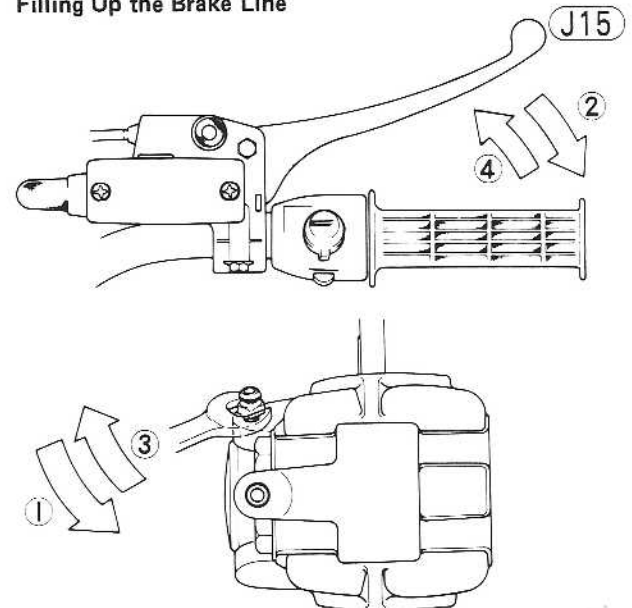

1. Open the bleed valve.
2. Apply the brake, keeping the brake applied.
3. Close the bleed valve.
4. Then quickly release the brake.

- Close the bleed valve, and fill the reservoir with fresh brake fluid.
- Open the bleed valve, apply the brake by the brake lever or pedal, close the valve with the brake held applied, and then quickly release the lever or pedal. Repeat this operation until the brake line is filled and fluid starts coming out of the plastic hose. Replenish the fluid in the reservoir as often as necessary to keep it from running completely out.
- Bleed the air from the lines.

Bleeding the brake

The brake fluid has a very low compression coefficient so that almost all the movement of the brake lever or pedal is transmitted directly to the caliper for braking action. Air, however, is easily compressed. When air enters the brake lines, brake lever or pedal movement will be partially used in compressing the air. This will make the lever or pedal feel spongy, and there will be a loss in braking power.

Bleed the air from the brake whenever brake lever or pedal action feels soft or spongy, after the brake fluid is changed, or whenever a brake line fitting has been loosened for any reason.

- Remove the reservoir cap, and check that there is plenty of fluid in the reservoir. The fluid level must be checked several times during the bleeding operation and replenished as necessary. If the fluid in the reservoir runs completely out any time during bleeding, the bleeding operation must be done over again from the beginning since air will have entered the line.

- With the reservoir cap off, slowly pump the brake lever or pedal several times until no air bubbles can be seen rising up through the fluid from the holes at the bottom of the reservoir. This bleeds the air from the master cylinder end of the line.

Bleeding the Brake Line

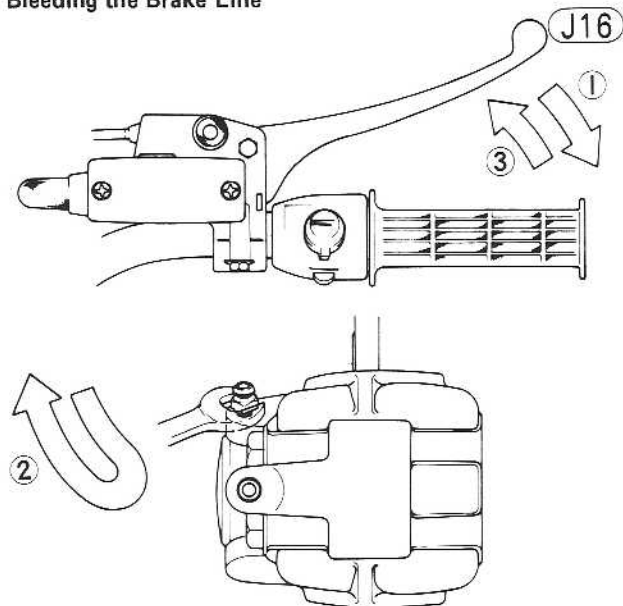

1. Hold the brake applied.
2. Quickly open and close the valve.
3. Release the brake.

WARNING

When working with the disc brake, observe the precautions listed below.

1. Never reuse old brake fluid.
2. Do not use fluid from a container that has been left unsealed or that has been open for a long time.
3. Do not mix two types of fluid for use in the brake. This lowers the brake fluid boiling point and could cause the brake to be ineffective. It may also cause the rubber brake parts to deteriorate. Recommended fluids are given in the table. **NOTE:** The type of fluid originally used in the disc brake is not available in most areas, but it should be necessary to add very little fluid before the first brake fluid change. After changing the fluid, use only the same type thereafter.

Table J11 Recommended Disc Brake Fluid

| |
|----------------------------|
| Atlas Extra Heavy Duty |
| Shell Super Heavy Duty |
| Texaco Super Heavy Duty |
| Wagner Lockheed Heavy Duty |
| Castrol Girling-Green |
| Castrol GT (LMA) |
| Castrol Disc Brake Fluid |

The correct fluid will come in a can labeled D.O.T.3. Do not use fluid that does not have this marking.

4. Don't leave the reservoir cap off for any length of time to avoid moisture contamination of the fluid.
5. Don't change the fluid in the rain or when a strong wind is blowing.
6. Except for the disc pads and discs, use only disc brake fluid, isopropyl alcohol, or ethyl alcohol for cleaning brake parts. Do not use any other fluid for cleaning these parts. Gasoline, motor oil, or any other petroleum distillate will cause deterioration of the rubber parts. Oil spilled on any part will be difficult to wash off completely and will eventually reach and break down the rubber used in the disc brake.
7. When handling the disc pads or disc, be careful that no disc brake fluid or any oil gets on them. Clean off any fluid or oil that inadvertently gets on the pads or disc with a high flash-point solvent. Do not use one which will leave an oily residue. Replace the pads with new ones if they cannot be cleaned satisfactorily.
8. Brake fluid quickly ruins painted surfaces; any spilled fluid should be completely wiped up immediately.
9. If any of the brake line fittings or the bleed valve is opened at any time, the **AIR MUST BE BLED FROM THE BRAKE.**
10. When installing or assembling the disc brake, tighten the disc brake fittings to the values given in Table G1. Improper torque may cause the brake to malfunction.

- Install the reservoir cap, and connect a clear plastic hose to the bleed valve at the caliper, running the other end of the hose into a container. Pump the brake lever or pedal a few times until it becomes hard and then, holding the lever squeezed or the pedal pushed down, quickly open (turn counterclockwise) and close the bleed valve. Then release the lever or pedal. Repeat this operation until no more air can be seen coming out into the plastic hose. Check the fluid level in the reservoir every so often, replenishing it as necessary.
- When air bleeding is finished, install the rubber cap on the bleed valve, and check that the brake fluid is filled to the level line in the reservoir.

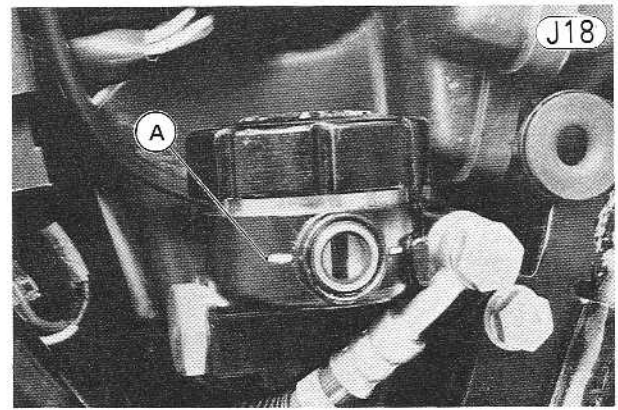

A. Rear Master Cylinder

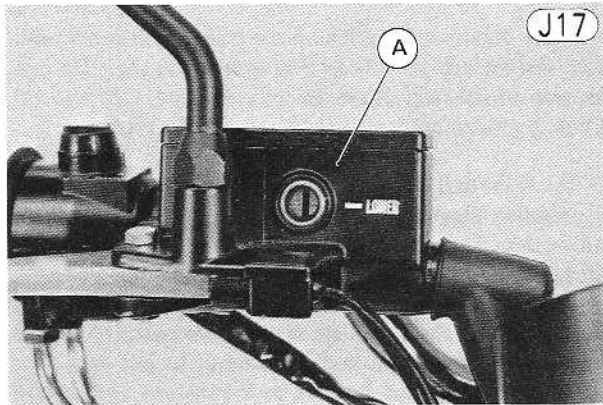

A. Front Master Cylinder

Master cylinder parts wear

When master cylinder parts are worn or damaged, proper brake fluid pressure cannot be obtained in the line, and the brake will not hold.

If the small relief port becomes plugged, especially with a swollen or damaged primary cup, the brake pads will drag on the disc.

- Check that there are no scratches, rust or pitting on the inside of the master cylinder, and that it is not worn past the service limit.
- Check the piston for these same faults.
- Inspect the primary and secondary cups. If a cup is worn, damaged, softened (rotted), or swollen, replace

Master Cylinder

J19

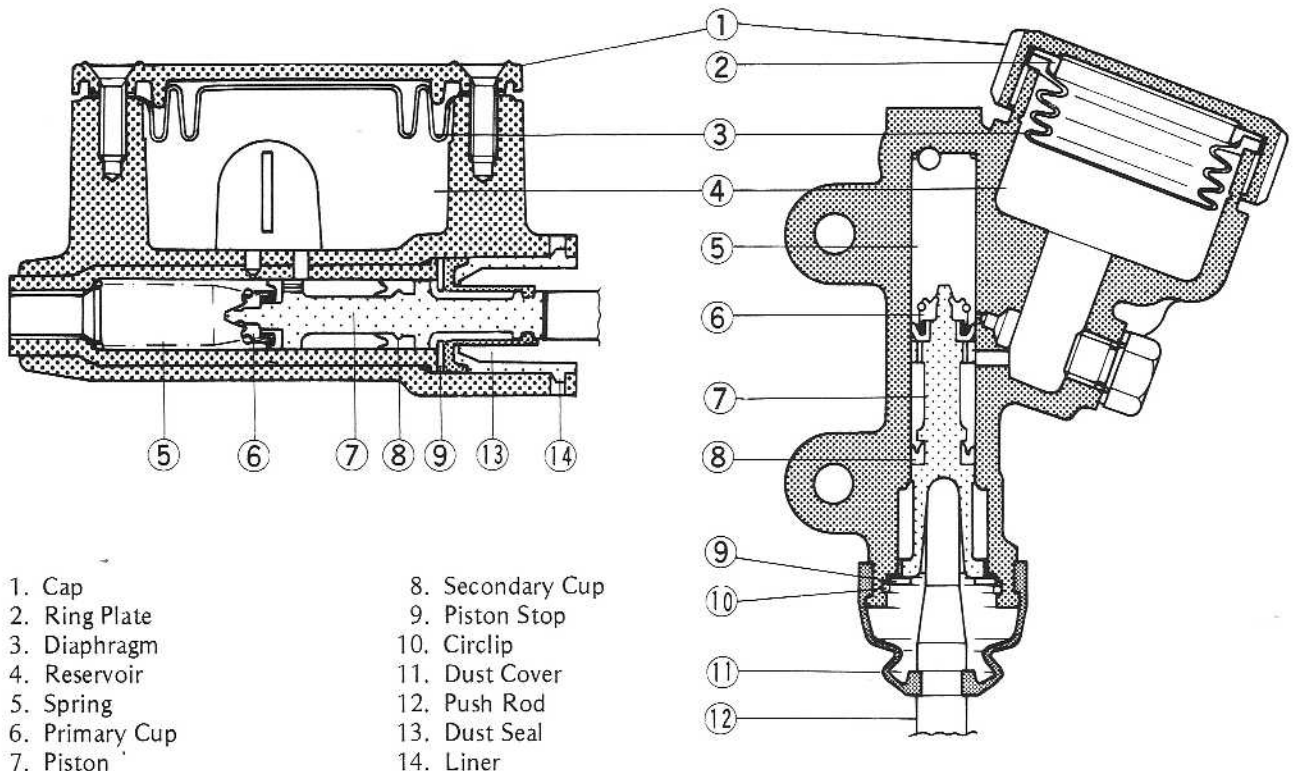

Table J12 Master Cylinder Parts

| | | Standard | Service Limit |
|-------|--------------------------|------------------|---------------|
| Front | Cylinder Inside Diameter | 14.000~14.063 mm | 14.08 mm |
| | Piston Outside Diameter | 13.957~13.984 mm | 13.90 mm |
| | Primary Cup Diameter | 14.2~14.6 mm | 14.0 mm |
| | Secondary Cup Diameter | 14.65~15.15 mm | 14.50 mm |
| | Spring Free Length | 42.8~46.8 mm | 40.7 mm |
| Rear | Cylinder Inside Diameter | 14.000~14.043 mm | 14.08 mm |
| | Piston Outside Diameter | 13.957~13.984 mm | 13.90 mm |
| | Primary Cup Diameter | 14.65~15.15 mm | 14.5 mm |
| | Secondary Cup Diameter | 14.65~15.15 mm | 14.5 mm |
| | Spring Free Length | 48.7~52.7 mm | 46.3 mm |

it. When inserting the cup into the cylinder, see that it is slightly larger than the cylinder (standard values given in the table). If fluid leakage is noted at the brake lever or pedal, the cups should be replaced. (The secondary cup is part to the piston assembly. Replace the piston if the secondary cup requires replacement).

If any grease or oil spills on the pads, wash it off with trichloroethylene or a high flash-point solvent. Do not use one which will leave an oily residue. If the oil cannot be thoroughly clean off, replace the pads.

The fluid seal around the piston maintains the proper pad/disc clearance. If this seal is not satisfactory, pad wear will increase, and constant pad drag on the disc will raise brake and brake fluid temperature.

Replace the fluid seals under any of the following conditions: (a) fluid leakage around the pad; (b) brakes overheat; (c) there is a large difference in left and right pad wear; (d) the seal is stuck to the piston. If the fluid seal is replaced, replace the dust seal as well. Also, replace all seals every other time the pads are changed.

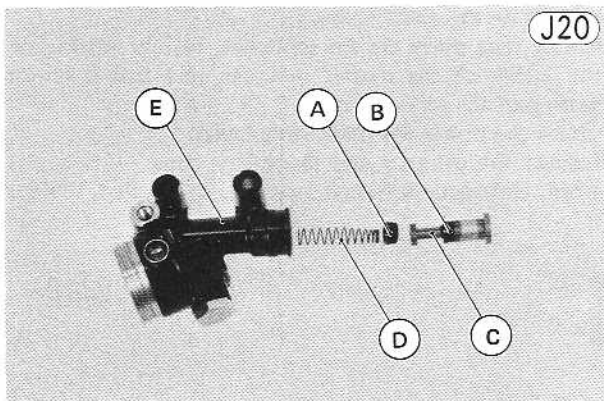

J20

A. Primary Cup C. Piston
B. Secondary Cup

- Check that the spring is not damaged and is not shorter than the service limit.
- Replace the dust seal if damaged.



J22

A. Stepped Portion

Rear Disc Brake Pad

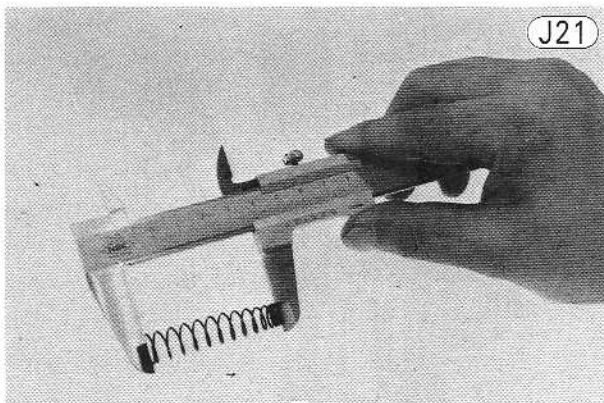

J21

Caliper parts wear

Inspect the pads for wear. If either of the left and right pads is worn down through the stepped portion, or thickness of it is less than 1 mm, replace both pads as a set.

J23

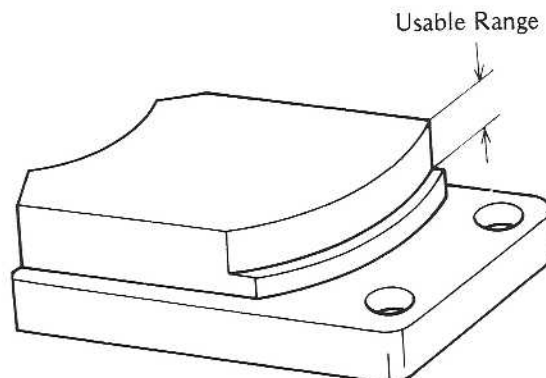

Check the dust seals, dust covers, and O rings, and replace any that are cracked, worn, swollen or otherwise damaged.

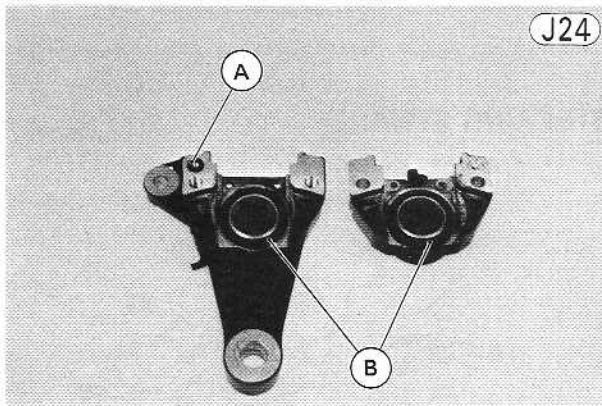

A. O Rings

B. Dust Seals

Calipers

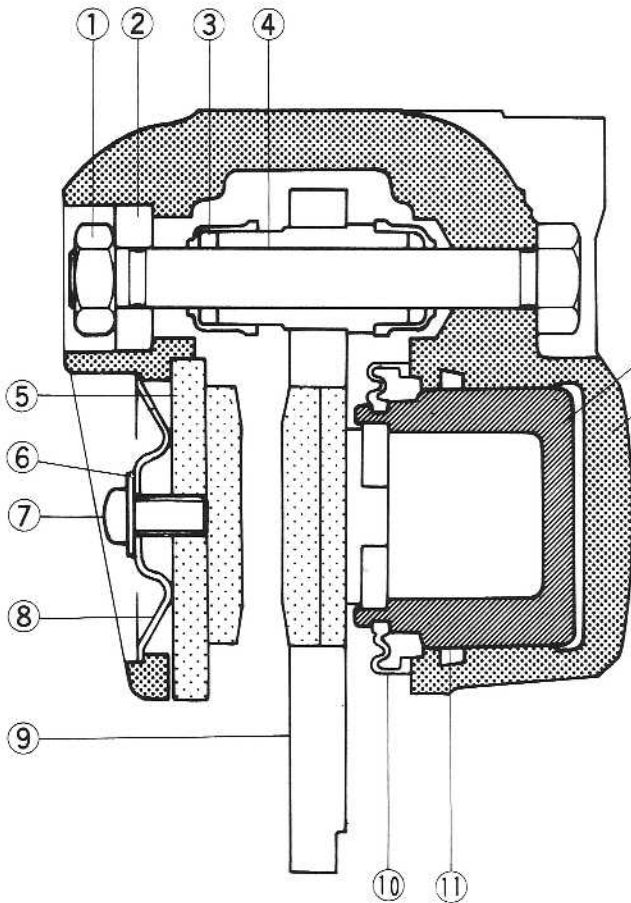

- 1. Nut
- 2. Spacer
- 3. Dust Cover
- 4. Holder Shaft
- 5. Pad
- 6. Lockwasher
- 7. Screw
- 8. Metal Plate
- 9. Caliper Holder

- 10. Dust Seal
- 11. Fluid Seal
- 12. Bleed Valve Cap
- 13. Anti-rattle Spring
- 14. Pin
- 15. Pad Cover
- 16. Bleed Valve
- 17. Piston
- 18. Caliper

Measure the cylinder inside diameter and piston outside diameter.

Replace the cylinder and piston if they are worn out of tolerance, badly scored, or rusty.

Table J13 Caliper Parts

| | | Standard | Service Limit |
|----------------------|-------|------------------|---------------|
| Cylinder Inside Dia. | Front | 42.850~42.900 mm | 42.92 mm |
| | Rear | 38.180~38.230 mm | 38.25 mm |
| Piston Outside Dia. | Front | 42.788~42.820 mm | 42.75 mm |
| | Rear | 38.116~38.148 mm | 38.08 mm |

Caliper holder shafts must slide smoothly in the caliper holder. If the shafts do not slide smoothly, one pad will wear more than the other, pad wear will increase, and constant drag on the disc will raise brake and brake fluid temperature. Check to see if the caliper holder shafts are not badly worn or stepped. If the

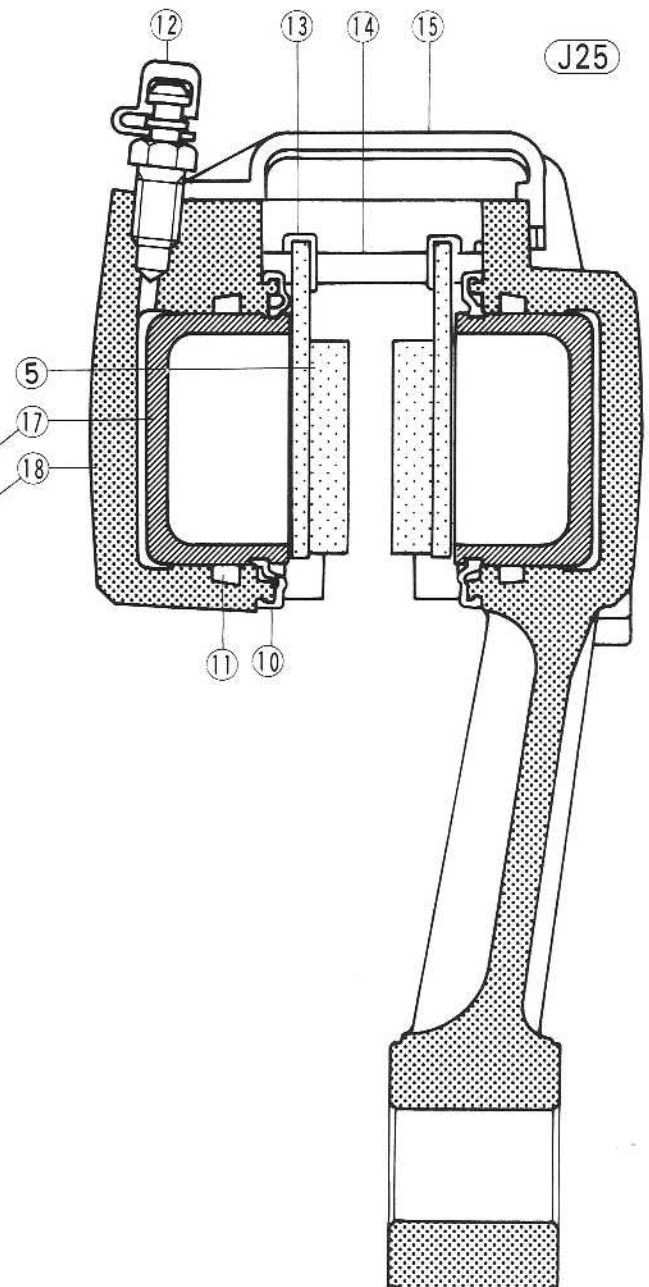

150 MAINTENANCE—CHASSIS

shafts are damaged, replace the shafts and the caliper holder.

Brake line damage

The high pressure inside the brake line can cause fluid to leak or the hose to burst if the line is not properly maintained.

Bend and twist the rubber hose while examining it. Replace it if any cracks or bulges are noticed.

Disc wear, warp

Besides wearing down, the disc may warp. A warped disc will cause the brake pads to drag on the disc and will wear down both the pads and disc quickly. Dragging will also cause overheating and poor braking efficiency. Poor braking can also be caused by oil on the disc. Oil on the disc must be cleaned off with trichloroethylene or a high flash-point solvent. Do not use one which will leave an oily residue.

Jack up the motorcycle so that the front wheel is off the ground, and turn the handlebar fully to one side. Set up a dial gauge against the front disc as illustrated, and measure disc runout. Remove the jack, set the motorcycle up on its center stand, and then measure the rear disc runout. If runout exceeds the service limit, replace the disc.

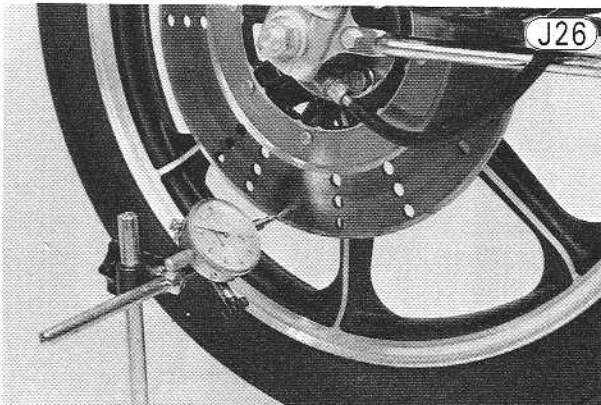

Table J14 Disc Runout (Front, Rear)

| Standard | Service Limit |
|---------------|---------------|
| under 0.15 mm | 0.3 mm |

Measure the thickness of each disc at the point where it has worn the most. Replace the disc if it has worn past the service limit.

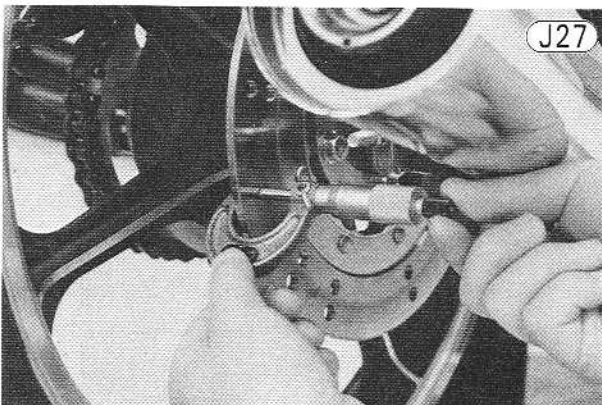
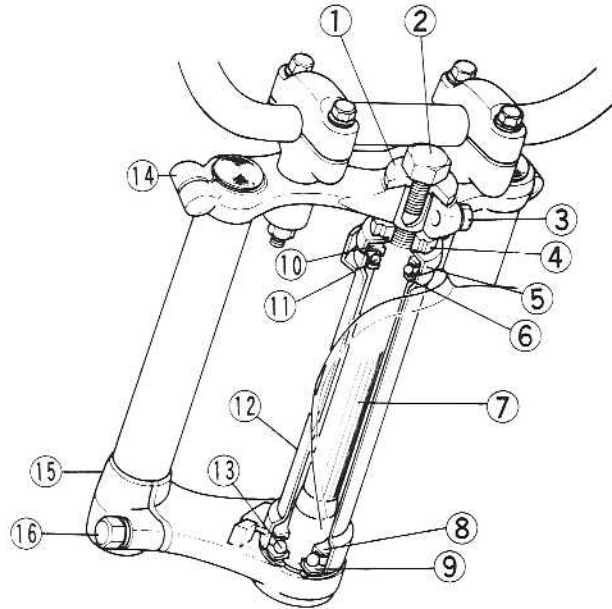

Table J15 Disc Thickness

| Standard | Service Limit |
|------------|---------------|
| 4.8~5.1 mm | 4.5 mm |

STEERING STEM

(J28)



- | | |
|-------------------------|----------------------|
| 1. Flat Washer | 9. Lower Inner Race |
| 2. Stem Head Bolt | 10. Upper Inner Race |
| 3. Stem Head Clamp Bolt | 11. Bearing Ball |
| 4. Stem Locknut | 12. Frame Head Pipe |
| 5. Stem Cap | 13. Bearing Ball |
| 6. Upper Outer Race | 14. Stem Head |
| 7. Steering Stem | 15. Stem Base |
| 8. Lower Outer Race | 16. Clamp Bolt |

Table J16 Bearing Ball Specifications

| Size | Quantity |
|------|----------|
| 1/4" | 19 x 2 |

Steering stem warp

Examine the steering stem, and replace it if it is bent.

Bearing wear, damage

Wipe the bearings clean of grease and dirt, and examine the races and balls. If the balls or races are worn, or if either race is dented, replace both races and all the balls for that bearing as a set.

Bearing lubrication

In accordance with the Periodic Maintenance Chart (Pg. 10), and whenever the steering stem is disassembled, the steering stem bearings should be relubricated.

Wipe all the old grease off the races and balls, washing them in a high flash-point solvent if necessary. Replace the bearing parts if they show wear or damage. Apply grease liberally to the upper and lower races, and stick the bearing balls in place with grease.

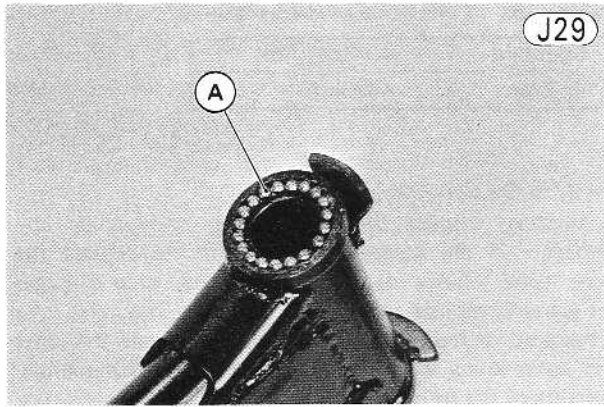

A. Bearing Balls

FRONT FORK

Either too much or too little oil in the fork legs will adversely affect shock damping. Too much oil or too heavy oil makes the action too stiff; too little oil or too light oil makes the action soft, decreases damping potential, and may cause noise during fork movement.

Contaminated or deteriorated oil will also affect shock damping and, in addition, will accelerate internal wear. The fork oil should be changed periodically (Pg. 10) or sooner if the oil appears dirty.

A bent, dented, scored, or otherwise damaged inner tube will damage the oil seal, causing oil leakage. A badly bent inner tube may cause poor handling.

Fork oil level

To check the fork oil level, first place a jack or stand under the engine so that the front wheel is raised off the ground. Remove the top plug and pull out the spring from the inner tube. Insert a rod down into the tube, and measure the distance from the top of the inner tube to the oil level. If the oil is below the correct level, add enough oil to bring it up to the proper level, taking care not to overfill.

Fork Oil Level

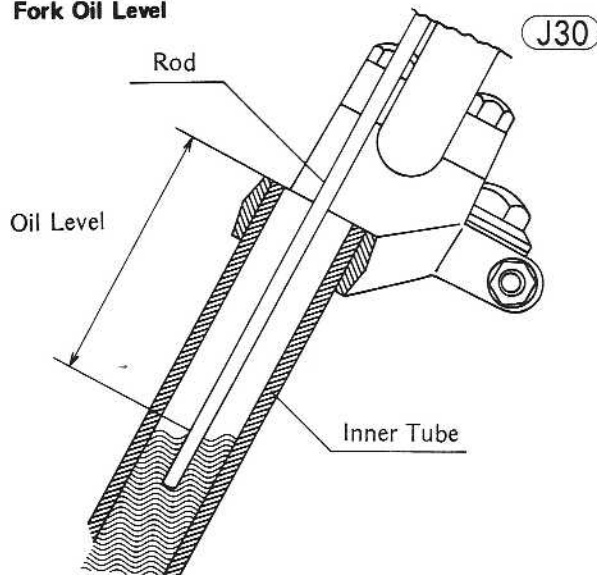

Front Fork

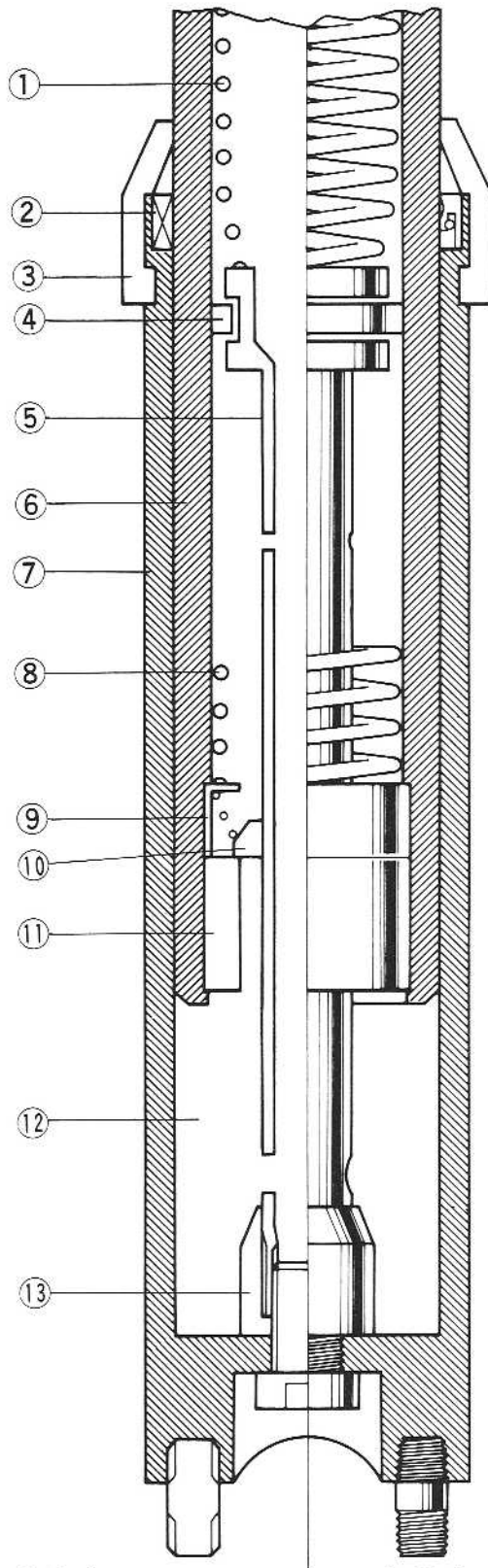

- | | |
|----------------|----------------------|
| 1. Spring | 8. Spring |
| 2. Oil Seal | 9. Valve Seat |
| 3. Dust Seal | 10. Non-return Valve |
| 4. Piston Ring | 11. Collar |
| 5. Piston | 12. Lower Chamber |
| 6. Inner Tube | 13. Cylinder Base |
| 7. Outer Tube | |

152 MAINTENANCE—CHASSIS

Fork oil change

To drain out the old oil, remove the drain bolt from the lower end of the outer tube. With the front wheel on the ground and the front brake fully applied, push down on the handlebar a few times to pump out the oil. Install the drain bolt.

Remove the top plug and pull out the spring from the inner tube. Pour in the type and amount of oil specified in Table J16, and check the oil level. If the oil is below the specified level, add oil and re-check the oil level.

NOTE: After the front fork oil is changed and before checking the oil level, pump the forks several times to expel air from the upper and lower chambers.

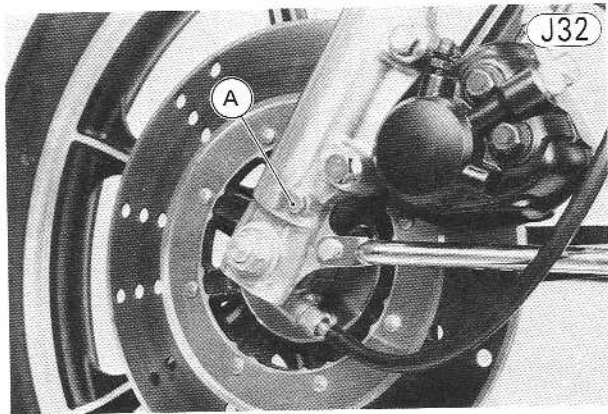
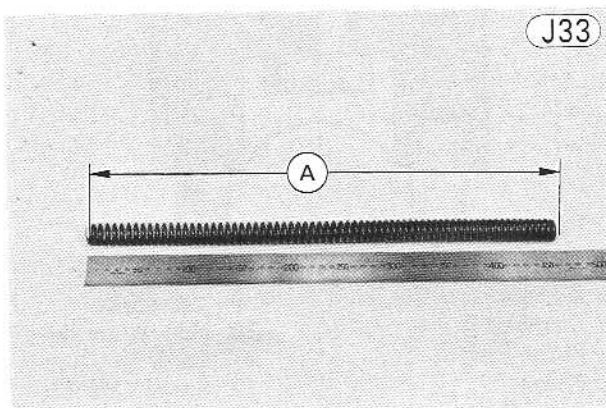

Table J17 Fork Oil

| Type | Capacity | Oil Level |
|----------|----------|-----------------------------------|
| SAE 5W20 | 150 cc | 440 ± 2 mm from top of inner tube |

Spring tension

Since the spring becomes shorter as it weakens, check its free length to determine its condition. If the spring of either fork leg is shorter than the service limit, it must be replaced. If the difference of both old and new spring length is great, the old spring should also be replaced in order to keep the fork leg balanced for motorcycle stability.



A. Free Length

Table J18 Fork Spring Free Length

| Standard | Service Limit |
|----------|---------------|
| 452 mm | 442 mm |

Inner tube damage

Visually inspect the inner tube, and repair any damage. If the damage is not repairable, replace the inner tube. Since damage to the inner tube damages the oil seal, replace the oil seal whenever the inner tube is repaired or replaced. Temporarily assemble the inner and outer tubes, and pump them back and forth manually to check for smooth operation.

CAUTION If the inner tube is bent or badly creased, replace it. Excessive bending, followed by subsequent straightening, can weaken the inner tube.

SWING ARM

Swing arm bearing wear

Measure the outside diameter of the swing arm sleeve at both ends with a micrometer. Replace the swing arm sleeve if the diameter is less than the service limit or if it shows visible damage.

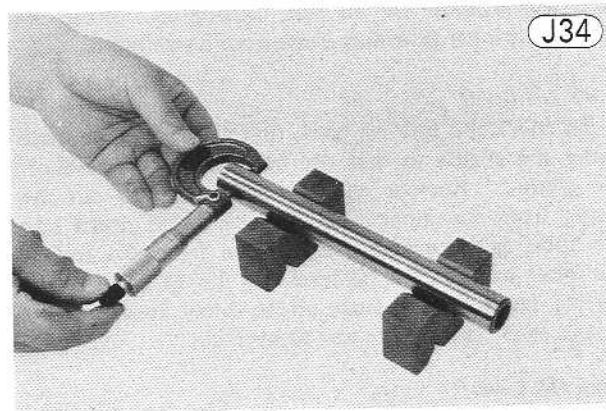

Table J19 Swing Arm Sleeve Diameter

| Standard | Service Limit |
|------------------|---------------|
| 21.987~22.000 mm | 21.96 mm |

The rollers in the needle bearings wear so little that the wear is difficult to measure. Instead, inspect the needle bearings for abrasions, color change, or other damage. If there is any doubt as to the condition of any needle bearing, replace all the needle bearings. Whenever the swing arm sleeve is replaced, also replace the needle bearings.

Pivot shaft

To measure the pivot shaft runout, set the pivot shaft on V blocks at the ends of the shaft, and set a dial gauge

to the shaft halfway between the blocks. Turn the shaft to measure the runout. The amount of runout is the amount of dial variation. If the shaft runout exceeds the Usable Range, straighten it within usable range. If it cannot be straightened, or if the runout exceeds the service limit, replace the shaft.

Pivot Shaft Runout

J35

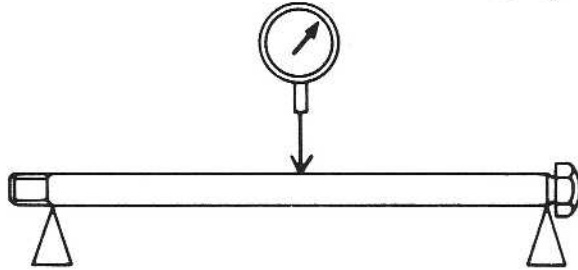

Table J20 Pivot Shaft Runout

| Standard | Usable Range | Service Limit |
|---------------|--------------|---------------|
| under 0.10 mm | 0.14 mm | 0.7 mm |

Swing arm lubrication

There is a grease nipple on the swing arm for lubrication. Grease the swing arm with regular cup grease with the frequency given in the Periodic Maintenance Chart (Pg. 10). Force the grease into the nipple until it comes out at both sides of the swing arm, and wipe off any excess.

Swing Arm

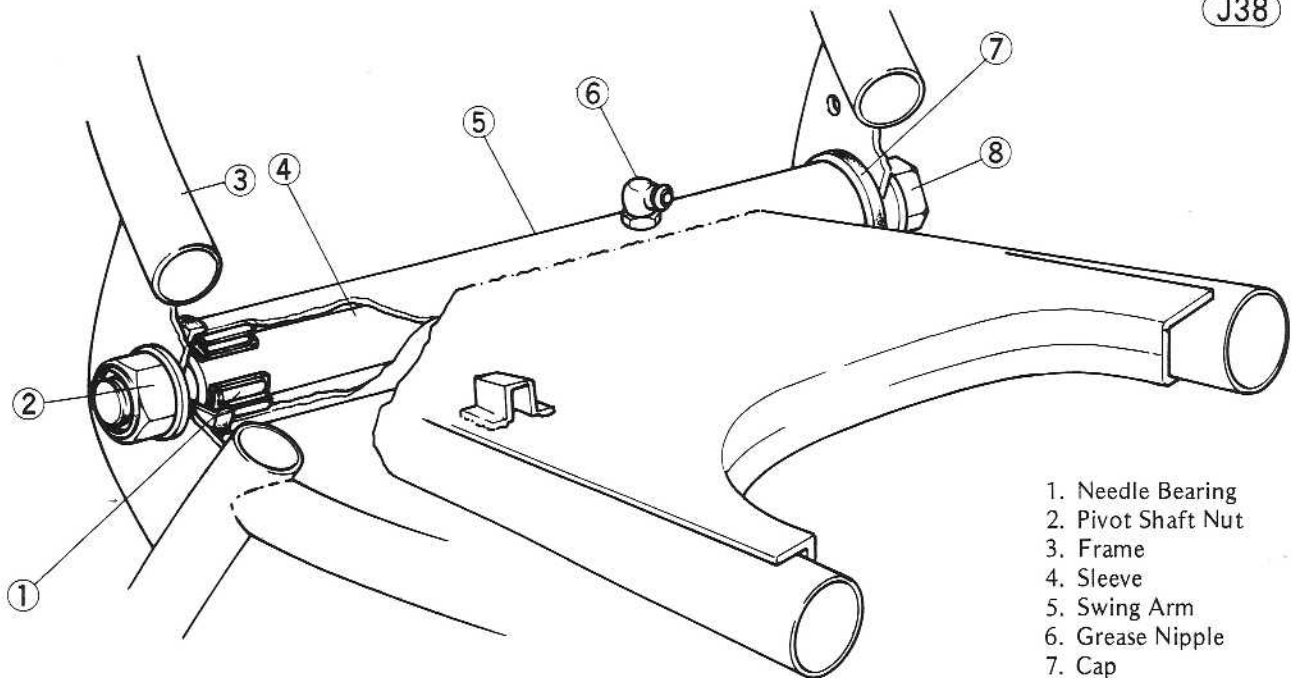

- 1. Needle Bearing
- 2. Pivot Shaft Nut
- 3. Frame
- 4. Sleeve
- 5. Swing Arm
- 6. Grease Nipple
- 7. Cap
- 8. Pivot Shaft

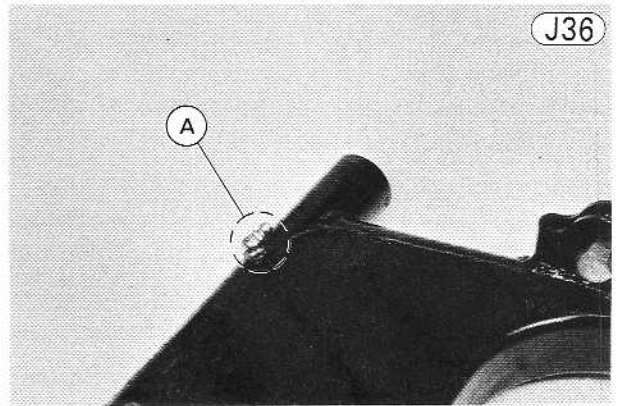

A. Grease Nipple

If the grease does not come out, first check that the nipple is not clogged with dirt or old grease. If the nipple is clear but still will not take grease; remove the swing arm, pull out the sleeve, clean out the old grease, and apply grease to the needle bearings.

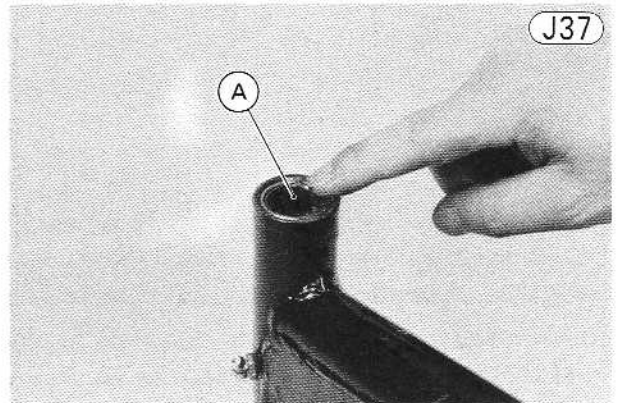

A. Needle Bearing

J38

Maintenance—Electrical

Table of Contents

| | |
|--------------------------------|-----|
| BATTERY | 156 |
| CHARGING SYSTEM | 158 |
| Alternator | 158 |
| Regulator/Rectifier | 159 |
| IGNITION SYSTEM | 160 |
| Ignition Coil | 161 |
| Contact Breaker | 161 |
| Capacitor | 162 |
| Timing Advancer | 162 |
| Spark Plugs | 163 |
| ELECTRIC STARTER SYSTEM | 164 |
| Starter Motor Circuit | 164 |
| Starter Motor | 164 |
| Starter Motor Clutch | 166 |
| IGNITION SWITCH | 166 |
| NEUTRAL INDICATOR SWITCH | 166 |
| LIGHTING SYSTEM | 167 |
| Headlight Circuit | 167 |
| Brake Light Circuit | 168 |
| Turn Signal Circuit | 169 |
| HORN | 170 |



BATTERY

1. When the level of the electrolyte in the battery is low, add only distilled water to each cell, until the level is at the upper level line marked on the outside of the battery. Ordinary tap water is not a substitute for distilled water and will shorten the life of the battery.
2. Never add sulphuric acid solution to the battery. This will make the electrolyte solution too strong and will ruin the battery within a very short time.
3. Avoid quick-charging the battery. A quick-charge will damage the battery plates.
4. Never let a good battery stand for more than 30 days without giving it a supplemental charge, and never let a discharged battery stand without charging it. If a battery stands for any length of time, it slowly self-discharges. Once it is discharged, the plates sulphate (turn white), and the battery will no longer take a charge.
5. Keep the battery well-charged during cold weather so that the electrolyte does not freeze and crack open the battery. The more discharged the battery becomes, the more easily it freezes.
6. Always keep the battery vent hose free of obstruction, and make sure it does not get pinched, crimped, or melted shut by contact with the hot muffler. If battery gases cannot escape through this hose, they will explode the battery.
7. **DON'T INSTALL THE BATTERY BACKWARDS.** The negative side is grounded.

Electrolyte

The electrolyte is dilute sulphuric acid. The standard specific gravity of the electrolyte used in warm climates in a fully charged battery is 1.260 at 20°C (68°F). (In particularly cold regions, a solution with a standard specific gravity of 1.280 is used). The water in this solution changes to a gaseous mixture due to chemical action in the battery and escapes, which concentrates the acid in a charged battery. Consequently, when the level of the electrolyte becomes low, only distilled water should be added. If sulphuric acid is added, the solution will damage the plates. Metal from the damaged plates collects in the bottom of the battery. This sediment will eventually cause an internal short circuit.

The specific gravity of the electrolyte is measured with a hydrometer and is the most accurate indication of the condition of the battery. When using the hydrometer, read the electrolyte level at the bottom of the meniscus (curved surface of the fluid). See Fig. K1. Fig. K2 shows the relationship between the specific gravity of the solution at 20°C (68°F) and the percentage of battery charge. Since specific gravity varies with temperature, and since the temperature of the solution being checked likely to be other than 20°C (68°F); the formula given below should be used to compute the equivalent specific gravity for any temperature. When the temperature goes up, the specific gravity goes down, and vice versa.

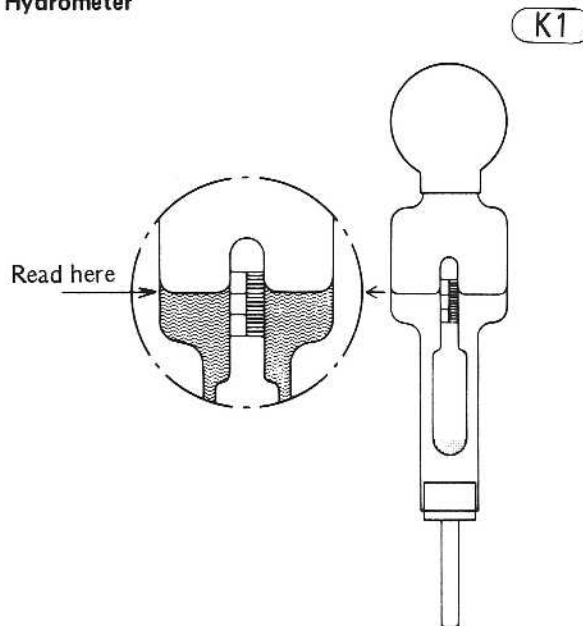
Hydrometer

○Celsius

$$S_{20} = S_t + [0.0007 (t-20)]$$

○Fahrenheit

$$S_{68} = S_t + [0.0004 (t-68)]$$

S_t = specific gravity at the present temperature

S_{20} = specific gravity at 20°C

S_{68} = specific gravity at 68°F

t = present temperature of solution

Generally speaking, a battery should be charged if a specific gravity reading shows it to be discharged to 50% or less of full charge.

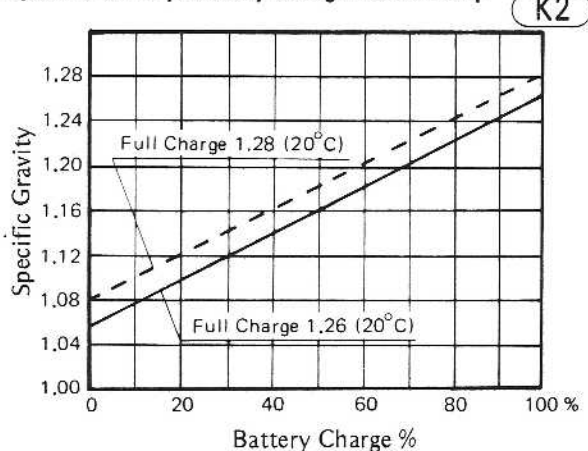
Specific Gravity/Battery Charge Relationship**Initial charge**

New batteries for Kawasaki motorcycles are dry charged and can be used directly after adding the electrolyte. However, the effect of the dry charge deteriorates somewhat during storage, especially if any air

has entered the battery from imperfect sealing. Therefore, it is best to give the battery an initial charge before using it in order to ensure long battery life.

WARNING Because the battery gives off an explosive gas mixture of hydrogen and oxygen, keep any sparks or open flame away from the battery during charging.

- Pour a 1.260 (specific gravity at 20°C or 68°F) sulphuric acid solution into each cell of the battery up to the upper level line.
- Let the battery stand for 30 minutes, adding more acid if the level drops during this time.

NOTES: 1. If the temperature of the solution is over 30°C (85°F), cool the solution before pouring it into the battery.

2. After pouring the acid into the battery, start charging the battery within 12 hours.

- Leaving the caps off the cells, connect the battery to a charger, set the charging rate at 1/10 the battery capacity, and charge it for 10 hours. For example, if the battery is rated at 10AH, the charging rate would be 1.0 ampere. If a constant voltage charger is used, the voltage must be adjusted periodically to keep the current at a constant value.

CAUTION If the temperature of the electrolyte rises above 45°C (115°F) during charging, reduce the charging rate to bring down the temperature, and increase the charging time proportionately.

- After charging, check the electrolyte level in each cell. If the level has dropped, add distilled water to bring it back up to the upper level line.
- Check the results of charging by measuring the specific gravity of each cell and by measuring battery voltage. Battery voltage of a 12 volt battery directly after the completion of charging should be 15 to 16 volts.

Ordinary charge

WARNING Because the battery gives off an explosive gas mixture of hydrogen and oxygen, keep any sparks or open flame away from the battery during charging.

- Clean off the battery using a solution of baking soda and water. Make especially sure that the terminals are clean.
- If the electrolyte level is low in any cell, fill to over the lower level line but not up to the upper level line since the level rises during charging. Figure the charging rate to be between 1/10 and 3/10 of battery capacity. For example, the maximum charging rate for a 10AH battery would be 3/10 x 10 which equals 3.0 amperes.

- Measure the specific gravity of the electrolyte, and use the graph, Fig. K2 to determine the percentage of discharge. Multiply the capacity of the battery by the percentage of discharge to find the amount of discharge in ampere-hours. Use this figure in the formula below to compute charging time.

$$\text{Charging (hours)} = \frac{\text{Amount of discharge (AH)}}{\text{charging current (A)}} \times 1.2 \sim 1.5$$

- Remove the caps from all the cells, and begin charging the battery at the rate just calculated. If a constant voltage charger is used, the voltage will have to be adjusted periodically to maintain charging current at a constant value.

CAUTION If the temperature of the electrolyte rises above 45°C (115°F) during charging, reduce the charging rate to bring down the temperature, and increase charging time proportionately.

- After charging, check the electrolyte level in each cell. If the level has dropped, add distilled water to bring it back up to the upper level line.
- Check charging results by measuring the specific gravity of each cell and by measuring battery voltage. Battery voltage of a 12 volt battery directly after the completion of charging should be 15 to 16 volts. If the voltage is lower than this, the battery is not completely charged or can no longer take a full charge.

Test charging

When the battery is suspected of being defective, first inspect the points noted in the Table below. The battery can be restored by charging it with the ordinary charge. If it will take a charge so that the voltage and specific gravity come up to normal, it may be considered good except in the following case:

- ★ If the voltage suddenly jumps to over 13 volts just after the start of charging, the plates are probably sulphated. A good battery will rise to 12 volts immediately and then gradually go up to 12.5 ~ 13 volts in about 30 to 60 minutes after charging is started.
- ★ If one cell produces no gas bubbles, or has a very low specific gravity, it is probably shorted.
- ★ If there does not appear to be enough sediment to short the plates, but one cell has a low specific gravity after the battery is fully charged, the trouble may be just that there is insufficient acid in that cell. In this instance only, sulphuric acid solution may be added to correct the specific gravity.

Table K1 Battery Troubleshooting Guide

| | Good Battery | Suspect Battery | Action |
|-------------------|--|---|----------------------|
| Plates | (+) chocolate color (-) gray | white (sulphated); + plates broken or corroded | Replace |
| Sediment | none, or small amount | Sediment up to plates, causing short | Replace |
| Voltage | above 12 volts | below 12 volts | Test charge |
| Electrolyte Level | above plates | below top of plates | Fill and test charge |
| Specific Gravity | above 1.200 in all cells; no two cells more than 0.020 different | below 1.100, or difference of more than 0.020 between two cells | Test charge |

★ If a fully charged battery not in use loses its charge after 2 to 7 days, or if the specific gravity drops markedly, the battery is defective. The self-discharge rate of a good battery is only about 1% per day.

CHARGING SYSTEM

Charging System

K3

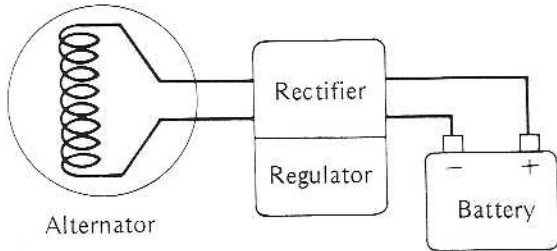

There are a number of important precautions that are musts when servicing the charging system. Cautions that are applied to the individual sections are mentioned each section. Failure to observe these rules can result in serious system damage. Learn and observe all the rules in each section.

When there are any problem indications in the charging system, give the system a quick initial inspection or check before starting a series of time consuming tests, or worse yet, removing parts for repair or replacement. Such a check will often turn up the source of the trouble.

Make sure all connectors in the circuit are clean and tight. Examine wires for signs of burning, fraying, etc. Poor wires and bad connections will affect electrical system operation. Check the alternator and regulator/rectifier for evidence of physical damage.

A worn out or badly sulphated battery will produce numerous problems that cannot be corrected until the battery is replaced. **ALWAYS CHECK BATTERY CONDITION BEFORE CONDEMNING OTHER PARTS OF THE SYSTEM. A FULLY CHARGED BATTERY IS A MUST FOR CONDUCTING ACCURATE SYSTEM TESTS.**

Charging system malfunctions can be traced to either the battery, alternator, regulator/rectifier, or the wiring. Troubles may involve one unit or in some cases, all units. Never replace a defective unit without determining what **CAUSED** the failure. If the failure was brought on by some other unit or units, they too must be repaired or replaced, or the new replacement will soon fail.

Initial inspection

Before making this test, check the condition of the battery (Pg. 156). If the battery voltage is less than 12 volts, charge the battery. Before starting the charging voltage test, warm up the engine to obtain actual alternator operating conditions.

- Lift up the seat.
- Set the multimeter to the 20V DC range, and connect the meter + lead to the battery + terminal and the meter - lead to the battery - terminal.

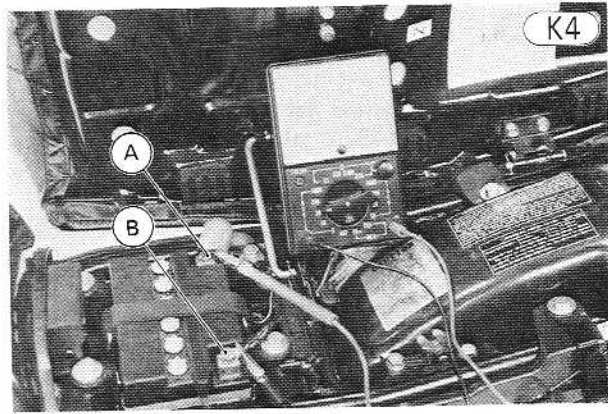

A. Battery (+) Terminal B. Battery (-) Terminal

●Start the engine, and run the engine at the rpm in Table K2. Note the voltage reading.

Table K2 Charging Voltage

| Meter | Connections | Reading @4,000 rpm |
|--------|--|--------------------|
| 20V DC | Meter (+) ↔ Battery (+) Meter (-) ↔ Battery (-) | about 14.5V |

●If the reading is more than 16V, the regulator/rectifier is defective, and should be replaced with a new one. If the reading is less than 14V, check the alternator output (Pg. 159) and regulator/rectifier (Pg. 159) to determine which part is defective.

Alternator

Alternator Construction

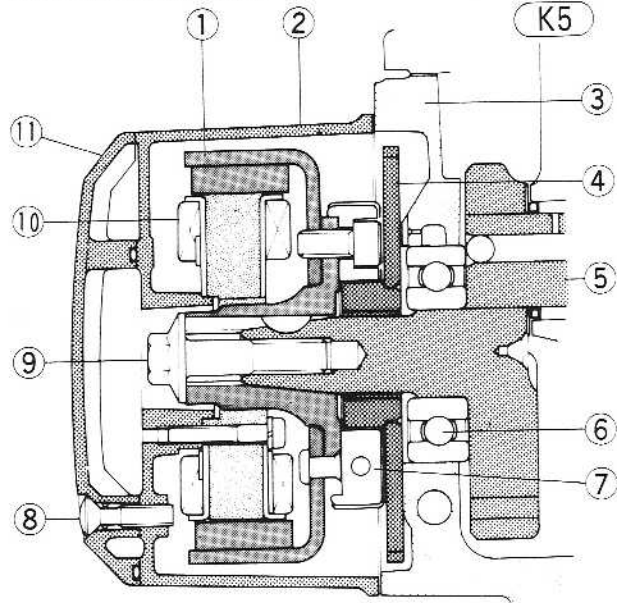

- | | |
|----------------------|----------------------|
| 1. Alternator Rotor | 7. Starter Clutch |
| 2. Left Engine Cover | 8. Screw |
| 3. Crankcase | 9. Rotor Bolt |
| 4. Starter Idle Gear | 10. Stator |
| 5. Crankshaft | 11. Alternator Cover |
| 6. Ball Bearing | |

Alternator failure

If the battery, regulator/rectifier, leads, and connectors are all good, but there is still low voltage or insufficient charging current, the alternator may be defective. There are three types of alternator failures: short, open (wire burned out), or loss in rotor magnetism. A short or open in the stator coil will result in either a low output, or no output at all. A loss in rotor magnetism, which may be caused by dropping or hitting the rotor, leaving it near an electromagnetic field, or just by aging, will result in low output.

Alternator output test

Before starting alternator output test, warm up the engine to obtain actual alternator operating condition.

- Remove the engine sprocket cover (Pg. 54), and disconnect the yellow leads from the stator. Set the multimeter to the 250V AC scale, and connect the meter leads to the yellow leads.

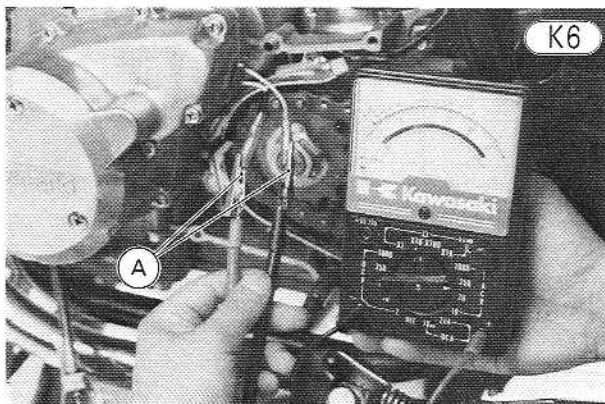

A. Yellow Leads

- Start the engine, run it at the rpm given in Table K3, and note the voltage reading. A much lower reading than that given in the table indicates that the alternator is defective.

Table K3 Alternator Output

| Meter | Reading @4,000 rpm |
|---------|--------------------|
| 250V AC | about 75V |

Stator coil resistance check

- Disconnect the meter leads from the stator leads.
- Set the multimeter to the $\times 1 \Omega$ range, and measure for continuity between the yellow leads. If there is more resistance than shown in Table K4, or no meter reading, the stator coil has an open and must be replaced.

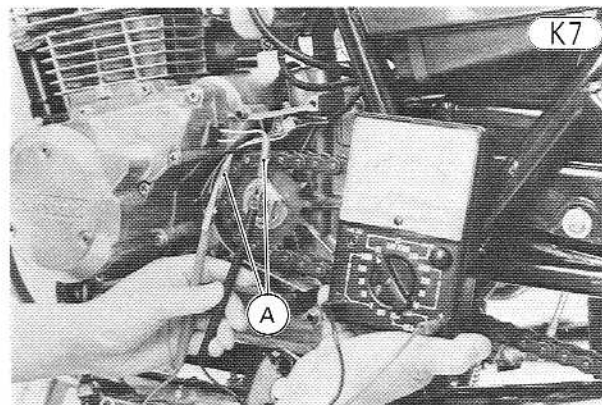

A. Yellow Leads

Table K4 Stator Coil Resistance

| Meter | Reading |
|-------------------|----------------------|
| $\times 1 \Omega$ | 0.36 ~ 0.54 Ω |

- Using the highest resistance range of the multimeter, measure the resistance between each of the yellow leads and chassis ground. Any meter reading less than infinity (∞) indicates a short, necessitating stator replacement.

If the stator windings have normal resistance, but the voltage check showed the alternator to be defective, then the magnets have probably weakened, and the rotor must be replaced.

Regulator/Rectifier

Before testing the regulator/rectifier out of circuit, check the charging voltage and alternator output voltage.

The regulator/rectifier used on this motorcycle is a solid-state type. Each function can be checked separately, but the regulator/rectifier must be replaced as a unit if either function is faulty.

CAUTION When inspecting the regulator/rectifier, observe the following to avoid damage to the regulator/rectifier.

1. Do not disconnect the regulator/rectifier with the ignition switch on. This may damage the regulator/rectifier.
2. Do not disconnect the battery leads while the engine is running. This may damage the regulator/rectifier.

Rectifier inspection

- With the ignition switch turned off, remove the right side cover, and disconnect the white/red regulator/rectifier lead and white connector.

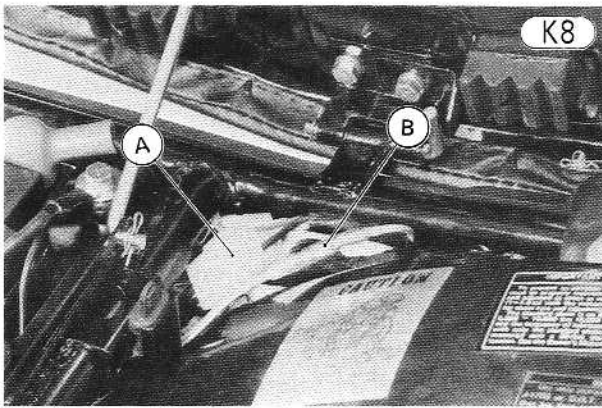

A. Connector B. White/Red Lead

- Using the $\times 10 \Omega$ or $\times 100 \Omega$ ohmmeter range, check the resistance in both directions between the black lead and each yellow lead; total of 4 measurements. The resistance should be low in one direction and more than ten times as much in the other direction. If any two leads are low or high in both directions, the rectifier is defective and the regulator/rectifier must be replaced.

Rectifier Check

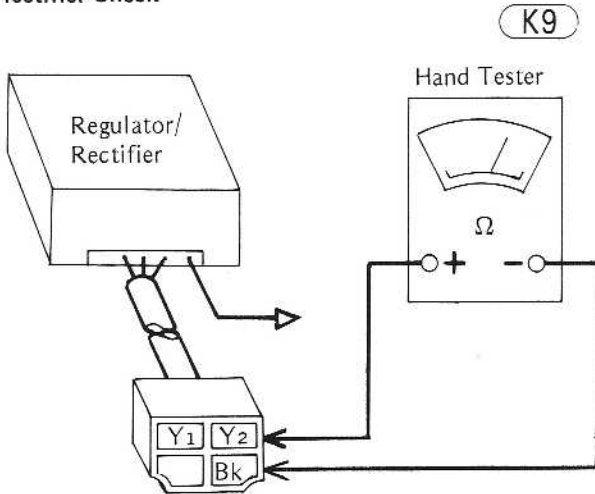

Table K5 Rectifier Check

| | Hand Tester Leads Connection | |
|---|----------------------------------|----------------------------------|
| | $\frac{1}{3}$ Scale | ∞ |
| 1 | (+) $Y_1 \leftrightarrow$ Bk (-) | (-) $Y_1 \leftrightarrow$ Bk (+) |
| 2 | (+) $Y_2 \leftrightarrow$ Bk (-) | (-) $Y_2 \leftrightarrow$ Bk (+) |

NOTE: The actual meter reading varies with the meter used and the individual rectifier, but, generally speaking, the lower reading should be within 1/3 scale of zero ohms.

Regulator test

If the rectifier is good, next test the regulator out of circuit.

- Prepare a 12 V battery and a test light made from a 12 V 3~6 W bulb in a socket with leads.
- Remove the regulator/rectifier from the frame.
- Connect first the test light leads between the white/red lead and the black lead.

CAUTION The test light works as an indicator and also as a current limiter to protect the regulator/rectifier from excessive current. Do not use an ammeter instead of a test light.

- To apply 12 V to the regulator/rectifier, connect both yellow leads to the battery terminals. At this time, the bulb should light.
- The bulb should light even if the battery polarity is changed.
- If the bulb does not light in either or both directions, the regulator circuit is defective and the regulator/rectifier must be replaced.

Regulator Check

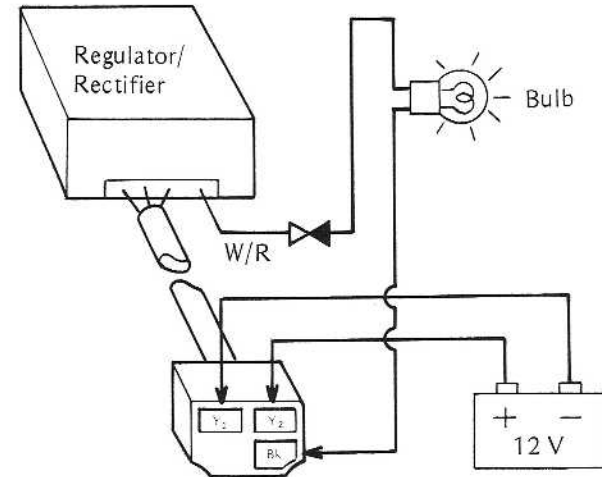

IGNITION SYSTEM

Ignition Circuit

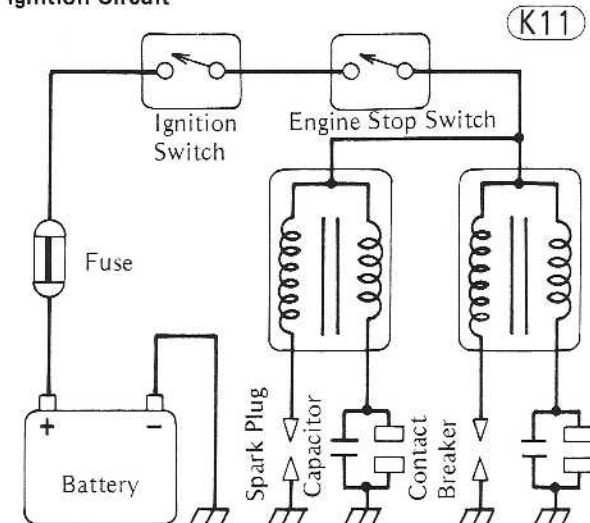

Ignition Coil

Ignition coil inspection

The most accurate test for determining the condition of the ignition coil is made with the Kawasaki Electrotester. The ignition coil must be connected to the tester in accordance with the tester directions and should produce at least a 5 mm spark. Since a tester other than the Kawasaki Electrotester may produce a different arcing distance, the Kawasaki Electrotester is recommended for reliable results.

Ignition Coil Test

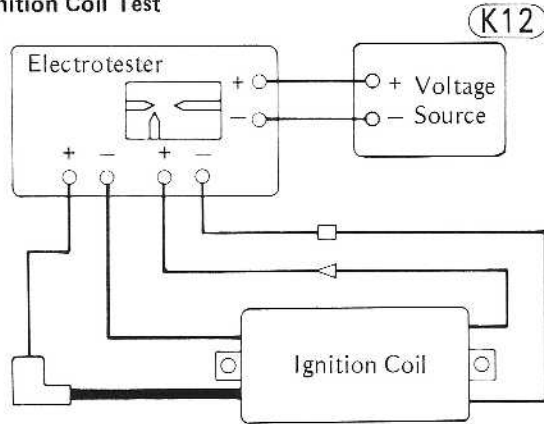

If an Electrotester is not available, the coil can be checked for a broken or badly shorted winding with an ohmmeter. However, an ohmmeter cannot detect layer shorts and shorts resulting from insulation breakdown under high voltage.

To measure the primary winding resistance:

- Remove the fuel tank (Pg. 39).
- Disconnect the ignition coil leads.
- Set the ohmmeter to the x 1 Ω range, and connect the ohmmeter leads to the leads from one of the ignition coils.

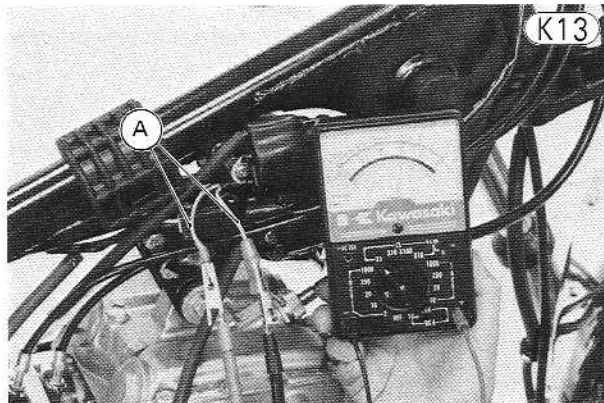

A. Ignition Coil Leads

To measure the secondary winding resistance:

- Disconnect the spark plug caps from the spark plugs, and pull the spark plug leads off the caps.
- Set the ohmmeter to the x 1 kΩ range, and connect one ohmmeter lead to the spark plug lead and the other ohmmeter lead to the yellow/red lead from the ignition coil.

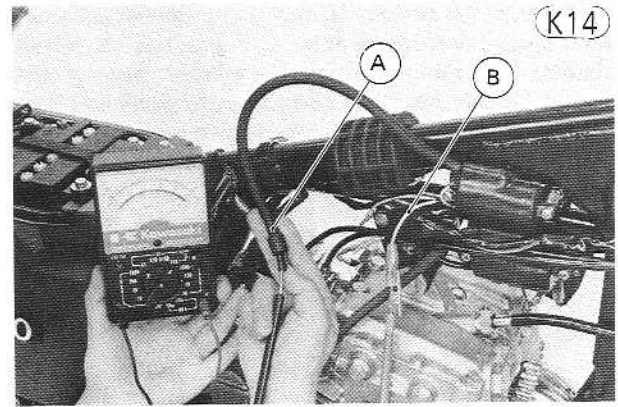

A. Spark Plug Leads

B. Yellow/Red Lead

Table K6 Ignition Coil Resistance

| | Meter | Reading |
|-------------------|--------|-----------|
| Primary Winding | x 1 Ω | 3.6~5.4 Ω |
| Secondary Winding | x 1 kΩ | 11~17 kΩ |

If the coil does not produce an adequate spark, or if either the primary or secondary winding does not have the correct resistance, replace the ignition coil.

With the highest ohmmeter range, check for continuity between the yellow/red lead and the coil core and between each plug lead and the coil core. If there is any reading, the coil is shorted and must be replaced. Also, replace the ignition coil if the spark plug lead shows visible damage.

Contact Breaker

Contact breaker inspection

When the points become dirty, pitted, or burned, or if the spring weakens, the points will not make the contact necessary to produce a good spark, resulting in unstable idling, misfiring, or the engine not running at all. Inspect the contact breaker in accordance with the Periodic Maintenance Chart (Pg. 10), and repair or replace if necessary.

Clean the points with clean paper or cloth using an oil-free solvent. A business card soaked in trichloroethylene can be used to remove traces of oil. To repair light damage, use fine emery cloth or an oilstone. If the points are badly worn down or damaged, or if the spring is weak, replace the contact breaker.

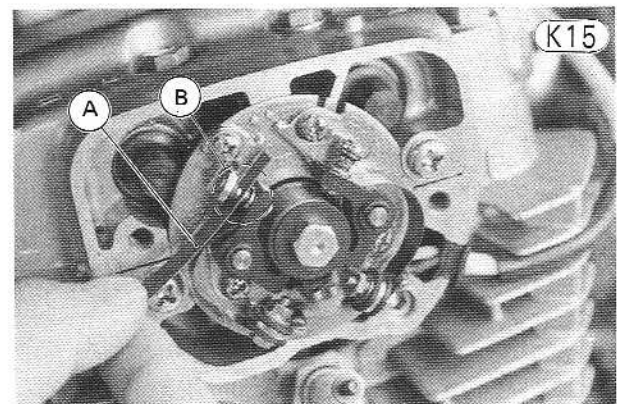

A. Fine Emery Cloth

B. Points

162 MAINTENANCE—ELECTRICAL

Whenever the contact breaker is inspected or replaced, apply a small amount of point cam grease to the felt to lubricate the cam. This will minimize wear of the contact breaker heel. Be careful not to apply so much grease that it can drop off or be thrown onto the points, which will cause the points to foul and burn.

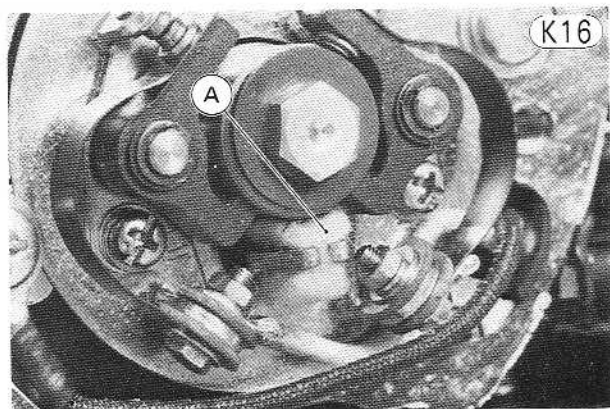

A. Felt

Capacitor

Capacitor inspection

The capacitor can usually be considered to be defective if a long spark is seen arcing across the points as they open or if the points are burned or pitted for no apparent reason. Replace the capacitor any time it appears defective and whenever the contact breaker is replaced.

NOTE: For checking with a capacitor tester, capacitor specifications are $0.24 \pm 0.02 \mu\text{fd}$, 1,000W VDC.

Capacitor Test

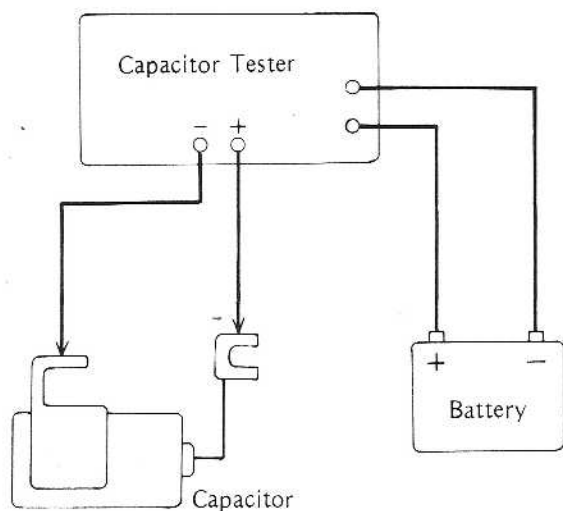

K17

Timing Advancer

Ignition Timing/Engine Speed Relationship

K18

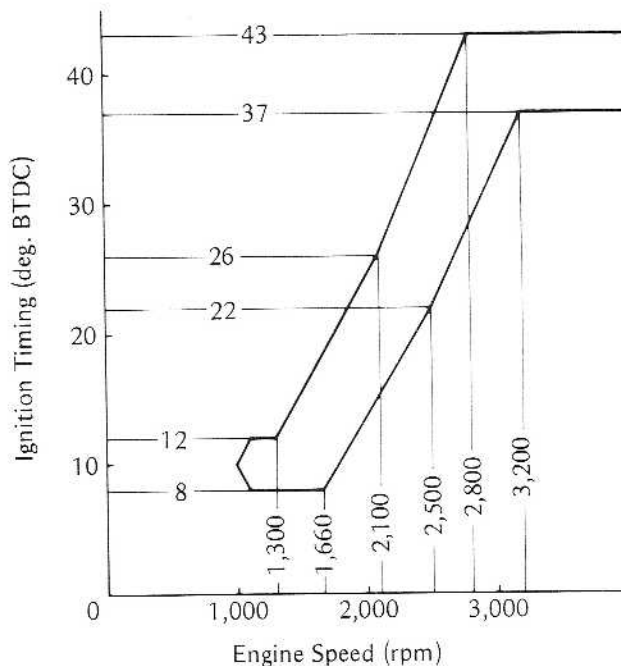

Inspection and lubrication

Remove the timing advancer (Pg. 61), and check that the mechanism moves smoothly by hand and that no parts are visually worn or damaged. Periodically wipe the advancer clean, apply oil to it, and fill the groove inside the cam with good quality, high temperature grease. See page 62 for recommended grease.

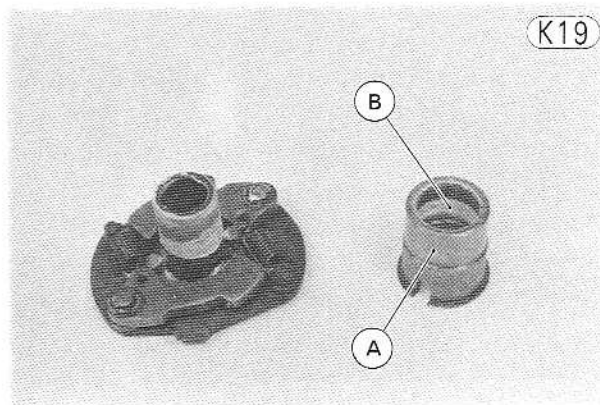

A. Cam Body

B. Grease

Install the advancer (Pg. 61), adjust the timing (Pgs. 12 ~ 15), and check it with a strobe light for both low and high speed operation. If the timing differs from that which is shown in the graph (Fig. K18), replace the timing advancer with a new one.

K19

Spark Plugs

Spark Plug

K20

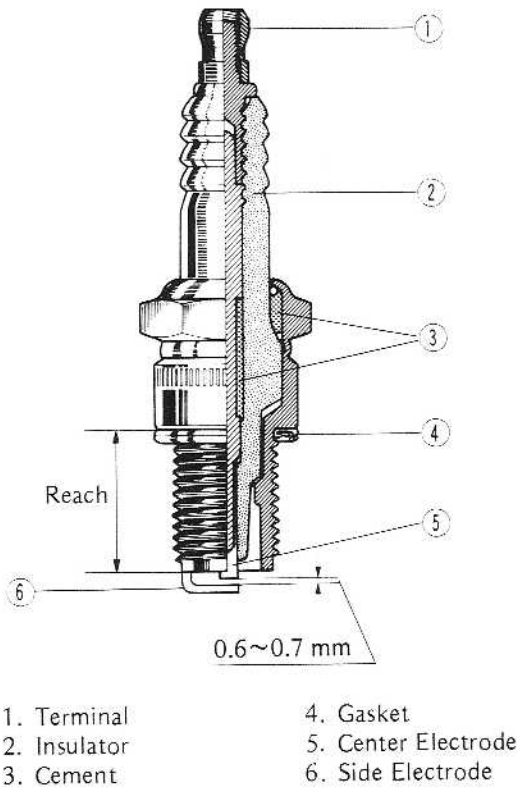

Inspection and replacement

Remove each plug and inspect the ceramic insulator. Whether or not the right temperature plug is being used can be ascertained by noting the condition of the ceramic insulator around the electrode. A light brown color indicates the correct plug is being used. If the ceramic is white, the plug is operating at too high a temperature and it should be replaced with the next colder type.

The heat range of the spark plug functions like a thermostat for the engine. Using the wrong type of spark plug can make the engine run too hot (resulting

in engine damage) or too cold (with poor performance, misfiring, and stalling). The standard plug has been selected to match the normal usage of this motorcycle in combined street and highway riding. Unusual riding conditions may require a different spark plug heat range.

CAUTION If the spark plugs are replaced with a type other than those mentioned below, make certain the replacement plugs have the same thread pitch and reach (length of threaded portion) as the standard plugs.

Table K7 Spark Plug Specifications

| Required Plug Threads | Plug Type |
|-----------------------|----------------------------|
| 12 mm Diameter | NGK D8EA or ND X24ES-U |
| 19.0 mm Reach | Ⓔ NGK DR8ES or ND X24ESR-U |

Ⓔ : European model except Italian model

Spark Plug Reach

K21

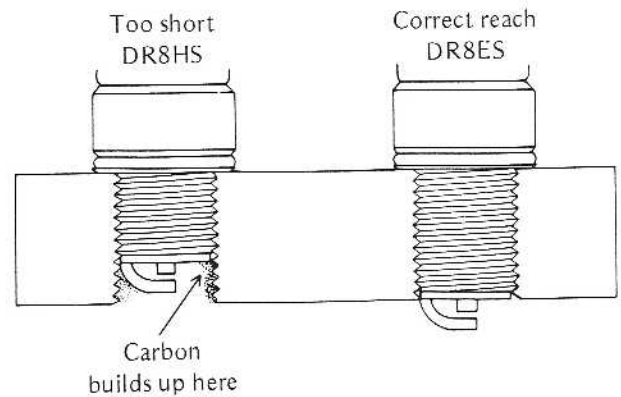

If the plug reach is too short, carbon will build up on the plug hole threads in the cylinder head, causing overheating and making it very difficult to insert the correct spark plug later.

If the reach is too long, carbon will build up on the exposed spark plug threads causing overheating, preignition, and possibly burning a hole in the piston top. In addition, it may be impossible to remove the plug without damaging the cylinder head.

Spark Plug Condition

K22

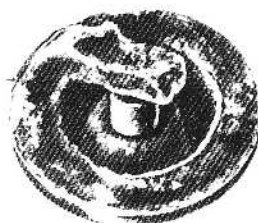

Carbon Fouling



Oil Fouling

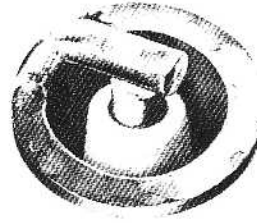

Normal Operation



Overheating

ELECTRIC STARTER SYSTEM

Starter Motor Circuit

CAUTION Because of the large amount of current, never keep the starter button pushed any time that the starter motor will not turn over, or the current may burn out the starter motor windings.

Starter Motor Circuit

(K23)

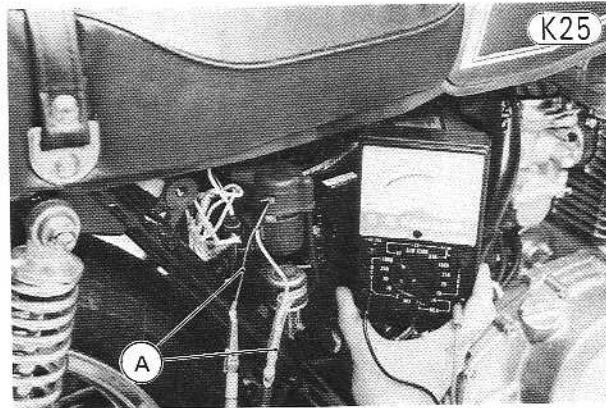
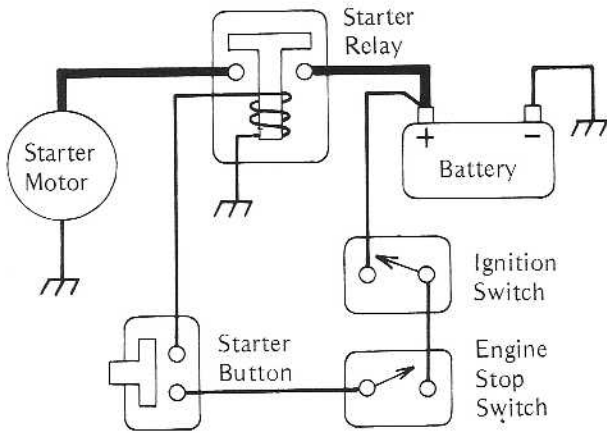

A. Relay Leads

However, if there is not 4 ohms resistance, the relay may be good; check that there is actual voltage to the relay before deciding that the relay is defective.

- To check for the voltage, first turn the meter to 20V DC, connect the - meter lead to the yellow/red lead which was disconnected from the relay, and connect the + meter lead to the black lead. Push the starter button, and see if the meter reads battery voltage. If it does not, there is wiring trouble. If the meter reads battery voltage but the relay does not click, the relay is defective.

Starter relay test

- Disconnect the starter motor lead from the starter relay, and connect an ohmmeter set to the x 1 Ω range across the relay terminals.
- Turn on the ignition switch, push the starter button, and see if the meter reads zero ohms. If the relay makes a single clicking sound and the meter reads zero, the relay is good. If the relay clicks but the meter does not read zero, the relay is defective, and must be replaced.

Starter Motor

Carbon brushes

Worn brushes or weak springs will cause poor brush contact. Make sure that the spring tension is strong enough to push the brush out.

Measure the length of the brushes, and replace both if either one is worn down to less than the service limit.

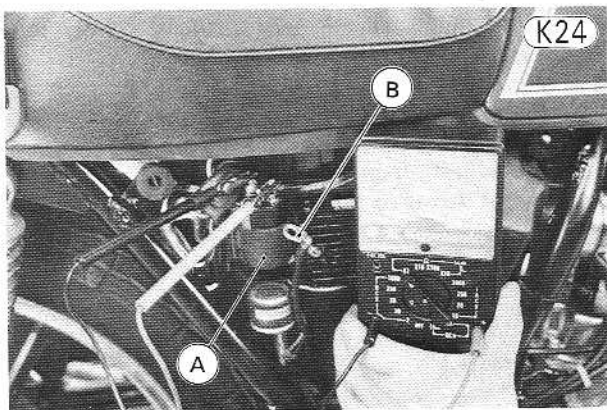

A. Starter Relay B. Remove the starter motor lead

- If the relay does not click at all, disconnect the other two leads (black and yellow/red) in the right side cover, and measure the resistance across them. If the resistance is not about 4 ohms, the relay is defective.

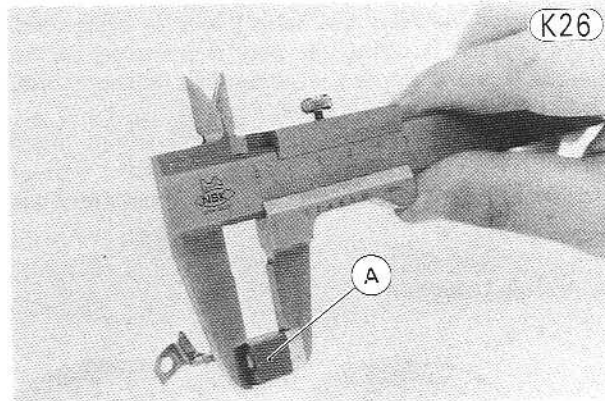

A. Carbon Brush

Table K8 Carbon Brush Length

| Standard | Service Limit |
|--------------|---------------|
| 11.0~12.5 mm | 6 mm |

Starter Motor Construction

(K27)

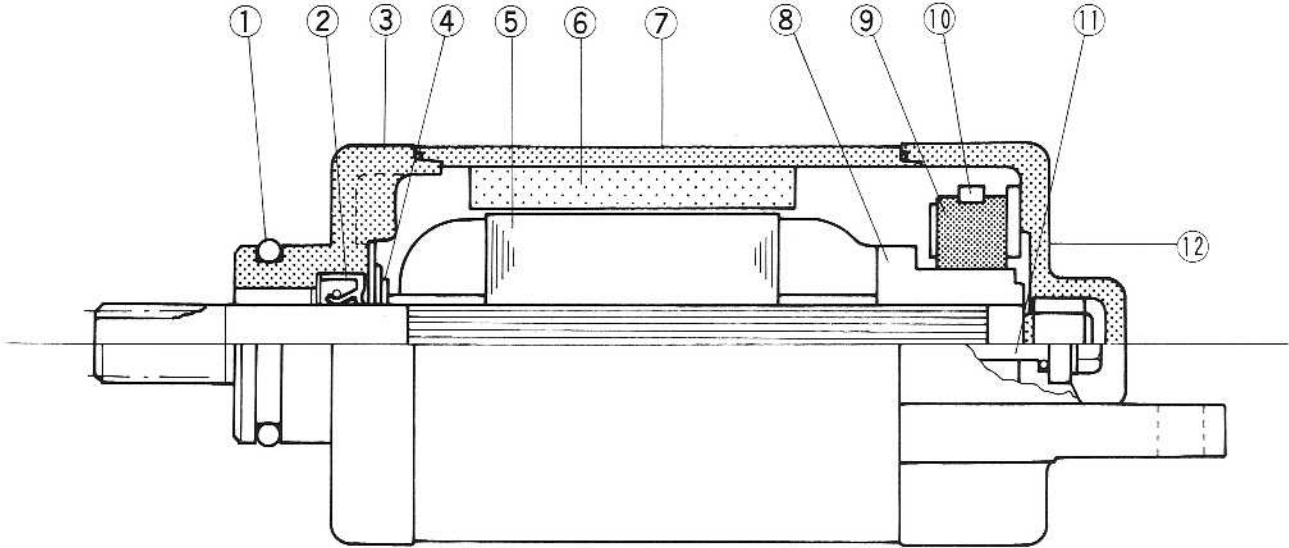

- 1. O Ring
- 2. Grease Seal
- 3. End Cover
- 4. Shims
- 5. Armature
- 6. Magnet
- 7. Body
- 8. Commutator
- 9. Carbon Brush
- 10. Spring
- 11. Screw
- 12. End Cover

Commutator

A dirty or damaged commutator will result in poor brush contact and cause the brushes to wear down quickly. In addition, particles from brush wear accumulating between commutator segments may cause partial shorts.

•Correct the commutator surface if necessary with fine emery cloth, and clean out the grooves as illustrated. Determine as accurately as possible the depth of the grooves between commutator segments. Replace the starter motor with a new one if the groove depth is less than the service limit.

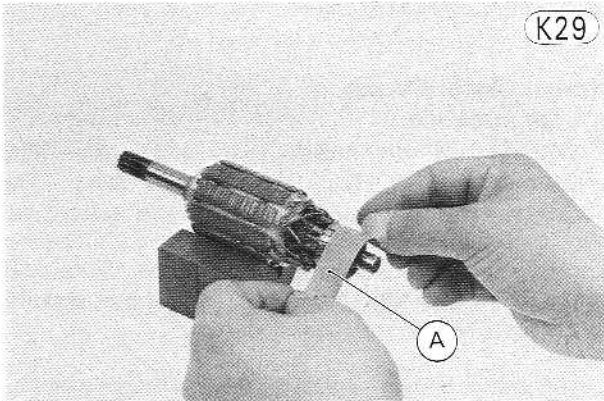

A. Emery Cloth

•Using the x 1 Ω ohmmeter range, measure the resistance between any two commutator segments. If there is a high resistance or no reading between any two segments, a winding is open and the armature must be replaced.

Commutator

(K28)

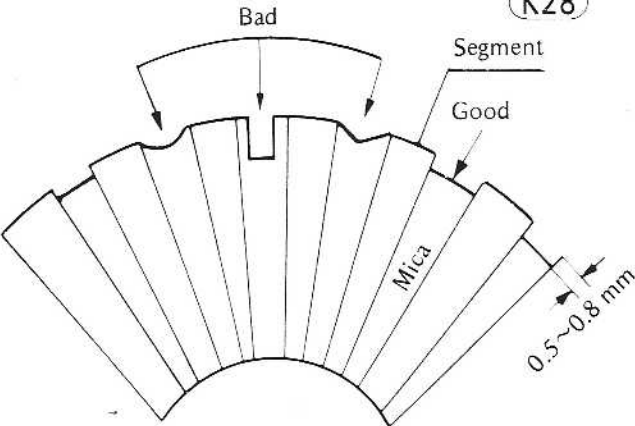
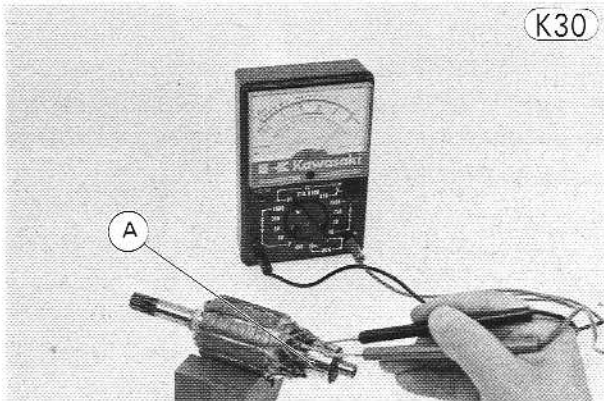

Table K9 Commutator Groove Depth

| Standard | Service Limit |
|------------|---------------|
| 0.5~0.8 mm | 0.2 mm |



A. Commutator Segment

- Using the highest ohmmeter range, measure the resistance between the commutator and the shaft. If there is any reading at all, the armature has a short and must be replaced.

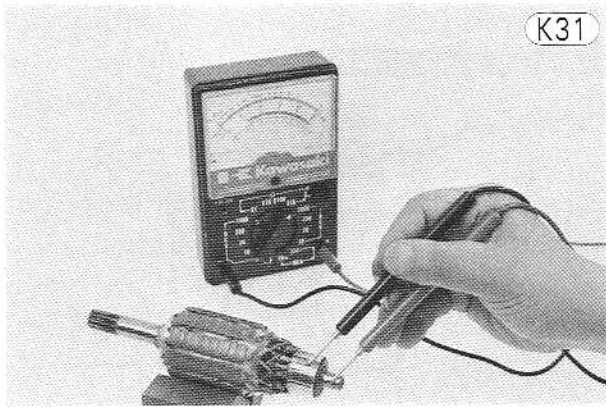

NOTE: Even if the foregoing checks show the armature to be good, it may be defective in some manner not readily detectable with an ohmmeter. If all other starter motor and starter motor circuit components check good, but the starter motor still does not turn over or only turns over weakly, replace the starter motor with a new one.

Starter Motor Clutch

Clutch inspection

Remove the left engine cover and starter idler gear, and turn the starter drive gear by hand. The starter drive gear should turn clockwise freely, but should not turn counterclockwise. If the clutch does not operate as it should or if it makes noise, disassemble the starter clutch (Pg. 56), examine each part visually, and replace any worn or damaged parts.

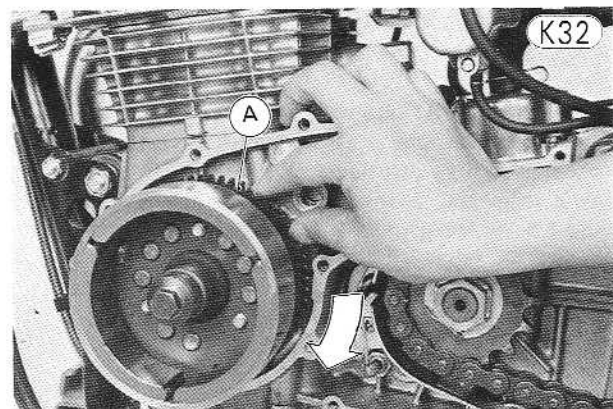

A. Starter Drive Gear

IGNITION SWITCH

Testing the switch

Table K9 shows the internal connections of the ignition switch for each switch position. To check the

switch, remove the headlight unit, and disconnect the plug (4-pin) from the ignition switch in the headlight housing. Use an ohmmeter to verify that all the connections listed in the table are making contact (zero ohms between those wires); and that no other wires are connected. If there are any opens or shorts in the switch, replace it with a new one.

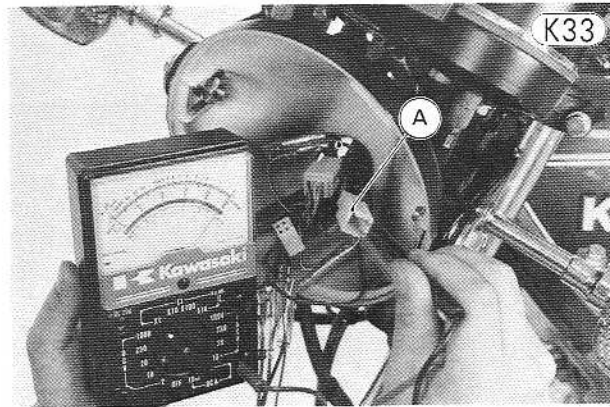

A. Ignition Switch 4-pin Plug

Table K10 Ignition Switch Connections

| Color | White | Brown | Red/Blue | Red |
|-------|--------|-------|-----------------|-----------------|
| ON | ●————● | | ●————● | |
| OFF | | | | |
| LOCK | | | | |
| PARK | ●————● | | | |
| Lead | BAT | IG | TL ₁ | TL ₂ |

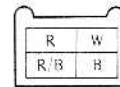

NEUTRAL INDICATOR SWITCH

Switch inspection

- Turn on the ignition switch. Watching the indicator light, shift the transmission into neutral and then shift the transmission into other positions. If the neutral indicator light goes on in neutral position and the light does not go on in other positions, the neutral indicator switch is good.
- If the neutral indicator light does not go on in the neutral position or if it does go on in other positions, remove the engine sprocket cover, (Pg. 54), and disconnect the neutral indicator switch light green lead.
- To check for the voltage, first turn the meter to 20V DC, connect the + meter lead to the switch lead, and connect the – meter lead to chassis ground.
- Turn the ignition switch on, and see if the meter reads battery voltage. If the meter does not indicate battery voltage, the trouble is either defective wiring or a burned-out indicator bulb. If the voltmeter reads battery voltage, then the neutral indicator switch may be defective.

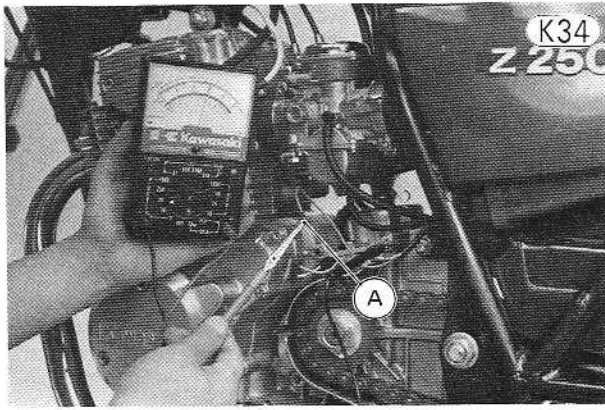

A. Switch Lead

- To check the neutral switch, first remove the switch, turn the meter to the $\times 1 \Omega$ range, and measure the resistance between the switch terminal and the spring loaded pin. If the resistance is not close to zero ohms, the switch is defective, and must be replaced.

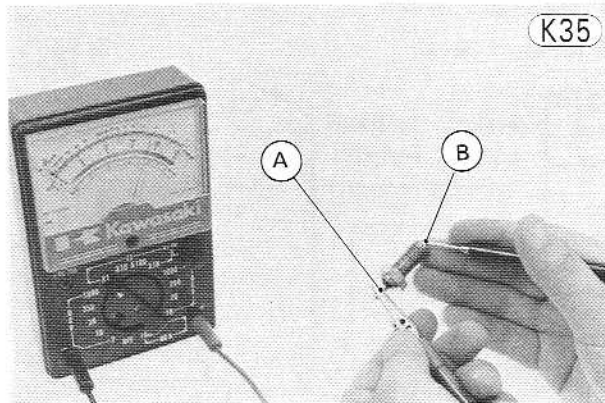

A. Switch Terminal

B. Spring Loaded Pin

- If the resistance is close to zero ohms, measure the resistance between the switch terminal or spring loaded pin and the switch body. If there is any meter reading, the neutral indicator switch is defective and must be replaced.
- If all these checks turned out good, the trouble will be due to poor contact of the neutral switch with the screw on the shift drum (Fig. F37).

LIGHTING SYSTEM Headlight Circuit

If the headlight does not light, check to see if the bulb has burned out or fuse has blown. A blown fuse should be replaced. The headlight or the city light can be replaced separately, as the headlight is of semi-sealed construction. If the bulb and fuse are good, check the dimmer switch and the headlight switch. Tables K10 and K12 show the connections in the dimmer switch for both high and low beam, and the connections in the headlight switch.

To check the dimmer switch and horn/passing switch:

- Remove the fuel tank (Pg. 39), and disconnect the plug (6-pin), blue lead, and black lead to the left switch housing under the frame top tube.
- Use an ohmmeter to see that only the connections shown in the table have continuity (zero ohms). If the switch has an open or a short, it can be disassembled for repair. The contact surfaces may be cleaned, but no internal parts are available for replacement. If any parts are not repairable, the switch must be replaced as a unit. If the procedure above does not remedy the problem, check the ignition switch and the wiring.

Headlight Circuit

K36

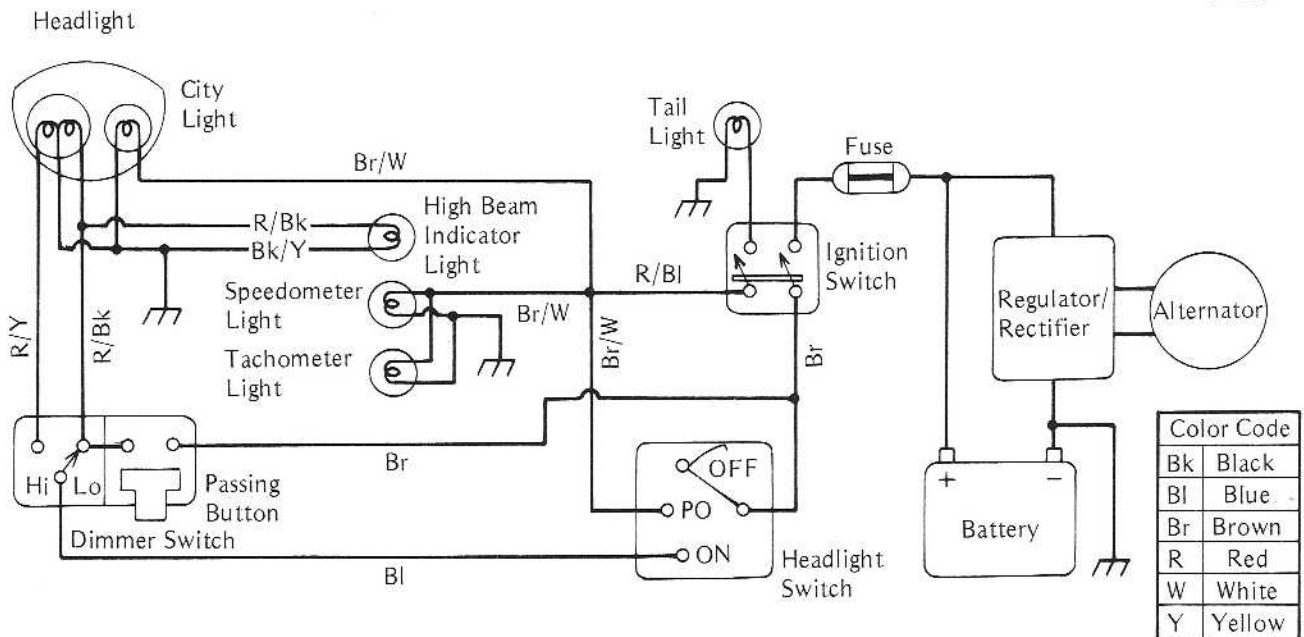

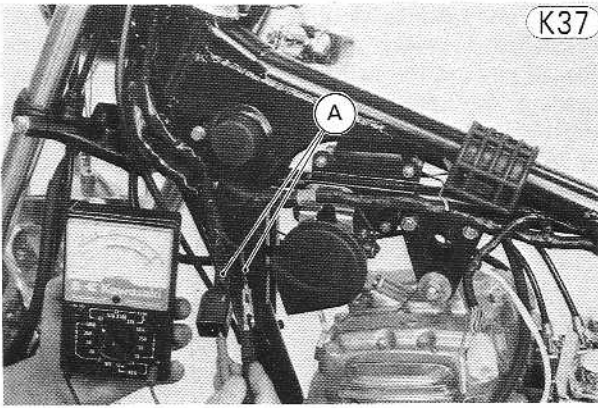

A. Left Switch Housing Plug and Lead

Table K11 Dimmer Switch Connections

| Color | Red/Black | Blue | Red/Yellow |
|-------|-----------|--------|------------|
| HI | ●————● | | |
| LO | | ●————● | |

Table K12 Horn/Passing Switch Connections

| Color | Black | /// | R/Bk | Brown |
|--------|--------|-----|---------|-------|
| OFF | | | | |
| ON | ●————● | | ●————● | |
| Switch | Horn | | Passing | |

| | |
|-----|-----|
| R/B | Br |
| Cy | R/Y |
| O | G |

To check the headlight switch

- Remove the fuel tank (Pg. 39), and disconnect the plug (4-pin) and blue/white lead to the right switch housing under the frame top tube.
- Use an ohmmeter to see that only the connections shown in the table have continuity (zero ohms). If the switch has an open or a short, it can be disassembled for repair. The contact surfaces may be cleaned, but no internal parts are available for replacement. If any parts are not repairable, the switch must be replaced as a unit. If the procedure above does not remedy the problem, check the ignition switch and the wiring.

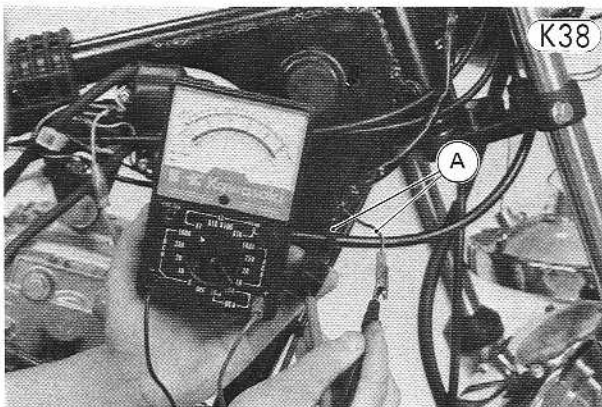

A. Right Switch Housing Plug and Lead

Table K13 Headlight Switch Connections

| Color | Brown | Brown/White | Blue/White |
|-------|-------------|-------------|------------|
| OFF | | | |
| PO | ●————● | | |
| ON | ●————●————● | | |

| | |
|-----|------|
| Br | Br/W |
| Y/R | Bk |

If the headlight lights but does not light brightly, the trouble may be that the headlight is of improper wattage or the battery or the alternator is not supplying sufficient current. However, the trouble may also be caused by a short or a component drawing too much current in some other part of the electrical system.

Tail light trouble

If the tail light does not go on when the circuit is closed, the filament is probably burned out. However, if the bulb is good, check the fuse, wiring, ignition switch, headlight switch, and battery.

Brake Light Circuit

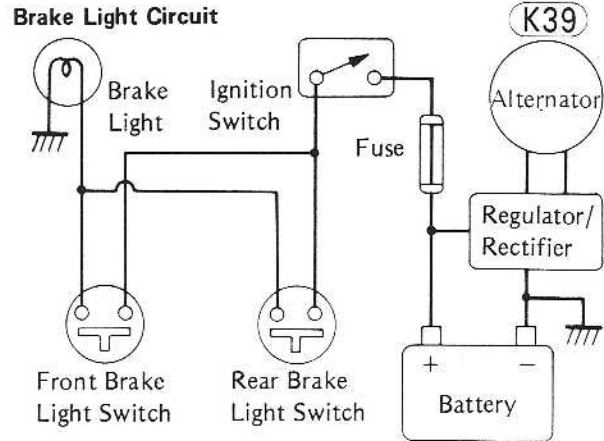

Front brake light switch inspection

- Remove the headlight unit.
- Disconnect the front brake light switch leads (brown, blue).
- Set an ohmmeter to the $\times 1 \Omega$ range, connect the meter to the switch leads, and determine whether or not there is continuity whenever the front brake lever is squeezed.

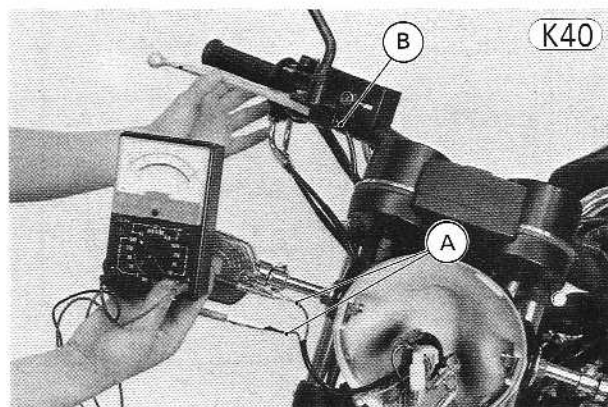

A. Brake Light Switch Leads

- If there is no continuity, replace the switch with a new one.

Rear brake light switch inspection

- Disconnect the rear brake light switch leads (brown, blue) under the fuel tank.
- Inspect in the same way that the front brake light switch was inspected. If there is no continuity whenever the rear brake pedal is depressed, replace the switch.

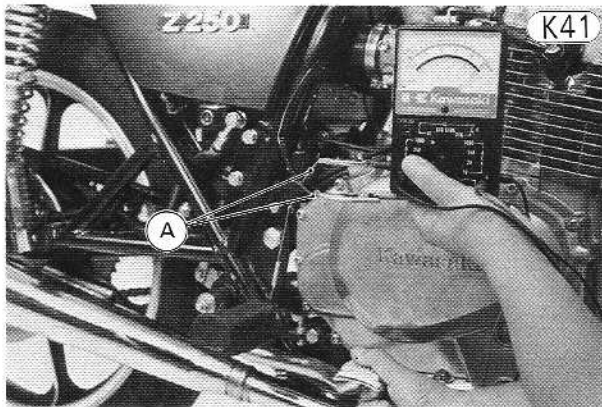

A. Brake Light Switch Leads

Turn Signal Circuit

Turn Signal Circuit

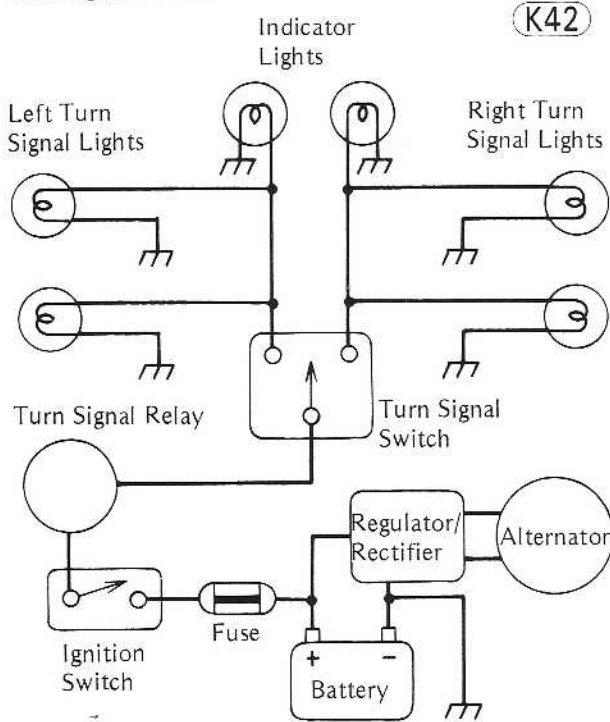

Turn signal trouble

- (1) Neither right nor left turn signals come on at all:
 - Check that battery voltage is normal.
 - Disconnect the relay leads and use an ohmmeter to check that there is continuity (close to zero

ohms) between the relay terminals. If there is no ohmmeter reading, or if there is several ohms resistance, replace the relay with a new one.

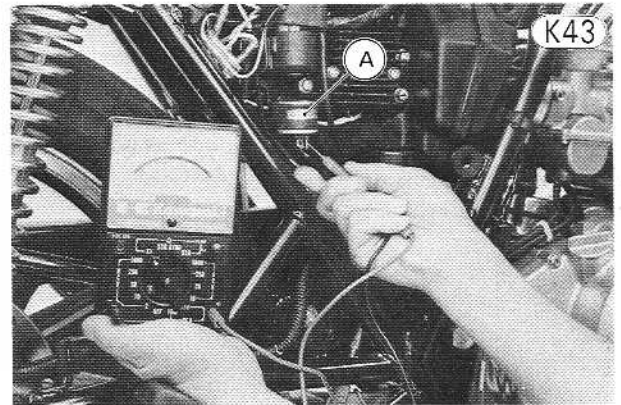

A. Turn Signal Relay

- If the relay checks good, turn the meter to 20V DC range, connect the + meter lead to the brown lead that was disconnected from the relay, and connect the - meter lead to the orange lead.
- With the ignition switch on, first switch the turn signal switch to the "R" and then to the "L" position. The meter should register battery voltage at either position. If it does not, the fuse, ignition switch, or wiring is at fault. If battery voltage is read on the meter but the turn signals still will not work when the relay is reconnected, then recheck all wiring connections.

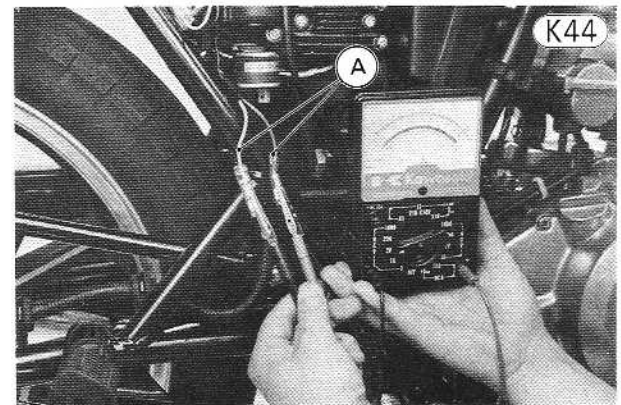

A. Relay Leads

- (2) Both right or both left turn signals come on and stay on or flash too slowly:
 - Check that battery voltage is not low.
 - Check that all wiring connections are good.
 - Check that the turn signal bulbs and indicator bulb are of the correct wattage.
 - If all of the above check good, replace the relay.
- (3) A single light on one side comes on and stays on:
 - Either the light that does not come on is burned out, of the incorrect wattage, or the wiring is broken or improperly connected.

170 MAINTENANCE—ELECTRICAL

- (4) Neither light on one side comes on:
- Unless both lights for that side are burned out, the trouble is with the turn signal switch.
- (5) Flashing rate is too fast:
- If this occurs on both the right and left sides, check that the battery is not being overcharged (indicating a defective regulator/rectifier). If the alternator and the battery voltage are normal, replace the turn signal relay.
 - If this occurs on only one side, one or both of the turn signal bulbs are of too high a wattage.

HORN

Horn trouble

- Check that battery voltage is normal.
- Disconnect the leads to the horn, and connect a multimeter set to the $\times 1 \Omega$ range to the horn terminals to check for continuity (close to zero ohms). If the reading is several ohms or if there is no reading at all, replace the horn.
- If the reading is very close to zero, set the multimeter to the 20V DC range, and connect the meter to the leads that were disconnected from the horn. The + meter lead goes to the brown lead, and the -- meter lead goes to the black lead.
- With the ignition switch on, press the horn button. The meter should register battery voltage. If it does not, the fuse, ignition switch, or wiring is at fault.

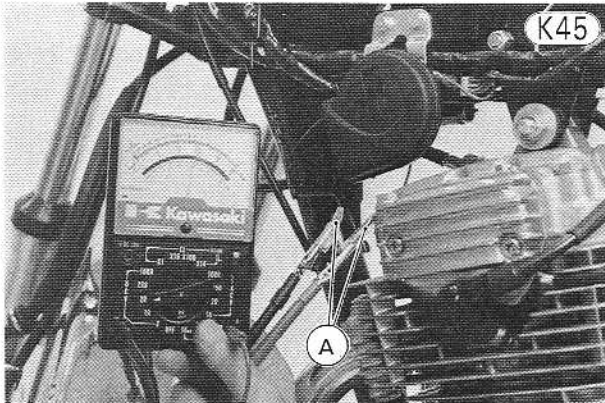

A. Horn Leads

- If the meter does show battery voltage, indicating that the horn trouble lies within the horn itself, and adjustment fails to correct the trouble, replace the horn.
- NOTE:** Do not loosen the armature mounting since doing so would alter the armature position such that the horn would probably have to be replaced.

Troubleshooting—Guide

Engine Doesn't Start; Starting Difficulty

Starter motor not rotating

- Starter motor trouble
- Battery voltage low
- Relay not contacting or operating
- Starter button not contacting
- Wiring open or shorted
- Ignition switch trouble
- Engine stop switch off
- Engine stop switch trouble
- Fuse blown

Starter motor rotating but engine doesn't start

- Starter motor clutch trouble
- Starter idler gear slipping on the shaft

Engine won't turn over

- Valve seizure
- Cylinder, piston seizure
- Crankshaft seizure
- Connecting rod small end seizure
- Connecting rod big end seizure
- Transmission gear or bearing seizure
- Camshaft seizure

No fuel flow

- No fuel in tank
- Fuel tap turned off
- Tank cap air vent obstructed
- Fuel tap clogged
- Fuel line clogged
- Float valve clogged

Engine flooded

- Fuel level too high
- Float valve worn or stuck open
- Starting technique faulty
(When flooded, press the starter button with the throttle fully open to allow more air to reach the engine.)

No spark; spark weak

- Battery voltage low
- Spark plug dirty, damaged, or maladjusted
- Spark plug cap or spark plug lead trouble
- Spark plug cap shorted or not in good contact
- Contact breaker points dirty or damaged
- Contact breaker point gap maladjusted
- Capacitor damaged
- Ignition coil damaged
- Ignition or engine stop switch shorted
- Wiring shorted or open

Compression low

- Spark plug loose
- Cylinder head not sufficiently tightened down
- No valve clearance
- Cylinder, piston worn
- Piston rings bad (worn, weak, broken, or sticking)
- Piston ring/land clearance excessive
- Cylinder head gasket damaged
- Cylinder head warped
- Valve sticking
- Valve not closing
- Valve spring broken or weak

- Valve not seating properly (valve bent, warped, or worn)

Poor Running at Low Speed

Spark weak

- Battery voltage low
- Spark plug dirty, damaged, or maladjusted
- Spark plug cap or spark plug lead trouble
- Spark plug cap shorted or not in good contact
- Spark plug incorrect
- Contact breaker points dirty or damaged
- Contact breaker point gap maladjusted
- Capacitor damaged
- Ignition coil damaged

Fuel/air mixture incorrect

- Pilot screw(s) maladjusted
- Pilot jet, or air passage clogged
- Air cleaner clogged, poorly sealed, or missing
- Air cleaner duct poorly seated
- Fuel level too high or too low
- Fuel tank air vent obstructed
- Carburetor holders loose

Compression low

- Spark plug loose
- Cylinder head not sufficiently tightened down
- No valve clearance
- Cylinder, piston worn
- Piston rings bad (worn, weak, broken or sticking)
- Piston ring/land clearance excessive
- Cylinder head gasket damaged
- Cylinder head warped
- Valve sticking
- Valve not closing
- Valve spring broken or weak
- Valve not seating properly (valve bent, warped, or worn)

Other

- Ignition timing maladjusted
- Timing not advancing (spring broken or stretched)
- Carburetors not synchronizing
- Engine oil viscosity too high
- Brakes dragging

Poor Running or No Power at High Speed

Firing incorrect

- Battery voltage low
- Spark plug dirty, damaged, or maladjusted
- Spark plug cap or spark plug lead trouble
- Spark plug cap shorted or not in good contact
- Spark plug incorrect
- Contact breaker points dirty or damaged
- Contact breaker point gap maladjusted
- Capacitor damaged
- Ignition coil damaged
- Ignition timing maladjusted and/or timing not advancing
- Contact breaker spring weak

172 TROUBLESHOOTING GUIDE

Fuel/air mixture incorrect

- Main jet clogged or wrong size
- Jet needle or needle jet worn
- Jet needle clip in wrong position
- Fuel level too high or too low
- Needle jet bleed hole clogged
- Air cleaner clogged, poorly sealed, or missing
- Water or foreign matter in fuel
- Carburetor holders loose
- Fuel tank air vent obstructed
- Fuel tap clogged
- Fuel line clogged

Compression low

- Spark plug loose
- Cylinder head not sufficiently tightened down
- No valve clearance
- Cylinder, piston worn
- Piston rings bad (worn, weak, broken, or sticking)
- Piston ring/land clearance excessive
- Cylinder head gasket damaged
- Cylinder head warped
- Valve sticking
- Valve not closing
- Valve spring broken or weak
- Valve not seating properly (valve bent, warped, or worn)

Knocking

- Ignition timing maladjusted
- Carbon built up in combustion chamber
- Fuel poor quality or incorrect
- Overheating
- Spark plug incorrect

Other

- Throttle valve won't fully open
- Vacuum pistons don't slide smoothly
- Damaged diaphragm
- Ignition timing maladjusted
- Timing not advancing
- Brakes dragging
- Clutch slipping
- Overheating
- Engine oil level too high
- Engine oil viscosity too high

Overheating

Firing incorrect

- Spark plug dirty, damaged, or maladjusted
- Ignition timing maladjusted
- Spark plug incorrect

Fuel/air mixture incorrect

- Main jet clogged
- Fuel level too low
- Carburetor holders loose
- Air cleaner clogged, poorly sealed, or missing

Compression high

- Carbon built up in combustion chamber

Engine load faulty

- Clutch slipping
- Engine oil level too high
- Engine oil viscosity too high
- Brakes dragging

Lubrication inadequate

- Engine oil level too low

- Engine oil poor quality or incorrect

Clutch Operation Faulty

Clutch slipping

- No clutch lever play
- Friction plate worn or warped
- Steel plates worn or warped
- Clutch springs weak
- Clutch release maladjusted
- Clutch inner cable catching
- Clutch release mechanism trouble
- Clutch hub or housing unevenly worn

Clutch not disengaging properly

- Clutch lever play excessive
- Clutch plates warped or too rough
- Clutch spring tension uneven
- Engine oil deteriorated
- Engine oil of too high a viscosity
- Engine oil level too high
- Clutch housing frozen on drive shaft
- Clutch release mechanism trouble
- Loose clutch hub nut

Gear Shifting Faulty

Doesn't go into gear; shift pedal doesn't return

- Clutch not disengaging
- Shift fork(s) bent or seized
- Gear(s) stuck on the shaft
- Shift return spring weak or broken
- External shift mechanism arm broken
- Shift return spring pin loose
- External shift mechanism arm spring broken

Jumps out of gear

- Shift fork(s) worn
- Gear groove(s) worn
- Gear dogs, dog holes, and/or dog recesses worn
- Shift drum groove(s) worn
- Shift fork pin(s) worn
- Drive shaft, output shaft, and/or gear splines worn

Overshifts

- Shift return spring pin loose
- External shift mechanism arm spring weak or broken

Abnormal Engine Noise

Knocking

- Ignition timing maladjusted
- Carbon built up in combustion chamber
- Fuel poor quality or incorrect
- Overheating
- Spark plug incorrect

Piston slap

- Cylinder/piston clearance excessive
- Cylinder, piston worn
- Connecting rod bent
- Piston pin, piston holes worn

Valve noise

- Valve clearance incorrect
- Valve spring broken or weak
- Rocker arms or rocker shaft worn

Other noise

Connecting rod small end clearance excessive
 Connecting rod big end clearance excessive
 Piston ring(s) worn, broken, or stuck
 Piston seizure damage
 Cylinder head gasket leaking
 Exhaust pipe leaking at cylinder head connection
 Crankshaft runout excessive
 Engine mounts loose
 Crankshaft bearings worn
 Camshaft chain tensioner trouble
 Camshaft chain, sprocket, guides worn
 Camshaft chain requires adjustment

Abnormal Drive Train Noise**Clutch noise**

Clutch housing/friction plate clearance excessive
 Weak or damaged shock damper

Transmission noise

Bearings worn
 Transmission gears worn or chipped
 Metal chips jammed in gear teeth
 Engine oil insufficient or too thin

Drive chain noise

Drive chain adjusted improperly
 Chain worn
 Rear and/or engine sprocket(s) worn
 Chain lubrication insufficient
 Rear wheel misaligned

Abnormal Frame Noise**Front fork noise**

Oil insufficient or too thin
 Spring weak or broken

Rear shock absorber noise

Shock absorber trouble

Disc brake noise

Pad B loose
 Pad surface glazed
 Disc warped
 Caliper seal damaged
 Cylinder damaged
 Wheel improperly installed

Other noise

Brackets, nuts, bolts, etc. not properly mounted or tightened

Exhaust Smokes Excessively**White smoke**

Piston oil ring worn
 Cylinder worn
 Valve oil seal damaged
 Valve guide worn
 O rings at the cylinder oil passage orifice are damaged
 Engine oil level too high

Black smoke

Air cleaner clogged
 Main jet too large or fallen off
 Fuel level too high

Brown smoke

Main jet too small
 Fuel level too low

Carburetor intake ducts loose
 Air cleaner poorly sealed or missing

Handling and/or Stability Unsatisfactory**Handlebar hard to turn**

Steering stem locknut too tight
 Bearing balls damaged
 Race(s) dented or worn
 Steering stem lubrication inadequate
 Steering stem bent
 Tire air pressure too low

Handlebar shakes or excessively vibrates

Tire(s) worn
 Swing arm bush and sleeve worn
 Rim(s) warped, or not balanced
 Wheel bearing(s) worn
 Handlebar clamps loose
 Steering stem head bolt and/or clamp bolt loose

Handlebar pulls to one side

Frame bent
 Wheel misalignment
 Swing arm bent or twisted
 Steering stem bent
 Front fork bent
 Right/left front fork oil level uneven
 Right/left rear shock absorbers unbalanced

Shock absorption unsatisfactory

Too hard:
 Front fork oil excessive
 Front fork oil viscosity too high
 Tire air pressure too high
 Shock absorber maladjusted
 Front fork bent
 Too soft:
 Front fork oil insufficient and/or leaking
 Front fork oil viscosity too low
 Front fork, rear shock absorber spring(s) weak
 Rear shock absorber oil leaking

Brakes Don't Hold**Disc Brake**

Air in the brake line
 Pad or disc worn
 Brake fluid leak
 Contaminated pads
 Brake fluid deteriorated
 Primary or secondary cup damaged
 Master cylinder scratched inside

Battery Discharged

Battery faulty (e.g., plates sulphated, shorted through sedimentation, electrolyte level too low)
 Battery leads making poor contact
 Load excessive (e.g., bulb of excessive wattage)
 Rectifier trouble
 Ignition switch trouble
 Regulator trouble
 Stator coil open or short
 Wiring faulty

174 TROUBLESHOOTING GUIDE

Battery Overcharged

Regulator trouble
Battery damaged

NOTE: This is not an exhaustive list, giving every possible cause for each problem listed. It is meant simply as a rough guide to assist the troubleshooting for some of the more common difficulties. Electrical troubleshooting is not covered here due to its complexity. For electrical problems, refer to the appropriate heading in the Maintenance Section.

SPECIAL TOOLS

Appendix

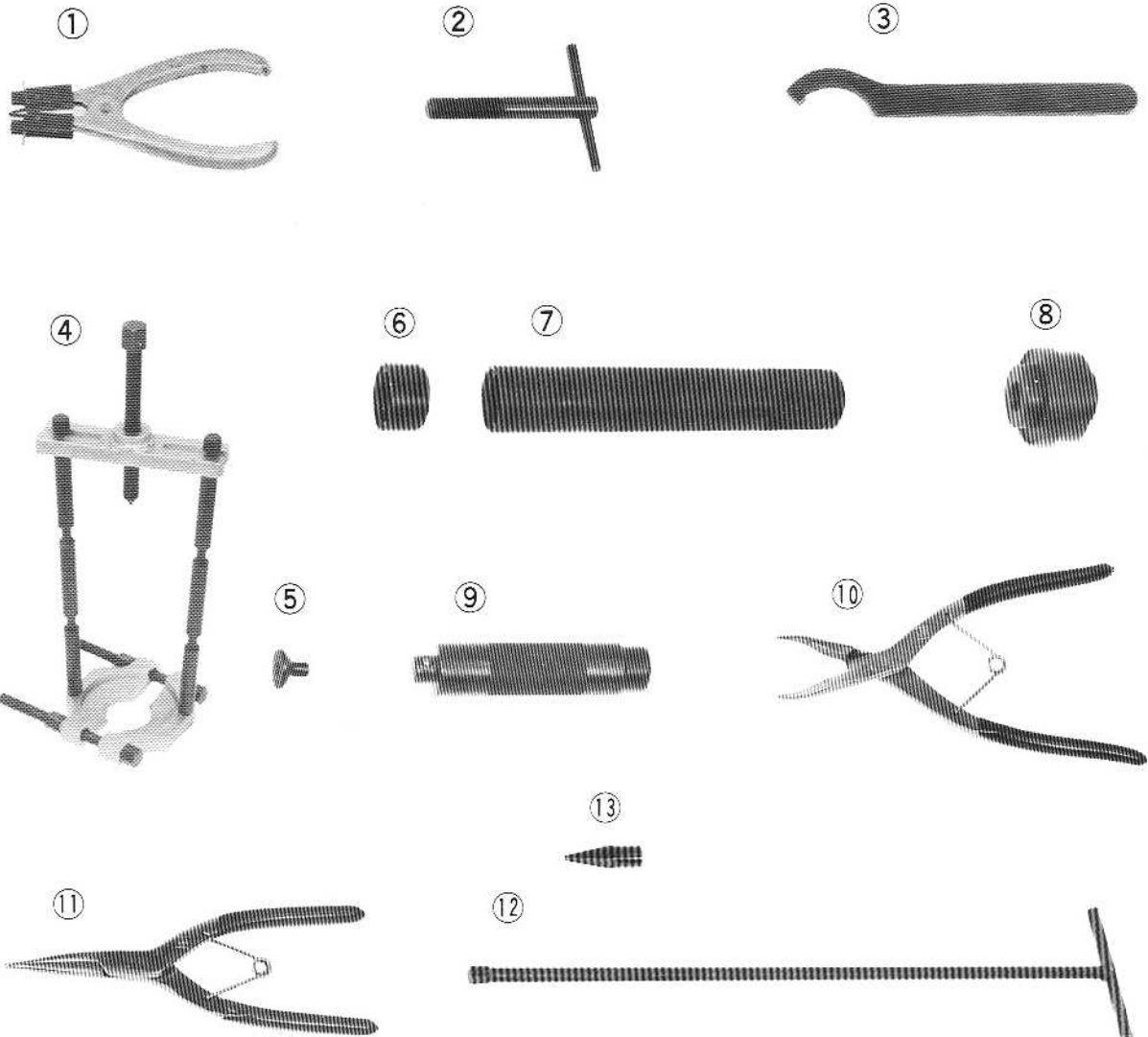

| REF. NO. | PART NO. | DESCRIPTION | Q'TY |
|----------|------------------------------------|-------------------------------------|------|
| 1 | 57001-115 | PISTON RING PLIERS | 1 |
| 2 | 57001-1016 (or P/NO. 57001-116) | ROTOR PULLER | 1 |
| 3 | 57001-134 | STEM NUT WRENCH | 1 |
| 4 | 57001-135 (or P/NO. 57001-158) | BEARING PULLER | 1 |
| 5 | 57001-166 (or P/NO. 57001-317) | BEARING PULLER ADAPTER | 1 |
| 6 | 57001-294 | STEM BEARING ADAPTER | 1 |
| 7 | 57001-137 | STEM BEARING DRIVER | 1 |
| 8 | 57001-138 | STEM CUP DRIVER | 1 |
| 9 | 57001-139 | BEARING DRIVER HOLDER | 1 |
| 10 | 57001-143 | INSIDE CIRCLIP PLIERS | 1 |
| 11 | 57001-144 | OUTSIDE CIRCLIP PLIERS | 1 |
| 12 | 57001-183 | FRONT FORK CYLINDER HOLDER HANDLE | 1 |
| 13 | 57001-1011 | FORK CYLINDER HOLDER HANDLE ADAPTER | 1 |

M

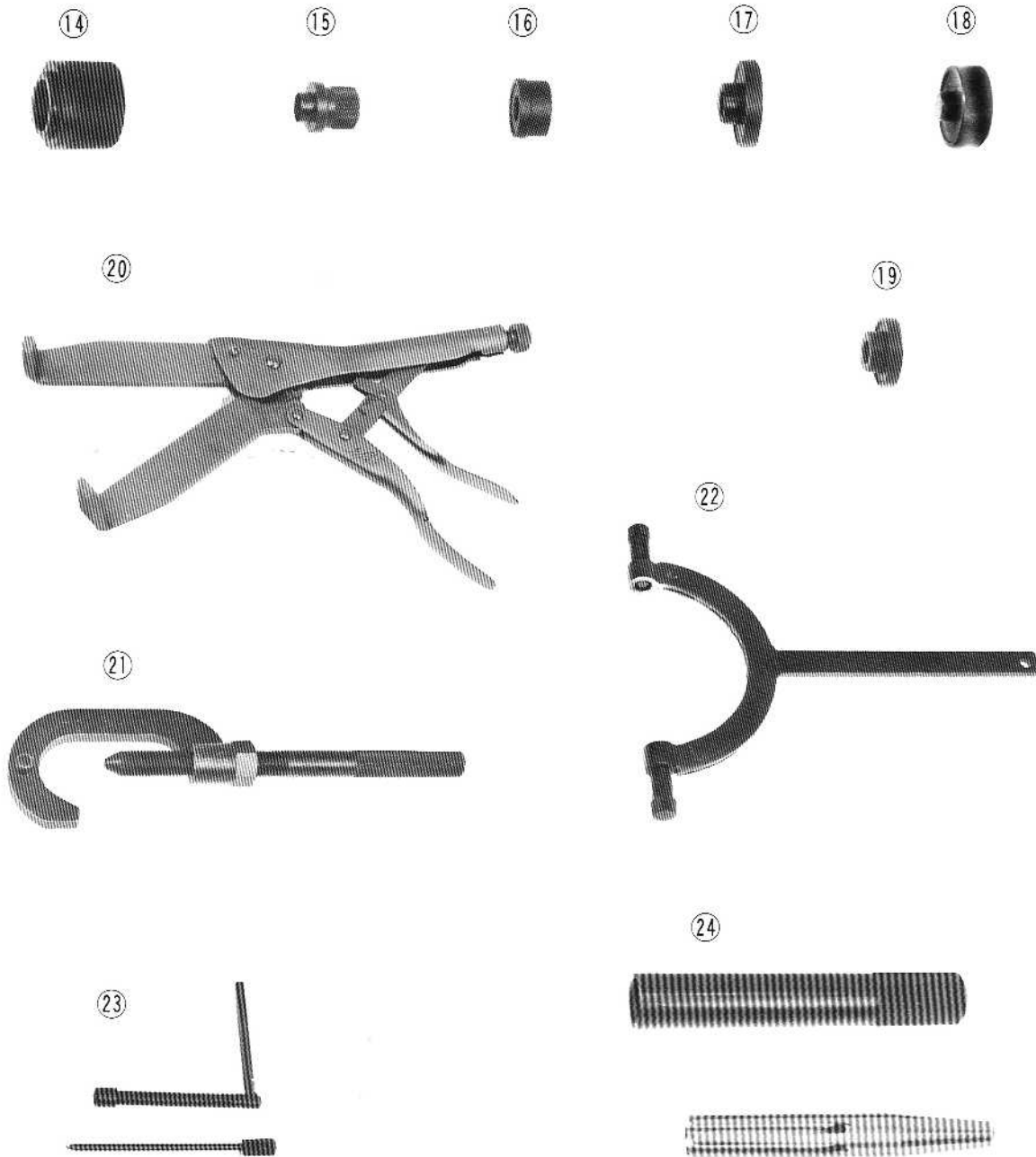

| REF. NO. | PART NO. | DESCRIPTION | Q'TY |
|----------|-----------|-----------------------------|------|
| 14 | 57001-191 | FRONT FORK OIL SEAL DRIVER | 1 |
| 15 | 57001-264 | OIL SEAL GUIDE | 1 |
| 16 | 57001-284 | BEARING DRIVER | 1 |
| 17 | 57001-289 | BEARING DRIVER | 1 |
| 18 | 57001-290 | BEARING DRIVER | 1 |
| 19 | 57001-291 | BEARING DRIVER | 1 |
| 20 | 57001-305 | CLUTCH HOLDER | 1 |
| 21 | 57001-307 | ENGINE SPROCKET HOLDER | 1 |
| 22 | 57001-308 | FLYWHEEL HOLDER | 1 |
| 23 | 57001-351 | BALANCE ADJUSTER | 1 |
| 24 | 57001-380 | TRANSMISSION CIRCLIP DRIVER | 1 |

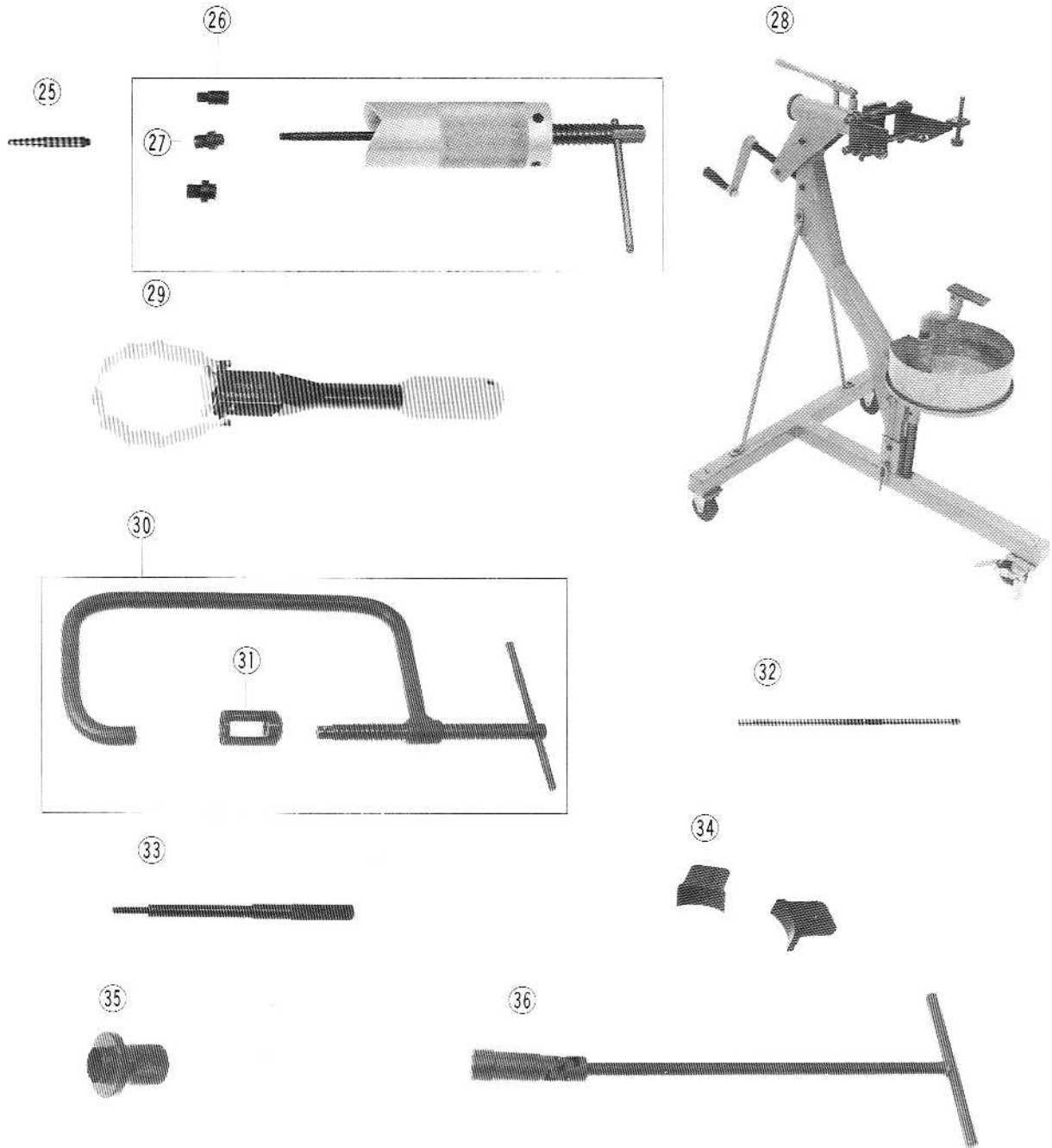

| REF NO. | PART NO. | DESCRIPTION | Q'TY |
|---------|------------|----------------------------------|-------|
| 25 | 57001-401 | VACUUM GAUGE ADAPTER | 2 |
| 26 | 57001-910 | PISTON PIN PULLER ASSEMBLY | 1 |
| 27 | 57001-913 | PISTON PIN PULLER ADAPTER "B" | 1 |
| 28 | 57001-900 | ENGINE STAND | 1 |
| 29 | 57001-921 | PISTON RING COMPRESSOR ASSEMBLY | 2 |
| 30 | 57001-241 | VALVE SPRING COMPRESSOR ASSEMBLY | 1 |
| 31 | 57001-1019 | VALVE SPRING COMPRESSOR ADAPTER | 1 |
| 32 | 57001-1020 | VALVE GUIDE REAMER | 1 |
| 33 | 57001-1021 | VALVE GUIDE ARBOR | 1 |
| 34 | 57001-1023 | PISTON HOLDER | 2 SET |
| 35 | 57001-1022 | OIL SEAL DRIVER | 1 |
| 36 | 57001-1024 | SPARK PLUG WRENCH | 1 |

37

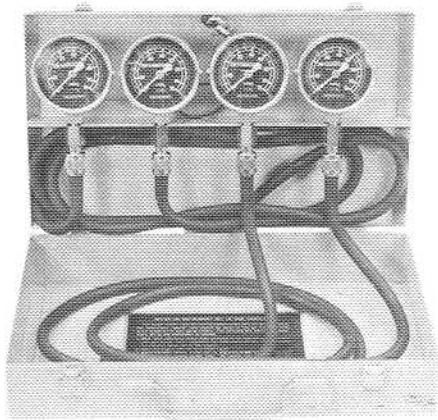

39



38



40



41



42



43



44

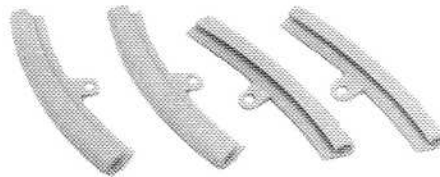

45



| REF. NO. | PART NO. | DESCRIPTION | Q'TY |
|----------|------------|--------------------------------|-------|
| 37 | 57001-127 | VACUUM GAUGE SET | 1 |
| 38 | 57001-221 | COMPRESSION GAUGE | 1 |
| 39 | 57001-980 | ELECTRO TESTER | 1 |
| 40 | 57001-983 | HAND TESTER | 1 |
| 41 | 57001-1081 | THICKNESS GAUGE | 1 |
| 42 | 57001-1017 | FUEL LEVEL GAUGE | 1 |
| 43 | 57001-1018 | COMPRESSION GAUGE ADAPTER HOSE | 1 |
| 44 | 57001-1063 | RIM PROTECTOR | 1 SET |
| 45 | 57001-1109 | ROTOR PULLER ADAPTER | 1 |

**Z250-A1,A2,A3,B1,B2 Wiring Diagram
(European and General Export Models)**

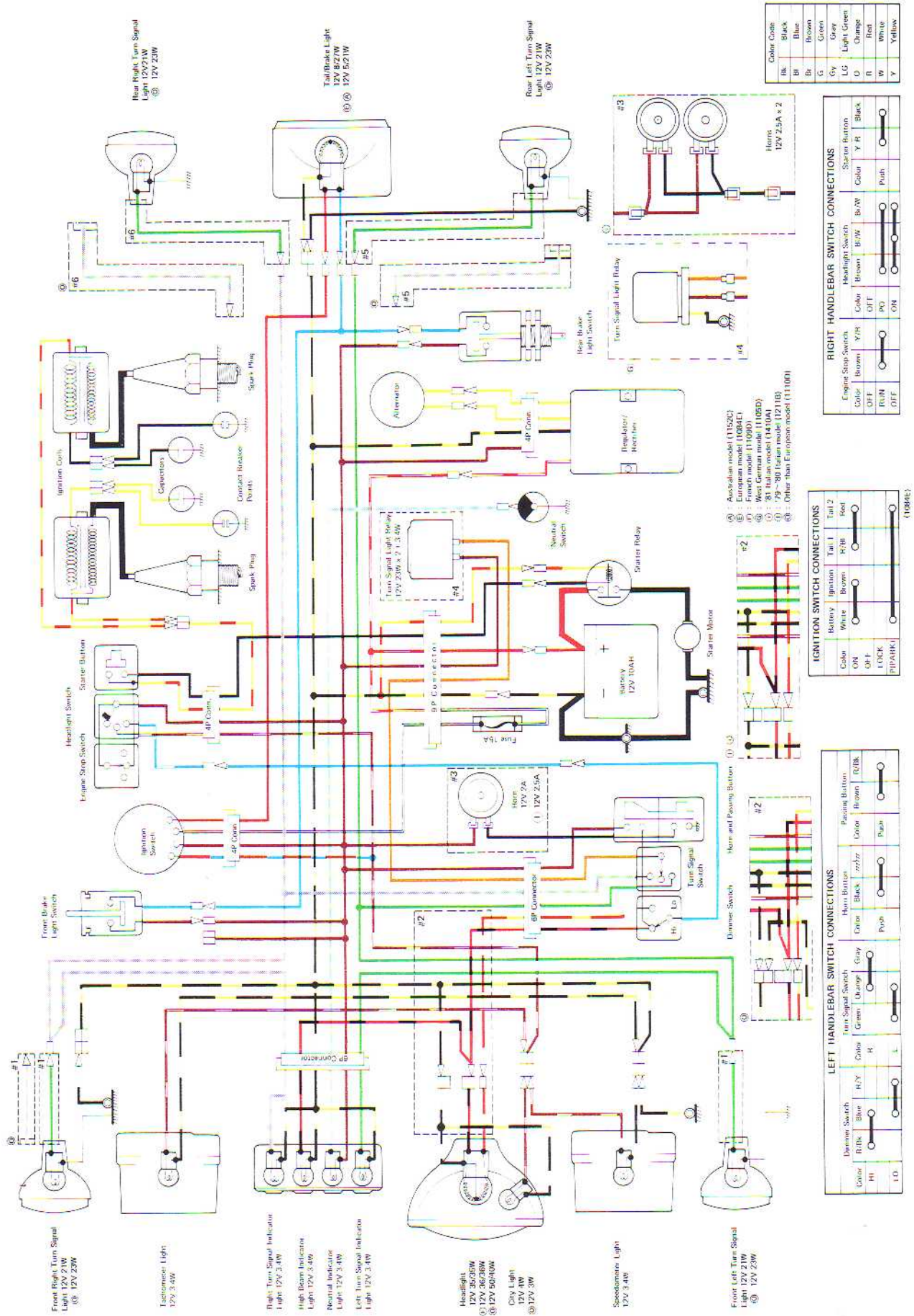

| Color Code | Color |
|------------|-------------|
| Blk | Black |
| Blu | Blue |
| Brn | Brown |
| G | Green |
| Gr | Gray |
| LG | Light Green |
| O | Orange |
| R | Red |
| Wh | White |
| Y | Yellow |

| Color | Function |
|-------|-------------|
| Blk | Start |
| Brn | Stop |
| Gr | Headlight |
| LG | Turn Signal |
| O | Ignition |
| R | Engine Stop |
| Wh | Neutral |
| Y | High Beam |

| Color | Function |
|-------|-------------|
| Blk | Start |
| Brn | Stop |
| Gr | Headlight |
| LG | Turn Signal |
| O | Ignition |
| R | Engine Stop |
| Wh | Neutral |
| Y | High Beam |

| Color | Function |
|-------|-------------|
| Blk | Start |
| Brn | Stop |
| Gr | Headlight |
| LG | Turn Signal |
| O | Ignition |
| R | Engine Stop |
| Wh | Neutral |
| Y | High Beam |

- (A) - Australian model (11052C)
- (B) - European model (10884C)
- (C) - West German model (11052D)
- (D) - 81 Italian model (1410A)
- (E) - 79-80 Italian model (1211B)
- (F) - Other than European model (11100)

Supplement

This Supplement is designed to be used in conjunction with the front part of this manual (up to Pg. 179). The maintenance and repair procedures described in this Supplement are only those that are unique to later year units since the first publication of this Service Manual. Complete and proper servicing of later year units therefore requires mechanics to read both this Supplement and the text in front of the Supplement.

This Supplement is divided into few sections. Each section is annually added to the preceding section, and explains procedures per one year unit that are unique to the latest year unit. Complete and proper servicing of later year units therefore requires mechanics to read (1) the section corresponding to the year unit they work at, (2) the previous section(s), and (3) the text in front of this Supplement.

Table of Contents

| | |
|------------------------------------|-----|
| SUPPLEMENT FOR 1980 Z250-A2 | 182 |
| SUPPLEMENT FOR 1980 Z250-B1 | 186 |
| SUPPLEMENT FOR 1981 Z250-A3 | 212 |
| SUPPLEMENT FOR 1981 Z250-B2 | 236 |
| SUPPLEMENT FOR 1981 KZ305-A1 | 240 |
| SUPPLEMENT FOR 1981 KZ305-C1 | 256 |
| SUPPLEMENT FOR 1982 Z250-A4 | 265 |
| SUPPLEMENT FOR 1982 Z250-B3 | 279 |
| SUPPLEMENT FOR 1982 KZ305-A2 | 283 |
| SUPPLEMENT FOR 1982 KZ305-B1 | 289 |
| SUPPLEMENT FOR 1982 KZ305-D1 | 299 |

Supplement for 1980 Z250-A2

Table of Contents

| | |
|---------------------------------------|-----|
| MODEL IDENTIFICATION | 183 |
| DISASSEMBLY | |
| TORQUE AND LOCKING AGENT | 184 |
| CARBURETORS | 184 |
| CYLINDER HEAD COVER, ROCKER ARM | 184 |
| CLUTCH | 184 |
| MAINTENANCE | |
| ROCKER ARMS, SHAFTS | 185 |
| CAMSHAFT | 185 |
| CYLINDER BLOCK, PISTONS | 185 |

Model Identification

Z250-A2 Left Side View

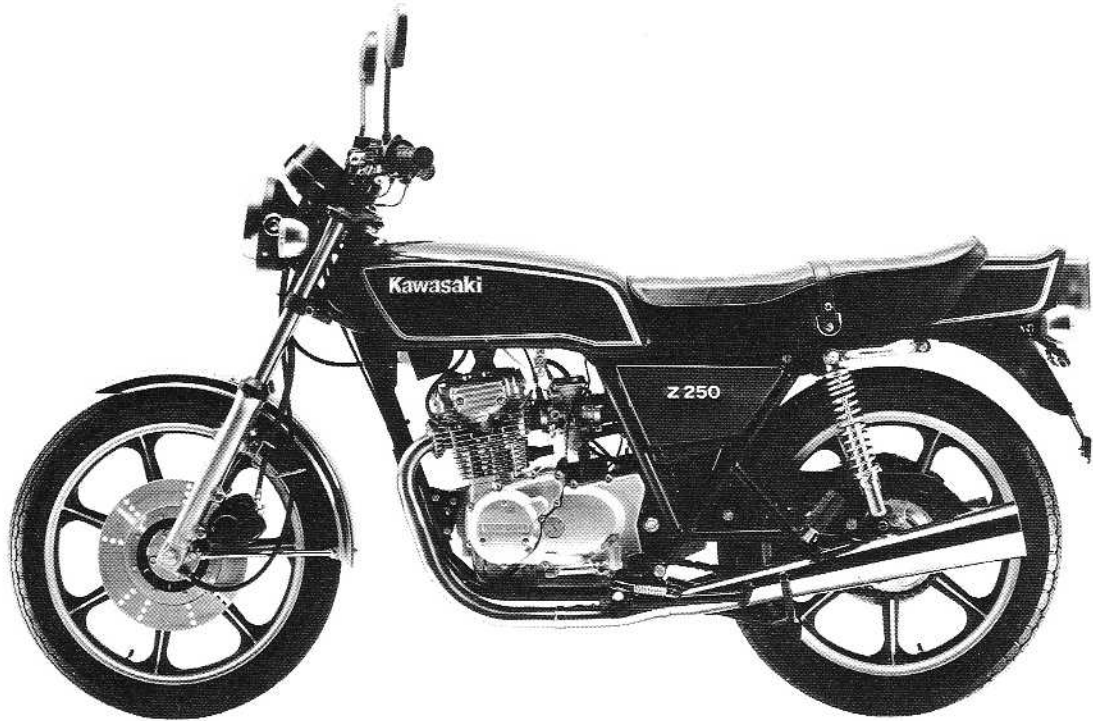

Z250-A2 Right Side View



Disassembly

TORQUE AND LOCKING AGENT

Engine Parts

Tighten the engine parts in accordance with the torque and locking agent table on Pgs. 33 and 34 with the following exceptions.

| Engine Part | Locking Agent (●) Required | Quantity | Metric (kg-m) | English (ft-lbs) | See Pg. |
|-----------------------|----------------------------|----------|---------------|------------------|---------|
| Rocker shafts | | | | | |
| left ϕ 10 P 1.0 | — | 2 | 3.0 | 22 | 184 |
| right ϕ 16 P 1.5 | — | 2 | 4.0 | 29 | 184 |

CARBURETORS

The procedures are the same as those for the 1979 Z250-A1 with the following exception. Refer to Pgs. 41 ~44.

Carburetor Disassembly and Assembly:

If the pilot screw limiters ④⑥ (Fig. E10 on Pg. 41) have been discontinued, install each pilot screw ④⑤ in the correct position as follows.

- Turn in the pilot screw fully but not tightly and then back it out 1 3/4 turns.

2. Replace the O rings on the right rocker shafts with new ones if it is deteriorated or damaged.
3. Tighten the rocker shafts (2) on the right side of the engine to 4.0 kg-m (29 ft-lbs) of torque, and the shafts (2) on the left side to 3.0 kg-m (22 ft-lbs) of torque.

CYLINDER HEAD COVER, ROCKER ARM

Removal and Installation:

For the cylinder head cover which has rocker shaft of a bolt type, observe the following notes referring to the procedures on Pgs. 44 ~ 47.

Rocker Shafts

(N1)

(a) Left-hand rocker shaft

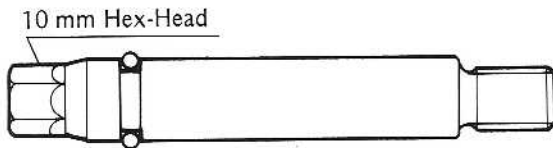

(b) Right-hand rocker shaft

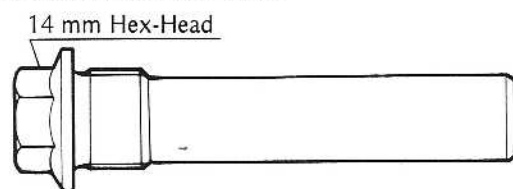

1. One of the 6 mm rocker cover bolts has been discontinued (# 2 bolt in Fig. E30 on Pg. 46 and Fig. F61 on Pg. 82). Tightening torque and order for the bolts are not changed.

CLUTCH

Removal and Installation:

The procedures are the same as those for the 1979 Z250-A1 with the following exception. Refer to Pgs. 62 ~64, and 79.

1. For the friction plates of which grooves are cut tangentially and radially, install them on the clutch housing so that the grooves run toward the center in the direction of the clutch housing rotation (counterclockwise viewed from the right side of the engine).

Friction Plate Installation

(N2)

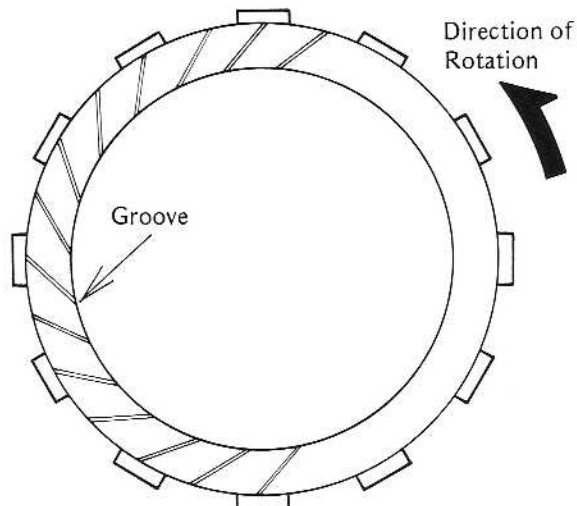

Maintenance

ROCKER ARMS, SHAFTS

The procedures are the same as those for the 1979 Z250-A1 with the following exception. Refer to Pg. 119.

Rocker arm/shaft wear

Table N1 Rocker Shaft Diameter

| | |
|---------------|----------|
| Service Limit | 12.94 mm |
|---------------|----------|

CAMSHAFT

The procedures are the same as those for the 1979 Z250-A1 with the following exception. Refer to Pgs. 119~121.

Journal wear

Table N2 Camshaft Journal/Cylinder Head Cover Clearance

| | |
|---------------|---------|
| Service Limit | 0.20 mm |
|---------------|---------|

CYLINDER BOLCK, PISTONS

The procedures are the same as those for the 1979 Z250-A1 with the following exception. Refer to Pgs. 127~130.

Piston ring, piston ring groove wear

Table N3 Piston Ring Thickness

| | Top Ring | 2nd Ring |
|---------------|----------|----------|
| Service Limit | 1.1 mm | 1.1 mm |

Table N4 Piston Ring Groove Width

| | Top Ring | 2nd Ring |
|---------------|----------|----------|
| Service Limit | 1.3 mm | 1.3 mm |

Supplement for 1980 Z250-B1

NOTE: The maintenance and repair procedures for the Z250B are newly included in this section. Unless otherwise noted, procedures for the 1980 model Z250-B1 are the same as those for their standard model 1979 Z250-A1.

Table of Contents

| | |
|---------------------------------------|-----|
| MODEL IDENTIFICATION | 187 |
| SPECIFICATIONS | |
| SPECIFICATIONS | 188 |
| ENGINE PERFORMANCE CURVES | 190 |
| PERIODIC MAINTENANCE CHART | 191 |
| ADJUSTMENT | |
| BRAKES | 192 |
| WHEEL BALANCE | 194 |
| LUBRICATION | 195 |
| DISASSEMBLY | |
| TORQUE AND LOCKING AGENT | 195 |
| CARBURETORS | 197 |
| MUFFLERS | 197 |
| CYLINDER HEAD COVER, ROCKER ARM | 197 |
| CLUTCH | 197 |
| FRONT WHEEL, BRAKE | 198 |
| REAR WHEEL, BRAKE, COUPLING | 202 |
| RIM | 205 |
| SPOKES | 206 |
| MAINTENANCE | |
| ROCKER ARMS, SHAFTS | 207 |
| CAMSHAFT | 207 |
| CYLINDER BLOCK, PISTONS | 207 |
| WHEELS | 207 |
| BRAKES | 209 |
| APPENDIX | |
| SPECIAL TOOLS | 211 |
| WIRING DIAGRAM | 211 |

Model Identification

Z250-B1 Right Side View

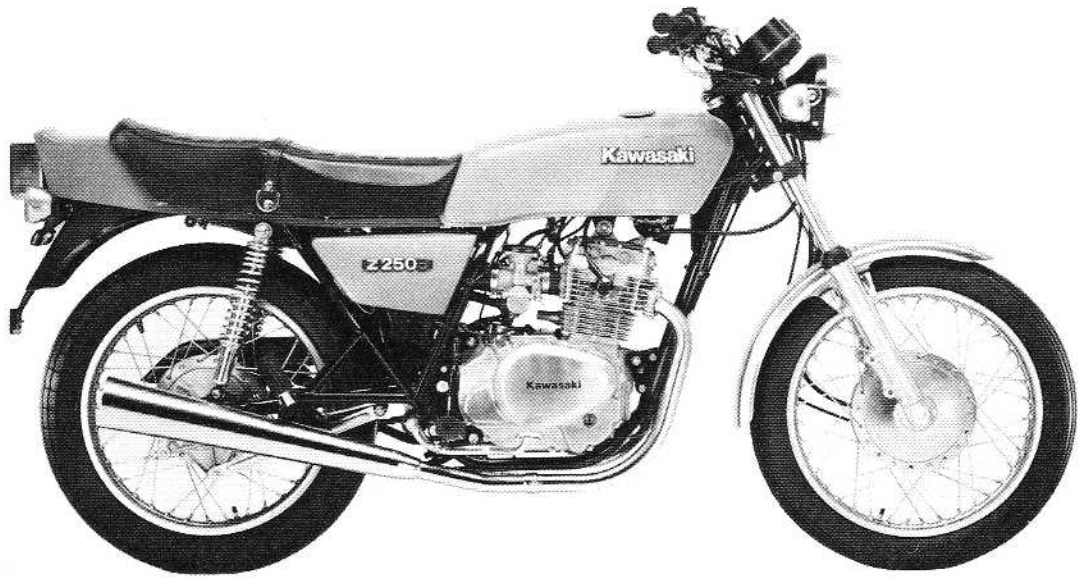

Z250-B1 Left Side View

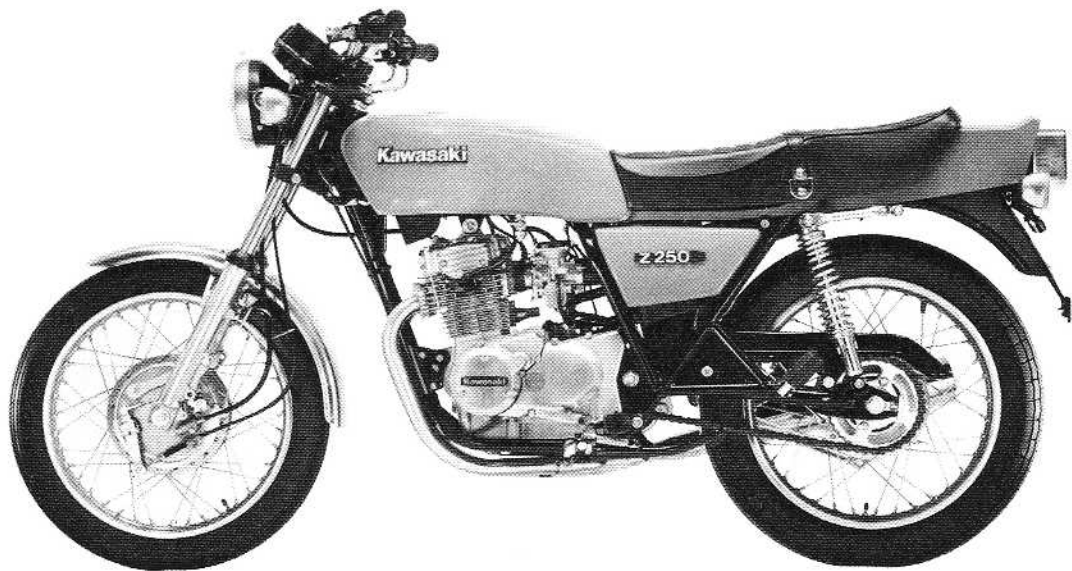

SPECIFICATIONS

Z250-B1

Dimensions

| | |
|--------------------|------------------------|
| Overall length | 2,020 mm, (A) 2,060 mm |
| Overall width | 705 mm |
| Overall height | 1,050 mm |
| Wheelbase | 1,340 mm |
| Road clearance | 155 mm |
| Dry weight | 145 kg |
| Fuel tank capacity | 13.6 ℓ |

Performance

| | |
|------------------------|--------------------|
| Climbing ability | 25° |
| Braking Distance | 14.0 m from 50 kph |
| Minimum turning radius | 2.2 m |

Engine

| | | |
|---------------------|--|----------|
| Type | SOHC, 2-cylinder, 4-stroke, air-cooled | |
| Bore and stroke | 55.0 x 52.4 mm | |
| Displacement | 248 cc | |
| Compression ratio | 9.5 | |
| Maximum horsepower | 27 HP @10,000 rpm | |
| Maximum torque | 2.1 kg-m @8,000 rpm | |
| Valve timing | | |
| Inlet | Open | 21° BTDC |
| | Close | 59° ABDC |
| | Duration | 260° |
| Exhaust | Open | 61° BBDC |
| | Close | 19° ATDC |
| | Duration | 260° |
| Carburetors | Keihin CV32 x 2 | |
| Lubrication system | Forced lubrication (wet sump) | |
| Engine oil | SE class SAE 10W40, 10W50, 20W40, or 20W50 | |
| Engine oil capacity | 1.8 ℓ (1.5 ℓ without filter change) | |
| Starting system | Electric starter | |
| Ignition system | Battery and coil | |
| Ignition timing | From 10° BTDC @1,250 rpm to 40° BTDC @3,000 rpm | |
| Spark plugs | NGK DR8ES or ND X24ESR-U (A) NGK D8EA or ND X24ES-U | |

Transmission

| | |
|-------------------------|--------------------------------------|
| Type | 6-speed, constant mesh, return shift |
| Clutch | Wet, multi disc |
| Gear ratio: 1st | 2.60 (39/15) |
| 2nd | 1.79 (34/19) |
| 3rd | 1.41 (31/22) |
| 4th | 1.16 (29/25) |
| 5th | 1.00 (27/27) |
| 6th | 0.89 (25/28) |
| Primary reduction ratio | 3.74 (71/19) |
| Final reduction ratio | 2.33 (35/15) |
| Overall drive ratio | 7.79 (Top gear) |

Electrical Equipment

| | |
|-------------------------|----------------------------|
| Alternator Rated Output | 13.5 amp. @8,000 rpm, 14V |
| Regulator/Rectifier | Shindengen SH221-12 |
| Ignition coil | Toyo denso ZC003-12V |
| Battery | Yuasa YB10L-A2 (12V 10AH) |
| Starter | Mistuba SM-725-1 |
| Headlight type | Semi-sealed |
| Headlight | 12V 35/35W, (A) 12V 50/40W |
| Tail/Brake light | 12V 5/21W |
| City light | 12V 4W |
| Turn signal lights | 12V 21W x 4 |
| Meter lights | 12V 3.4W x 2 |
| Indicator lights | 12V 3.4W x 4 |
| Horn | 12V 2A |

Frame

| | | |
|-------------------------------------|-------|------------------------|
| Type | | Tubular, single cradle |
| Steering angle | | 40° to either side |
| Castor | | 27° |
| Trail | | 100 mm |
| Tire size | Front | 3.00S-18 4PR |
| | Rear | 3.50S-18 4PR |
| Suspension | Front | Telescopic fork |
| | Rear | Swing arm |
| Wheel travel | Front | 150 mm |
| | Rear | 98 mm |
| Front fork oil capacity (each fork) | | 150 cc |
| Front fork oil type | | SAE 5W20 |

Brakes

| | | |
|---------------------------|-------|--------------------------------------|
| Type | Front | Internal expansion, two-leading |
| | Rear | Internal expansion, leading-trailing |
| Inside diameter and width | Front | 180 x 30 mm |
| | Rear | 160 x 30 mm |

(A) : Australian model

Specifications subject to change without notice, and may not apply to every country.

ENGINE PERFORMANCE CURVES (Z250-B1 ~ B3)

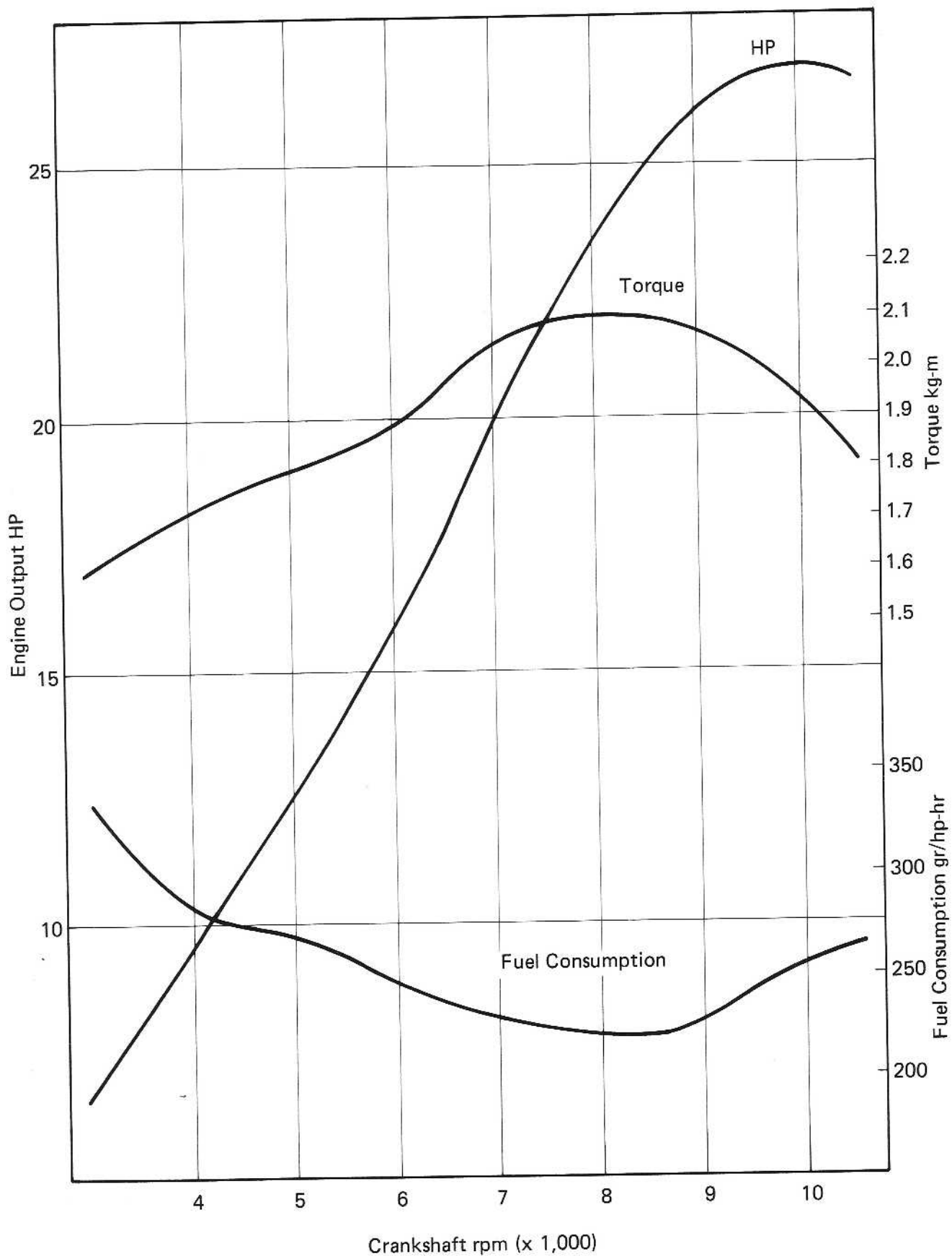

PERIODIC MAINTENANCE CHART (Z250-B1)

The maintenance and adjustments must be done in accordance with this chart to keep the motorcycle in good running condition. **The initial maintenance is vitally important and must not be neglected.**

| OPERATION | FREQUENCY | ODOMETER READING * | | | | | | | See Page |
|---|--------------|--------------------|----------|-----------|-----------|-----------|-----------|-----------|----------|
| | | 800 km | 5,000 km | 10,000 km | 15,000 km | 20,000 km | 25,000 km | 30,000 km | |
| Battery electrolyte level – check † | Every month | • | • | • | • | • | • | • | 156 |
| Brake adjustment – check † | | • | • | • | • | • | • | • | 192 |
| Brake wear – check † | | | • | • | • | • | • | • | 209 |
| Clutch – adjust | | • | • | • | • | • | • | • | 20 |
| Carburetors – adjust | | • | • | • | • | • | • | • | 18 |
| Throttle cables – adjust | | • | • | • | • | • | • | • | 17 |
| Steering play – check † | | • | • | • | • | • | • | • | 26 |
| Spoke tightness and rim runout – check † | | • | • | • | • | • | • | • | 207 |
| Drive chain wear – check † | | | • | • | • | • | • | • | 144 |
| Front fork – inspect/clean | | • | • | • | • | • | • | • | 151 |
| Rear shock absorbers – inspect | | • | • | • | • | • | • | • | 24 |
| Nuts, Bolts, Fasteners – check and torque | | • | | • | | • | | • | 195 |
| Spark plugs – clean and gap † | | • | • | • | • | • | • | • | 12 |
| Camshaft chain – adjust | | • | • | • | • | • | • | • | 16 |
| Points, timing – check † | | • | • | • | • | • | • | • | 12 |
| Valve clearance – check † | | • | • | • | • | • | • | • | 16 |
| Air cleaner element – clean | | | • | | • | | • | | 115 |
| Air cleaner element– replace | 5 cleanings | | | • | | • | | • | 115 |
| Fuel system– clean | | • | • | • | • | • | • | • | 22 |
| Tire tread wear – check † | | | • | • | • | • | • | • | 140 |
| Engine oil – change | year | • | • | • | • | • | • | • | 22 |
| Oil filter – change | | • | | • | | • | | • | 22 |
| General lubrication – perform | | | • | • | • | • | • | • | 195 |
| Front fork oil – change | | | | • | | • | | • | 152 |
| Timing advancer – lubricate | | | | • | | • | | • | 162 |
| Swing arm – lubricate | | | | • | | • | | • | 30 |
| Wheel bearings – grease | 2 years | | | | | • | | | 143 |
| Speedometer gear housing – grease | 2 years | | | | | • | | | 209 |
| Brake camshafts – grease | 2 years | | | | | • | | | 210 |
| Steering stem bearings – grease | 2 years | | | | | • | | | 150 |
| Drive chain – lubricate | Every 300 km | | | | | | | | 144 |
| Drive chain – adjust | Every 800 km | | | | | | | | 24 |

* For higher odometer readings, repeat at the frequency interval established here.

† Replace, add or adjust if necessary.

Adjustment

BRAKES

Brake lining and drum wear, and cable stretch cause the brakes to go out of adjustment, increasing lever and pedal play and decreasing braking effectiveness. Front brake adjustment to compensate for this actually consists of following three adjustments: cam lever angle, brake shoe synchronization, and brake lever. Rear brake adjustment to compensate for this actually consists of three successive adjustments: brake pedal position, cam lever angle, and brake pedal travel.

If brake drag is detected during brake adjustment, disassemble the brake (Pg. 201 or 202), and inspect for wear or damage (Pg. 209). Also, if the brake lever or pedal does not return to its rest position quickly upon release, inspect the brake for wear or damage. If the brake has a soft, or "spongy feeling", make sure the brake panel is properly synchronized or centered. See "Brake Shoe Synchronization" (Pg. 202) or the "NOTE" in the front wheel installation procedure (Pg. 199).

On the outside of the front brake panel there is a brake lining wear indicator. Whenever the indicator has gone past **USABLE RANGE**, the brake shoes must be immediately replaced and the other brake parts examined. Adjustment alone cannot compensate for the wear of a brake worn past **USABLE RANGE**.

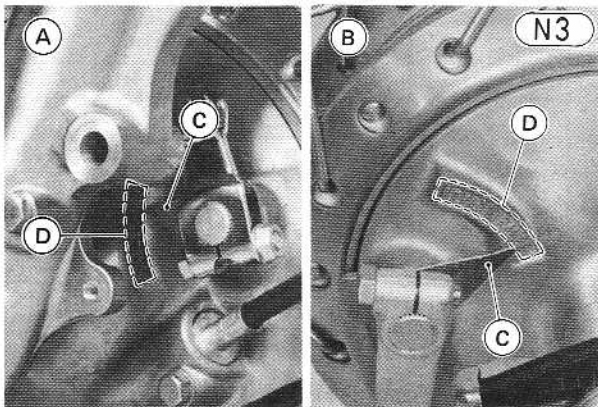

A. Front Brake
B. Rear Brake
C. Wear Indicator
D. **USABLE RANGE**

Front Brake

Cam Lever Angle

- When the brake is fully applied, the primary brake cam lever should come to an $80\sim 90^\circ$ angle with the threaded extension of the brake cable, at the same time as which the secondary brake cam lever should be parallel with the primary brake cam lever.
- If they do not, remove the cam levers and then remount them at new positions on the shafts to achieve the proper angle, or loosen the locknut and turn the connecting rod to make the two cam levers parallel.

WARNING Since a cam lever angle greater than 90° reduces braking effectiveness, this adjustment should not be neglected. When remounting the

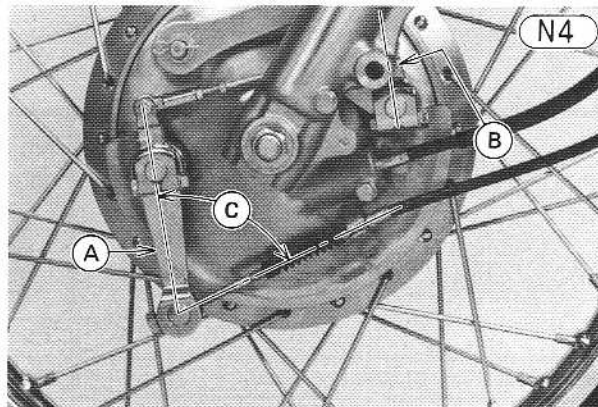

A. Primary Brake Cam Lever
B. Secondary Brake Cam Lever
C. $80\sim 90^\circ$

cam, be sure that the position of the indicator on the serrated shaft is not altered. See Pg. 201 for detailed information on the position of the wear indicator when the cam lever is not on the shaft. A change in cam lever angle is caused by wear of internal brake parts. Whenever the cam lever angle is adjusted, also check for drag and proper lever operation, taking particular note of the brake lining wear indicator position. In case of doubt as to braking effectiveness, disassemble and inspect all internal brake parts. Worn parts could cause the brake to lock or fail.

- Rotate the wheel to check for brake drag.
- Operate the brake lever a few times to see that it returns to its rest position immediately upon release.
- Adjust the front brake lever.

Brake Shoe Synchronization

After the front wheel is removed, or after the brake was disassembled, synchronize the brake shoes.

- Raise the front wheel off the ground by some means.
- Loosen the locknut and turn the connecting rod one turn clockwise. This procedure backs off the secondary brake shoe so that it will not operate when the primary shoe contacts the inside surface of the drum.

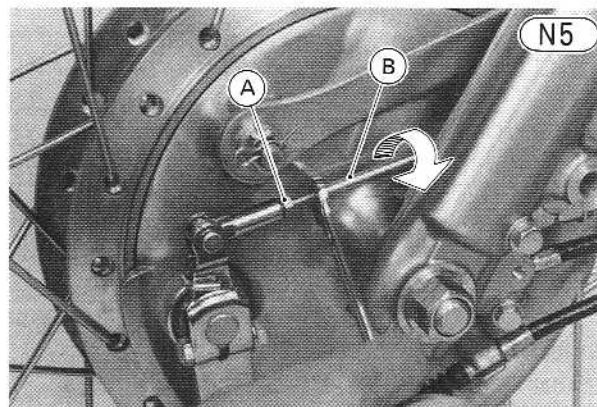

A. Locknut
B. Connecting Rod

- While spinning the wheel lightly, turn in the adjusting nut and/or turn out the adjuster at the front brake lever until the primary shoe just starts touching the drum. When the shoe starts touching the drum, light dragging can be felt or heard.

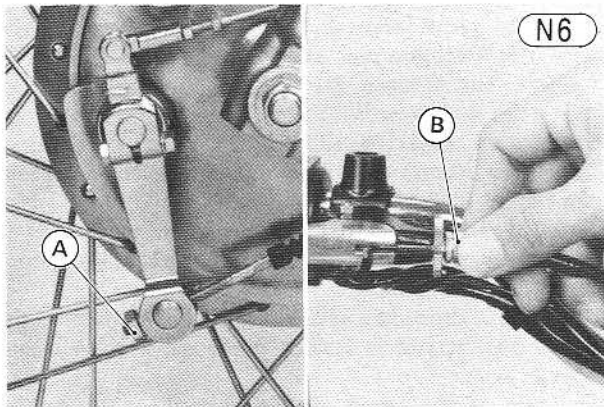

A. Adjusting Nut B. Adjuster

- Spinning the wheel lightly, turn the connecting rod counterclockwise until the secondary brake shoe just starts dragging on the drum, and then tighten the locknut.

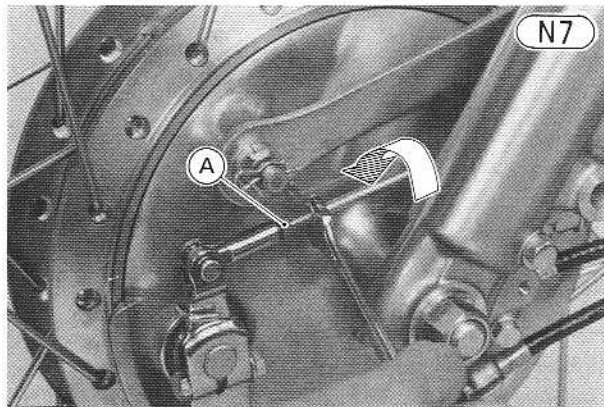

A. Locknut

- Adjust the front brake lever.

Front Brake Lever

- Loosen the knurled locknut at the front brake lever, turn the adjuster fully in, and tighten the locknut.

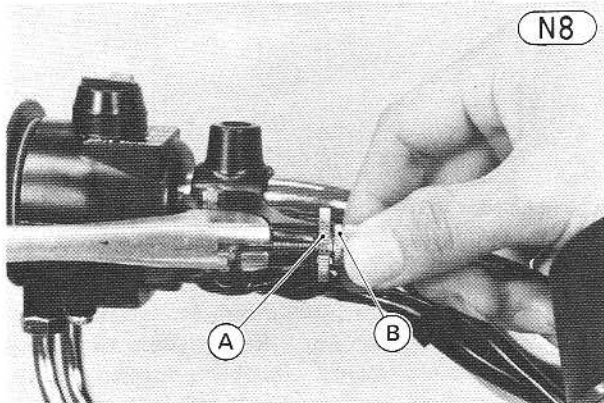

A. Knurled Locknut B. Adjuster

- Turn the adjusting nut on the lower end of the front brake cable so that the brake lever will have 4~5 mm of play as shown in the figure.

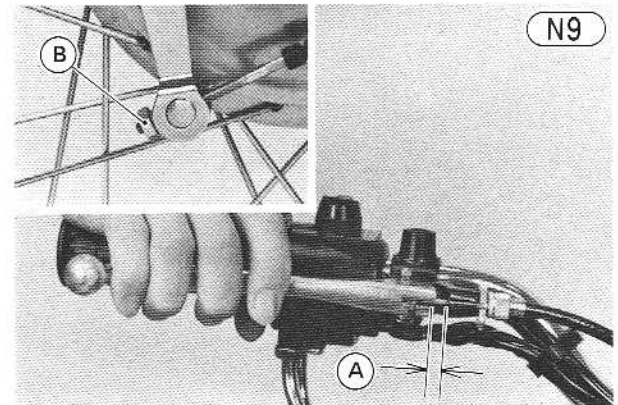

A. 4~5 mm B. Adjusting Nut

- If sufficient adjustment cannot be made with the adjusting nut at the lower end of the brake cable, complete the adjustment with the adjuster at the brake lever, and then tighten the locknut.
- Check for brake drag.
- Operate the lever a few times to see that it returns to its rest position immediately upon release.
- For minor corrections, use the adjuster at the front brake lever.

Rear Brake

Brake Pedal Position

- When the brake pedal is in its rest position, it should be 0~30 mm lower than the top of the footpeg. If it is too high, turn out the adjusting nut at the end of the brake rod to give the brake pedal plenty of play. If it is too low, go to the next step.

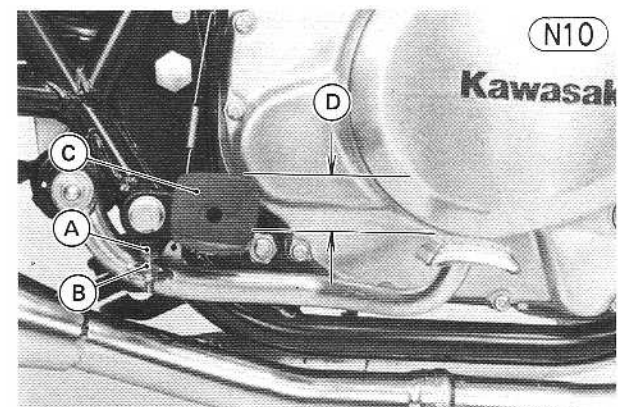

A. Adjusting Bolt C. Footpeg
B. Locknut D. 0~30 mm

- Loosen the locknut, turn the adjusting bolt to obtain the correct pedal position, and tighten the locknut.
- Check the brake pedal travel.
- Check the rear brake light switch operation.

Cam Lever Angle

- When the brake is fully applied, the brake cam lever should come to an 80~90° angle with the brake rod.

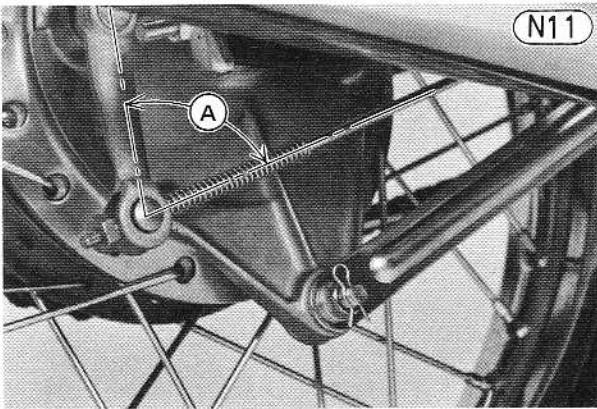

A. 80~90°

- If it does not, remove the cam lever, and then remount it at a new position on the shaft for the proper angle.

WARNING Since a cam lever angle greater than 90° reduces braking effectiveness, this adjustment should not be neglected. When remounting the cam, be sure that the position of the indicator on the serrated shaft is not altered. See Pg. 203 for detailed information on the position of the wear indicator when the cam lever is not on the shaft. A change in cam lever angle is caused by wear of internal brake parts. Whenever the cam lever angle is adjusted, also check for drag and proper pedal operation, taking particular note of the brake lining wear indicator position. In case of doubt as to braking effectiveness, disassemble and inspect all internal brake parts. Worn parts could cause the brake to lock or fail.

- Rotate the rear wheel to check for brake drag.
- Operate the pedal a few times to see that it returns to its rest position immediately upon release.
- Adjust the brake pedal travel.

Brake Pedal Travel

- Check to see that the brake pedal has 20~30 mm of travel from the rest position to the fully applied position when the brake pedal is pushed down lightly by hand.

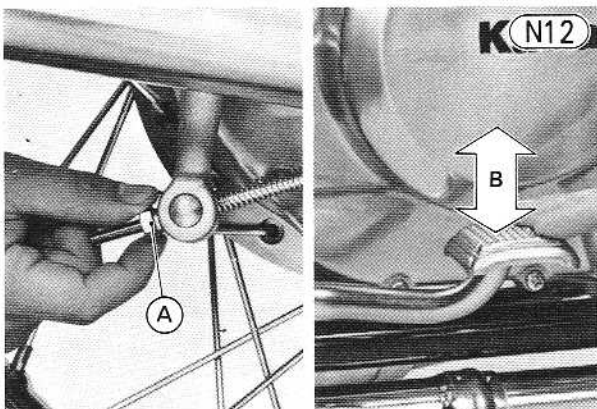

A. Adjusting Nut

B. 20~30 mm

- If it does not, turn the adjusting nut on the end of the brake rod so that the brake pedal has the proper travel.

- Rotate the rear wheel to check for brake drag.
- Operate the pedal a few times to see that it returns to its rest position immediately upon release.
- Check the rear brake light switch operation.

WHEEL BALANCE (Wire-spoke Wheel)

To improve stability and decrease vibration at high speed, the front and rear wheels must be kept balanced.

Check and balance the wheels when required, or when a tire is replaced with a new one.

- Remove the wheel (Pg. 198 or 202).
- Check the all the spokes are tightened evenly and the rim runout is within the service limit (Pg. 207).
- Suspend the wheel so that it can be spun freely.
- Spin the wheel lightly, and mark the spoke at the top when the wheel stops.
- Repeat this procedure several times. If the wheel stops of its own accord in various positions, it is well balanced.
- However, if the wheel always stops in one position, attach a balance weight loosely to the marked spoke.

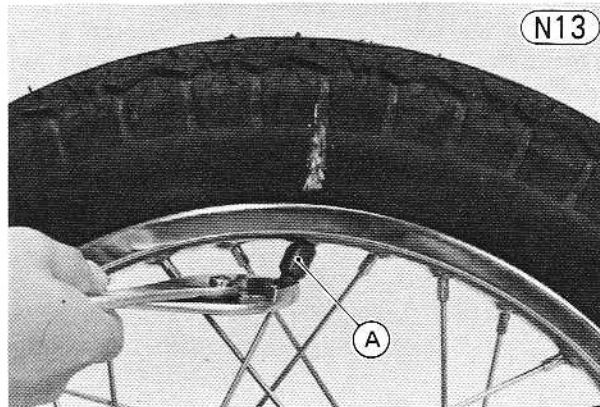

A. Balance Weight

- Rotate the wheel ¼ turn, and see whether or not the wheel stays in this position. If it does, the correct balance weight is being used.

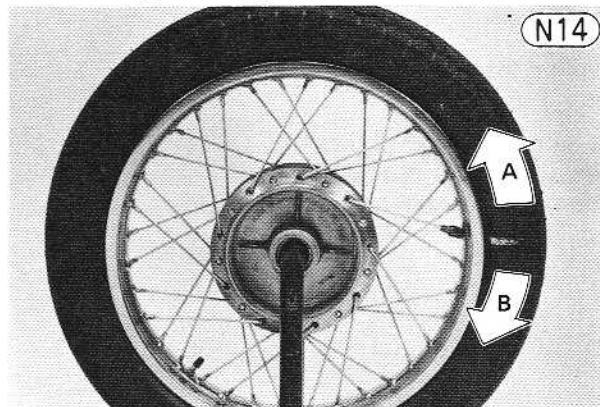

A. Use heavier size

B. Use lighter size

- If the wheel rotates and the weight goes up, replace the weight with the next heavier size. If the wheel rotates and the weight goes down, replace the weight with the next lighter size. Repeat these steps until the wheel remains at rest after being rotated ¼ turn.
- Rotate the wheel another ¼ turn and then another ¼ turn to see if the wheel is correctly balanced.

- Repeat the entire procedure as many times as necessary to achieve correct wheel balance, and then clamp on the balance weights firmly using pliers.
- Mount the wheel back onto the motorcycle (Pg. 198 or 202).

NOTE: Balance weights are available from Kawasaki Dealers in 5, 10, 20, and 30 gram sizes. An imbalance of less than 10 grams will not usually affect running stability.

LUBRICATION

In addition to the points listed in Pgs. 29 ~ 30 lubricate regularly the following parts.

Front Brake Parts

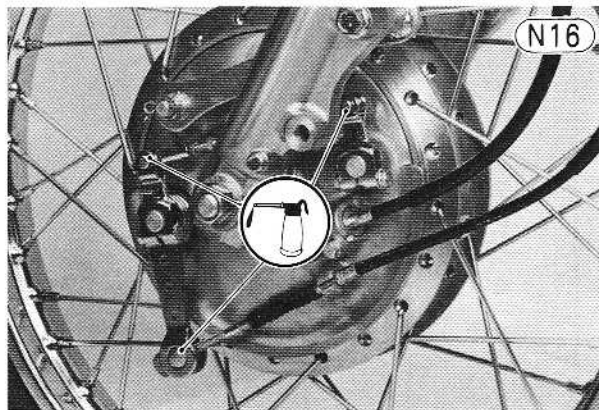
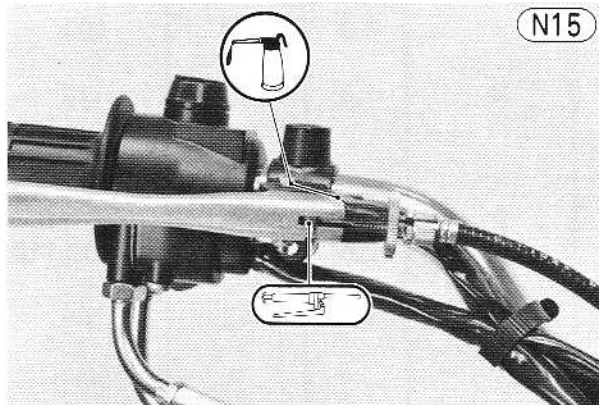

Rear Brake Parts

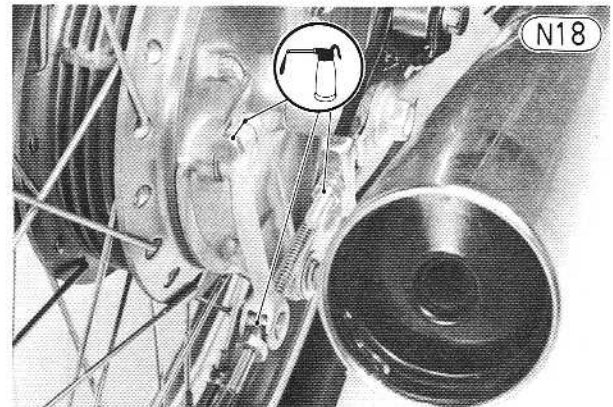
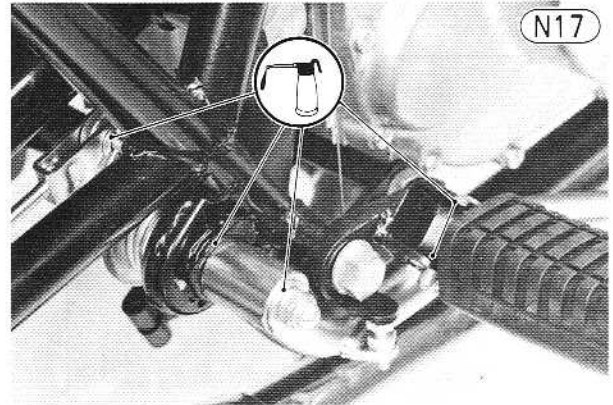

Disassembly

TORQUE AND LOCKING AGENT

Engine Parts

Tighten the engine parts in accordance with the torque and locking agent table on Pgs. 33 and 34 with the following exceptions.

| Engine Part | Locking Agent (●) Required | Quantity | Metric (kg-m) | English (ft-lbs) | See Pg. |
|----------------------|----------------------------|----------|---------------|------------------|---------|
| Rocker shafts | | | | | |
| left ϕ 10 P1.0 | — | 2 | 3.0 | 22 | 197 |
| right ϕ 16 P1.5 | — | 2 | 4.0 | 29 | 197 |

Frame Parts

Tighten the frame parts of the Z250-B to the torque listed in the following table.

| Frame Part | Locking Agent (•), Liquid Gasket (*) Required | Quantity | Metric (kg-m) | English (ft-lbs) | See Pg. |
|--|---|----------|---------------|------------------|------------|
| † Brake pedal pivot cap nut ϕ 8 P1.25 | — | 1 | 2.0 | 14.5 | — |
| † Front fender mounting bolts ϕ 8 P1.25 | — | 4 | — | — | — |
| † Front axle nut ϕ 14 P1.5 | — | 1 | 6.0 | 43 | 199 |
| Front fork bottom Allen bolts ϕ 10P1.0 | •, * | 2 | 1.8 | 13.0 | 112 |
| † Front fork clamp bolts upper ϕ 8 P1.25 | — | 2 | 1.8 | 13.0 | 108, 110 |
| lower ϕ 10 P1.25 | — | 2 | 2.5 | 18.0 | 27,108,110 |
| † Handlebar clamp bolts ϕ 8 P1.25 | — | 4 | 1.8 | 13.0 | 105 |
| † Clutch lever pivot bolt ϕ 6 P1.0 | — | 1 | — | — | — |
| † Front brake lever pivot bolt ϕ 6 P1.0 | — | 1 | — | — | — |
| Rear axle nut ϕ 16 P1.5 | — | 1 | 9.0 | 65 | — |
| † Rear shock absorber mounting upper cap nuts ϕ 10 P1.25 | — | 2 | 3.0 | 22 | — |
| lower bolts ϕ 10 P1.25 | — | 2 | 3.0 | 22 | — |
| Rear sprocker nuts ϕ 10 P1.25 | — | 4 | 3.0 | 22 | 99 |
| † Side stand bolt ϕ 10 P1.25 | — | 1 | — | — | — |
| † Footpeg mounting bolts ϕ 12 P1.25 | — | 2 | — | — | — |
| Spokes | — | 76 | 0.30 | 26 in-lbs | 206 |
| † Steering stem head bolt ϕ 16 P1.5 | — | 1 | 5.5 | 40 | 27,108 |
| † Steering stem head clamp bolt ϕ 8 P1.25 | — | 1 | 1.8 | 13.0 | 27 |
| † Steering stem locknut ϕ 30 P1.0 | — | 1 | 3.0 | 22 | 27,108 |
| † Swing arm pivot shaft nut ϕ 14 P1.5 | — | 1 | 8.0 | 58 | — |
| † Torque link nuts ϕ 10 P1.25 | — | 4 | 3.0 | 22 | — |

CARBURETORS

The procedures are the same as those for the 1979 Z250-A1 with the following exception. Refer to Pgs. 41 ~ 44.

Carburetor Disassembly and Assembly:

If the pilot screw limiters 46 (Fig. E10 on Pg. 41) have been discontinued, install each pilot screw 45 in the correct position as follows.

- Turn in the pilot screw fully but not tightly and then back it out 1 3/4 turns.

MUFFLER

Removal:

- Loosen the exhaust pipe clamp bolt.

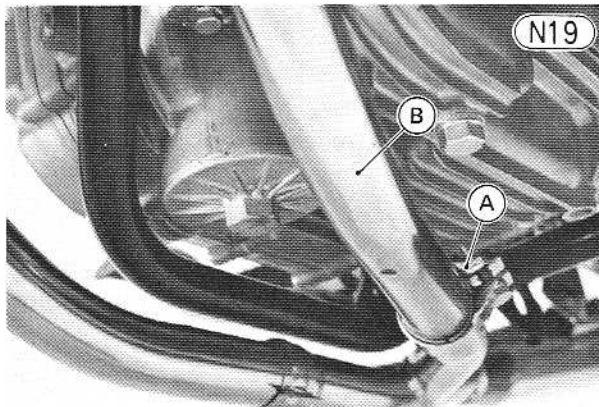

A. Clamp B. Exhaust Pipe

- Remove the exhaust pipe holder nuts (4), and slide the holders (2) off the studs.

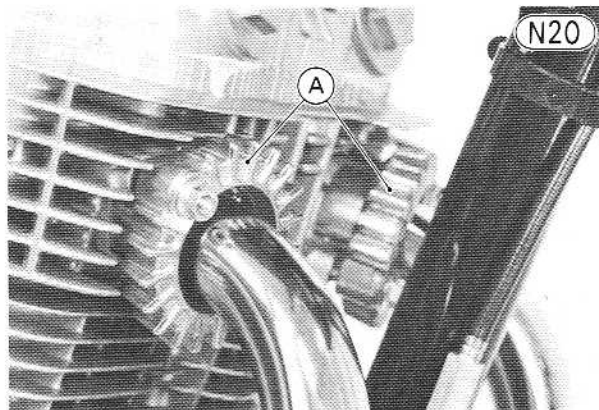

A. Exhaust Pipe Holder

- Remove the split keeper, and pull the left exhaust pipe off the muffler and cylinder head.
- Unscrew the mounting nut of the rear footpeg on the right side, and remove the muffler and right exhaust pipe (single unit) off the chassis.
- Take the gasket out of the exhaust port in the cylinder head.

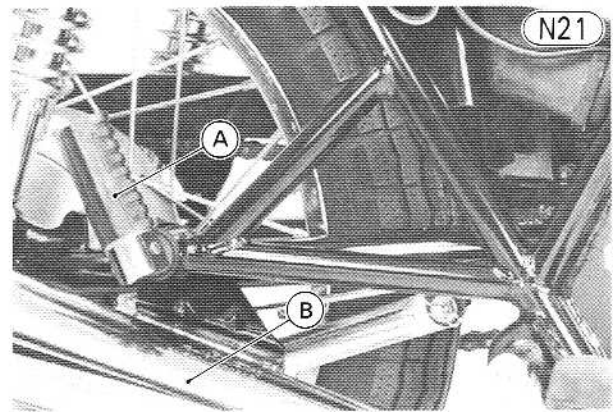

A. Rear Footpeg B. Muffler

Installation Notes:

1. Replace the gaskets with new ones.
2. First, tighten all the clamp bolt and mounting nuts with finger tight; secondly, tighten the exhaust pipe holder nuts (4) evenly to avoid an exhaust leak; and then tighten the rear footpeg mounting nut and exhaust pipe clamp bolt.

CYLINDER HEAD COVER, ROCKER ARM

Removal and Installation:

For the cylinder head cover which has rocker shaft of a bolt type, observe the following notes referring to the procedures on Pgs. 44 ~ 47.

Rocker Shafts

N22

(a) Left-hand rocker shaft

10 mm Hex-Head

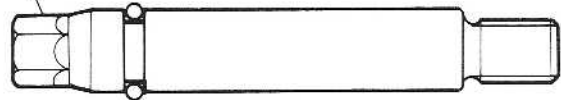

(b) Right-hand rocker shaft

14 mm Hex-Head

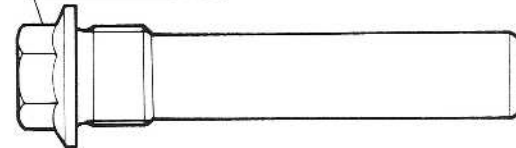

1. One of the 6 mm rocker cover bolts has been discontinued (# 2 bolt in Fig. E30 on Pg. 46 and Fig. F61 on Pg. 82). Tightening torque and order for the bolts are not changed.
2. Replace the O rings on the right rocker shafts with new ones if it is deteriorated or damaged.
3. Tighten the rocker shafts (2) on the right side of the engine to 4.0 kg-m (29 ft-lbs) of torque, and the shafts (2) on the left side to 3.0 kg-m (22 ft-lbs) of torque.

CLUTCH

Removal and Installation:

The procedures are the same as those for the Z250-A with the following exception. Refer to Pgs. 62~64, and 79.

1. For the friction plates of which grooves are cut tangentially and radially, install them on the clutch housing so that the grooves run toward the center in the direction of the clutch housing rotation (counterclockwise viewed from the right side of the engine).

Friction Plate Installation

N23

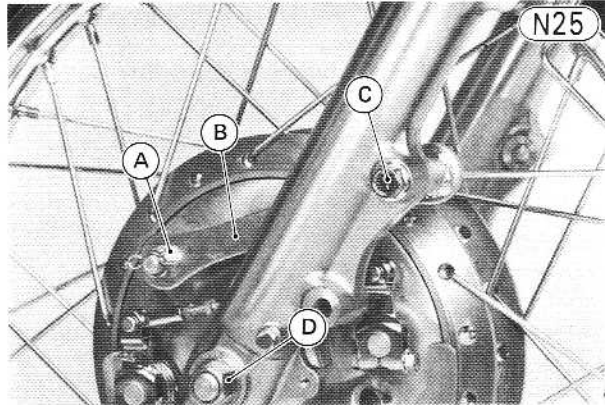
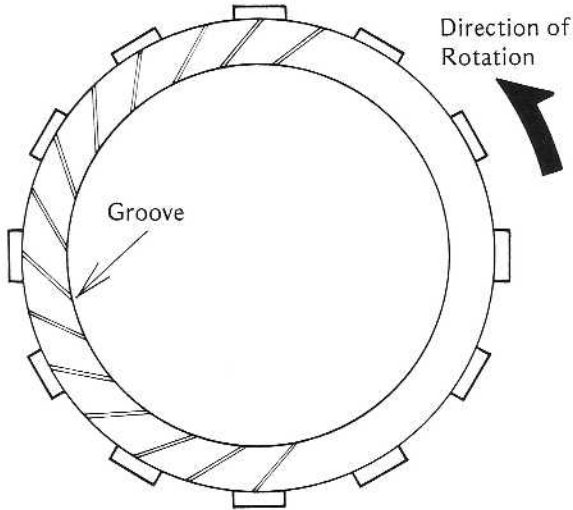

- A. Nut
- B. Torque Link
- C. Bolt
- D. Axle Nut

- Unscrew the front axle nut.
- Holding the wheel to facilitate axle removal, pull out the axle, and then remove the wheel from the motorcycle.

FRONT WHEEL, BRAKE

Removal:

- Jack or prop up the engine so that the front wheel is off the ground.
- Slide the cable dust cover out of its position on the outer cable end.
- Screw off the adjusting nut, and free the brake cable from the brake panel. Also remove the brake cable joint.

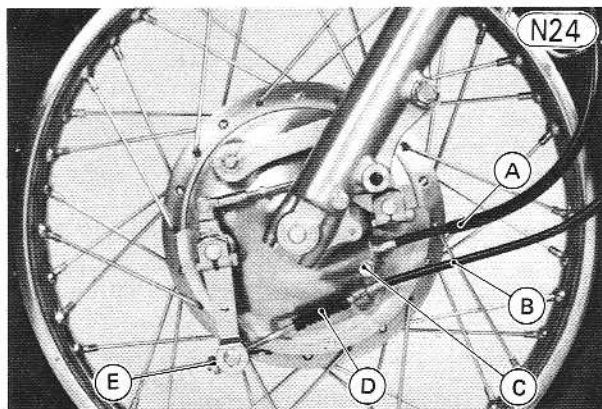

- A. Speedometer Cable
- B. Brake Cable
- C. Retaining Bolt
- D. Dust Cover
- E. Adjusting Nut

Installation:

- Hold the front wheel in place between the front fork tubes, and insert the axle from the right.
- Install the nut on the axle, and finger tighten it.
- Hook the lower end of the torque link on the brake panel.
- Hook the upper end of the torque link on the bolt that goes through the upper hole in the fork tube. Install the torque link with the welded collar side of the link facing the fork tube.

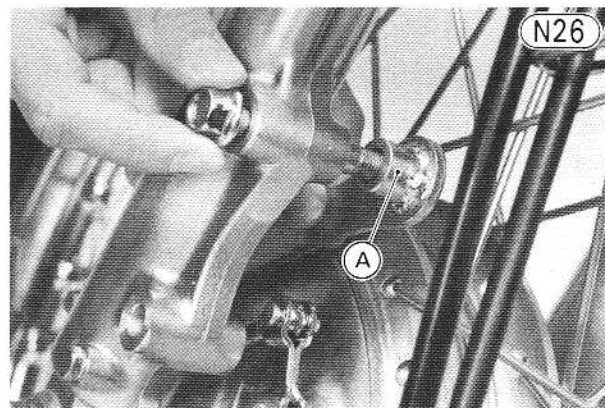

- A. Welded Collar

- Install the lockwasher, and nut on the bolt, and install the lockwasher and nut on the stud on the brake panel. Finger tighten the nuts.
- Center the brake panel assembly in the brake drum. This is done by tightening the axle lightly, spinning the wheel, and pulling the brake lever forcefully. The partially tightened axle allows the brake panel assembly to center itself within the brake drum.

NOTE: This procedure can prevent a soft, or "spongy feeling" brake.

- Holding the axle with an open end wrench so that it does not turn, tighten the axle nut to 6.0 kg m (43 ft-lbs) of torque.
- Tighten the torque link nuts to 3.0 kg-m (22 ft-lbs) of torque, and insert the torque link clips.
- Insert the speedometer inner cable into the front brake panel while turning the wheel so that the inner cable end will seat in the speedometer pinion gear.
- Install the speedometer cable retaining bolt and washer.
- Attach the brake cable, brake cable joint, and adjusting nut back onto the front brake panel.
- Slide the cable dust cover back into the groove on the brake outer cable end to secure the brake outer cable in the cable mount.

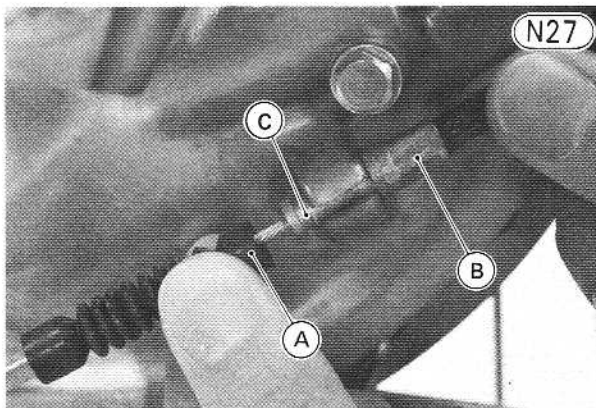

A. Dust Cover C. Groove
B. Brake Outer Cable

- Adjust the front brake (Pg. 192).

Speedometer Pinion Removal:

- Unscrew the speedometer pinion bushing 30 from the brake panel, and drop out the pinion 29 and washers 28.

Speedometer Pinion Installation:

- Grease the speedometer pinion, install the pinion and its washers, and screw in the speedometer pinion bushing securely.

Front Hub Disassembly:

- Pull the brake panel 9 and cap 31 off the front hub.
- Pull off the grease seal 14 on the cap side using a hook.

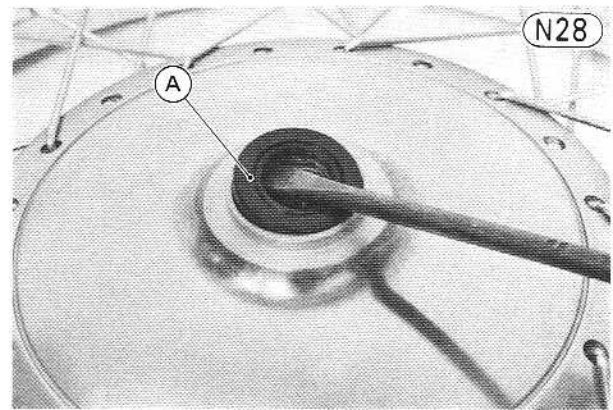

A. Grease Seal

- Insert a metal rod into the hub from the cap side and remove the bearing 15 by tapping evenly around its inner race. The distance collar 16 will come out with the bearing.

Bearing Removal

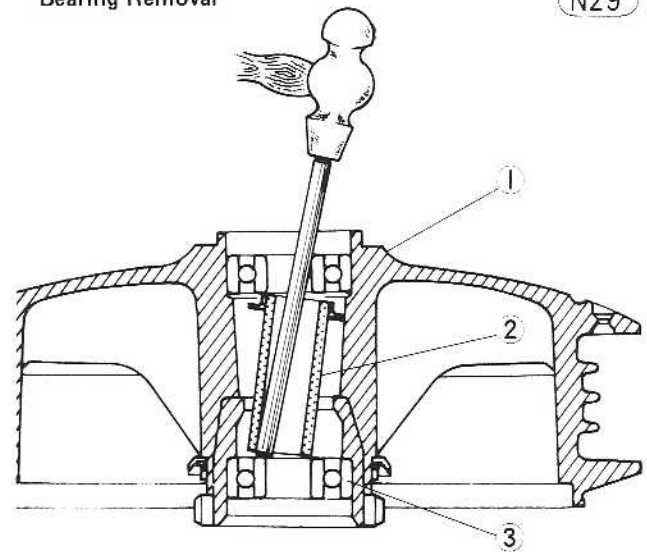

1. Front Hub 2. Distance Collar 3. Ball Bearing

- Insert a metal rod into the hub from the panel side, and remove the bearing 16 on the cap side by tapping evenly around its inner race.
- To remove the grease seal 14 on the panel side, pull off the speedometer gear 13 using a gear puller, and pull off the grease seal using a hook.

Front Hub Assembly:

- Using a suitable tool, install the panel side grease seal and the speedometer gear. Press them in until they stop at the shoulders on the hub.
- After installing the speedometer gear, punch two points on the drum to lock the gear in place.

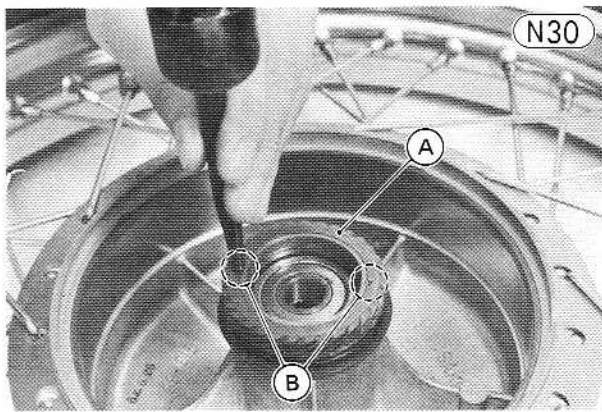

A. Speedometer Gear B. Punch two points

- Inspect the bearings and replace them if necessary (Pg. 143).
- Lubricate the ball bearings (Pg. 143).
- Before installing the wheel bearings, blow any dirt or foreign particles out of the hub with compressed air to prevent contamination of the bearings.
- Install the cap side ball bearing using the wheel bearing driver and the bearing driver holder (special tools). Press the bearing in until it stops at the bottom of the hole.

Front Hub

N31

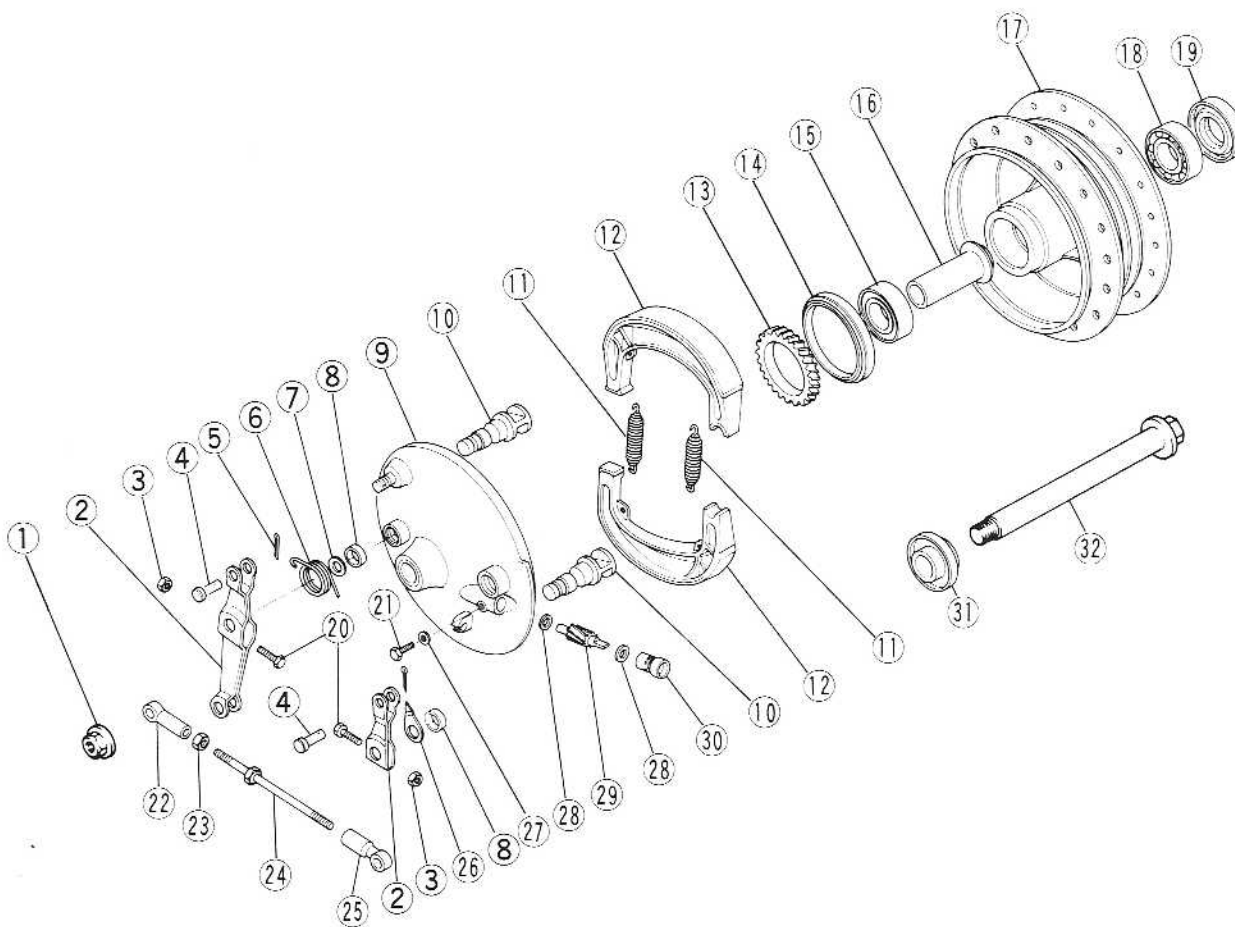

- | | | | |
|------------------|----------------------|---------------------|------------------------|
| 1. Axle Nut | 8. Dust Seal | 15. Ball Bearing | 24. Connecting Rod |
| 2. Cam Lever | 9. Brake Panel | 16. Distance Collar | 25. Joint |
| 3. Nut | 10. Camshaft | 17. Front Hub | 26. Indicator |
| 4. Pin | 11. Shoe Spring | 18. Ball Bearing | 27. Washer |
| 5. Cotter Pin | 12. Brake Shoe | 19. Grease Seal | 28. Washer |
| 6. Return Spring | 13. Speedometer Gear | 20. Bolt | 29. Speedometer Pinion |
| 7. Washer | 14. Grease Seal | 21. Bolt | 30. Bushing |
| | | 22. Joint | 31. Cap |
| | | 23. Locknut | 32. Front Axle |

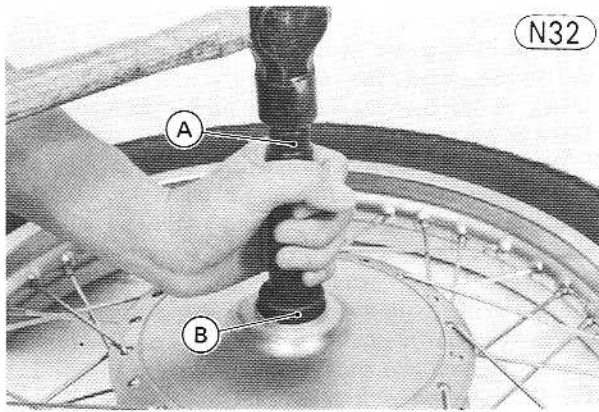

N32

A. Bearing Driver Holder (57001-139)
B. Bearing Driver (57001-288)

- Install a new grease seal on the cap side using a suitable driver. Press the seal so that the face of the seal is level with the surface of the front hub.
- Put the distance collar into the hub.
- Install the brake panel side bearing facing the shield outward. Press the bearing in until it stops at the bottom of the hole using the same special tools used for the other bearing installation.

Front Brake Disassembly:

WARNING Brake linings contain asbestos fiber. Inhalation of asbestos may cause serious scarring of the lungs and may promote other internal injury and illness, including cancer. Observe the following precautions when handling brake linings:

1. Never blow brake lining dust with compressed air.
 2. If any components are to be cleaned, wash with detergent, then immediately discard the cleaning solution and wash your hands.
 3. Do not grind any brake lining material unless a ventilation hood is available and properly used.
- Remove the brake panel (9) from the front hub.
 - Using a clean cloth around the linings to prevent grease or oil from getting on them, remove the brake shoes (12) by pulling them off the brake cam shafts.

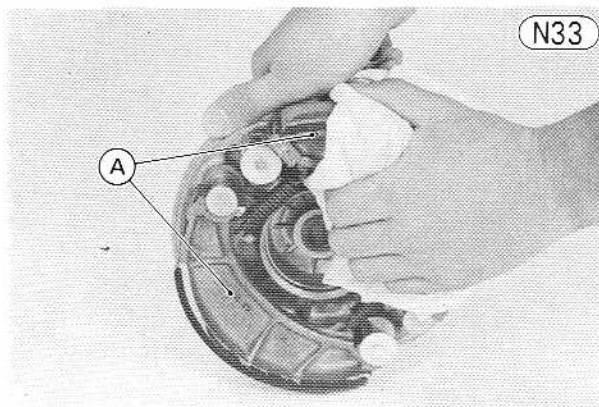

N33

A. Brake Shoes

- Remove the brake springs (11) (2) to separate the two brake shoes.
- Mark the position of each cam lever on the camshaft so that they can later be installed at the same angle.

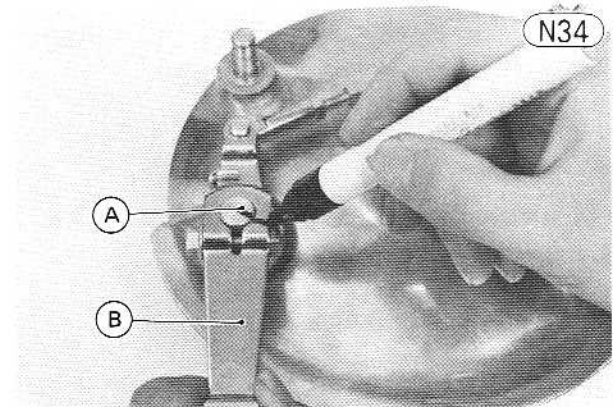

N34

A. Cam Shaft B. Cam Lever

- Remove the nuts (3) and bolts (20), and pull the cam levers off the camshafts.
- Remove the return spring (6), brake lining wear indicator (26), washer (7), and dust seals (8).
- Remove the camshafts (10).

Front Brake Assembly:

- Lubricate the brake parts (Pg. 210).
- Install the brake springs connecting the brake shoes.
- Wrapping a clean cloth around the linings to prevent grease or oil from getting on them, put the shoes back onto the brake panel.
- Fit the dust seals on the camshafts.
- Replace the washer and the brake lining wear indicator. The indicator should point just to the right of the "E" in RANGE.

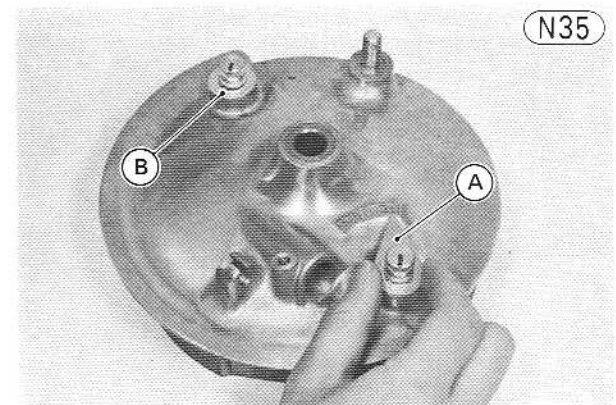

N35

A. Wear Indicator B. Washer

- Install the cam levers with the return spring part of the way onto the camshafts, fit the return spring end into its hole in the panel, and put the cam levers the rest of the way into position on the camshafts. Tighten the bolts.

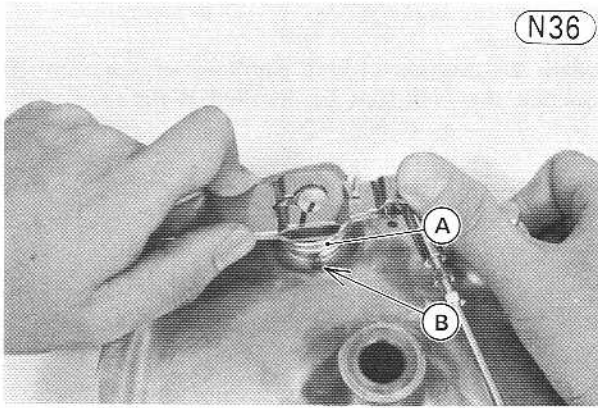

A. Return Spring B. Hole

REAR WHEEL, BRAKE

Removal:

- Raise the rear wheel off the ground.
- Remove the drive chain from the rear sprocket as explained in drive chain removal (Pg 97). The engine sprocket cover does not require removal.
- Remove the clip, nut, lockwasher, and bolt at the rear end of the torque link.

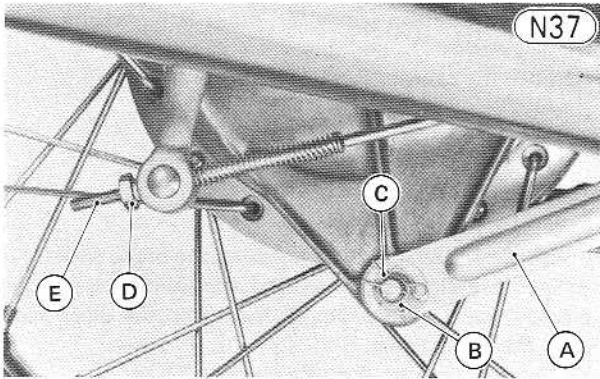

A. Torque Link C. Clip E. Rod
B. Nut D. Adjusting Nut

- Pull off the cotter pin, loosen the axle nut, and unscrew the adjusting nut from the brake rod.

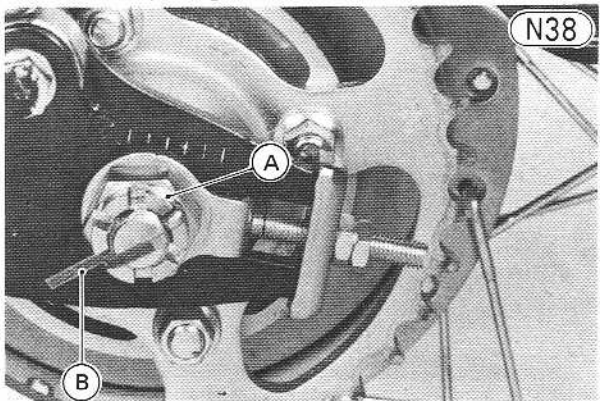

A. Axle Nut B. Cotter Pin

- Pull the rear wheel toward the rear together with the wheel coupling and brake panel with the axle inserted through them.
- Remove the rod joint and spring off the cam lever and rod.

Installation:

- Apply a little grease to the inside surface of the hole in the coupling where the rear hub fits.
- Check to see that the coupling rubber damper ⑩ is fitted in the rear hub.
- Insert the axle from the right side through the right chain adjuster, spacer ⑭, brake panel ⑰, coupling sleeve ⑨, coupling collar ④, and left chain adjuster.
- Install the axle nut on the axle a few turns.
- Slip the rear wheel into the end of the swing arm.
- Fit the drive chain onto the rear sprocket and install the drive chain master link and clip. The direction of the master link clip should be as shown in Fig. G 25 .
- Fit the brake rod joint to the cam lever.
- Install the spring on the end of the brake rod, fit the rod through the joint, and screw on the adjusting nut.
- Insert the torque link bolt into the brake panel, and install the torque link, lockwasher, and nut finger tight.
- Adjust the drive chain (Pg. 24).
- Adjust the rear brake (Pg.189).
- Check the rear brake light switch and adjust if necessary (Pg. 26).

Rear Brake Disassembly:

WARNING Brake linings contain asbestos fiber. Inhalation of asbestos may cause serious scarring of the lungs and may promote other internal injury and illness, including cancer. Observe the following precautions when handling brake linings:

1. Never blow brake linings dust with compressed air.
2. If any components are to be cleaned, wash with detergent, then immediately discard the cleaning solution and wash your hands.
3. Do not grind any brake lining material unless a ventilation hood is available and properly used.

- Remove the brake panel ⑰ from the wheel.
- Using a clean cloth around the linings to prevent grease or oil from getting on them, remove the brake shoes ⑬, by pulling up on the center of the linings.

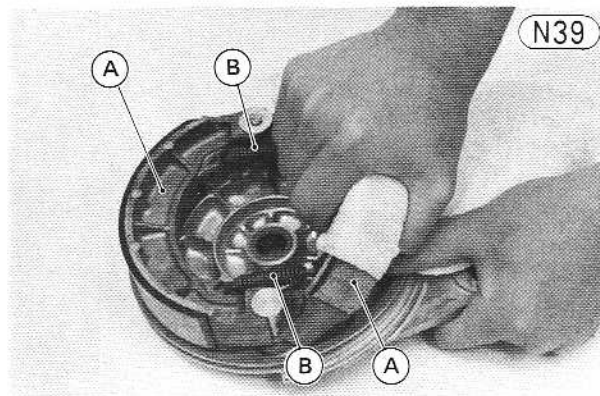

A. Brake Shoe B. Spring

- Remove the springs 15 (2) to separate the two brake shoes.
- Mark the position of the cam lever 27 so that it can be installed later in the same position.
- Unbolt and remove the cam lever, brake lining wear indicator 19, dust seal 18, and camshaft 25.

Rear Brake Assembly:

- Lubricate the brake parts (Pg. 210).
- Put the camshaft back into the panel.
- Fit the springs onto the brake shoes, and wrapping a clean cloth around the linings to prevent grease or oil from getting on them, install the shoes on the brake panel.
- Fit the dust seal and the indicator on the serration so that it points to the extreme right of the USABLE RANGE.

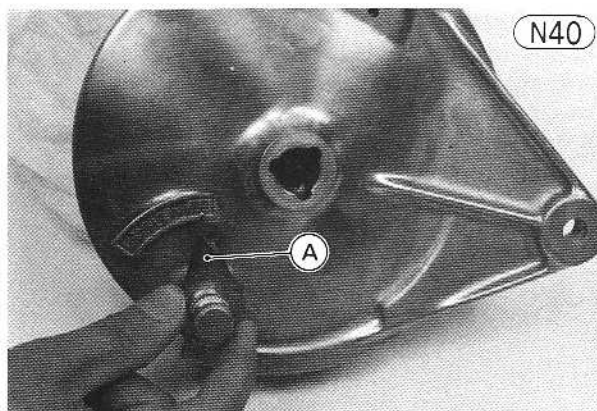

A. Indicator

- Install the cam lever in its original position on the camshaft, and tighten its bolt.

Rear Hub

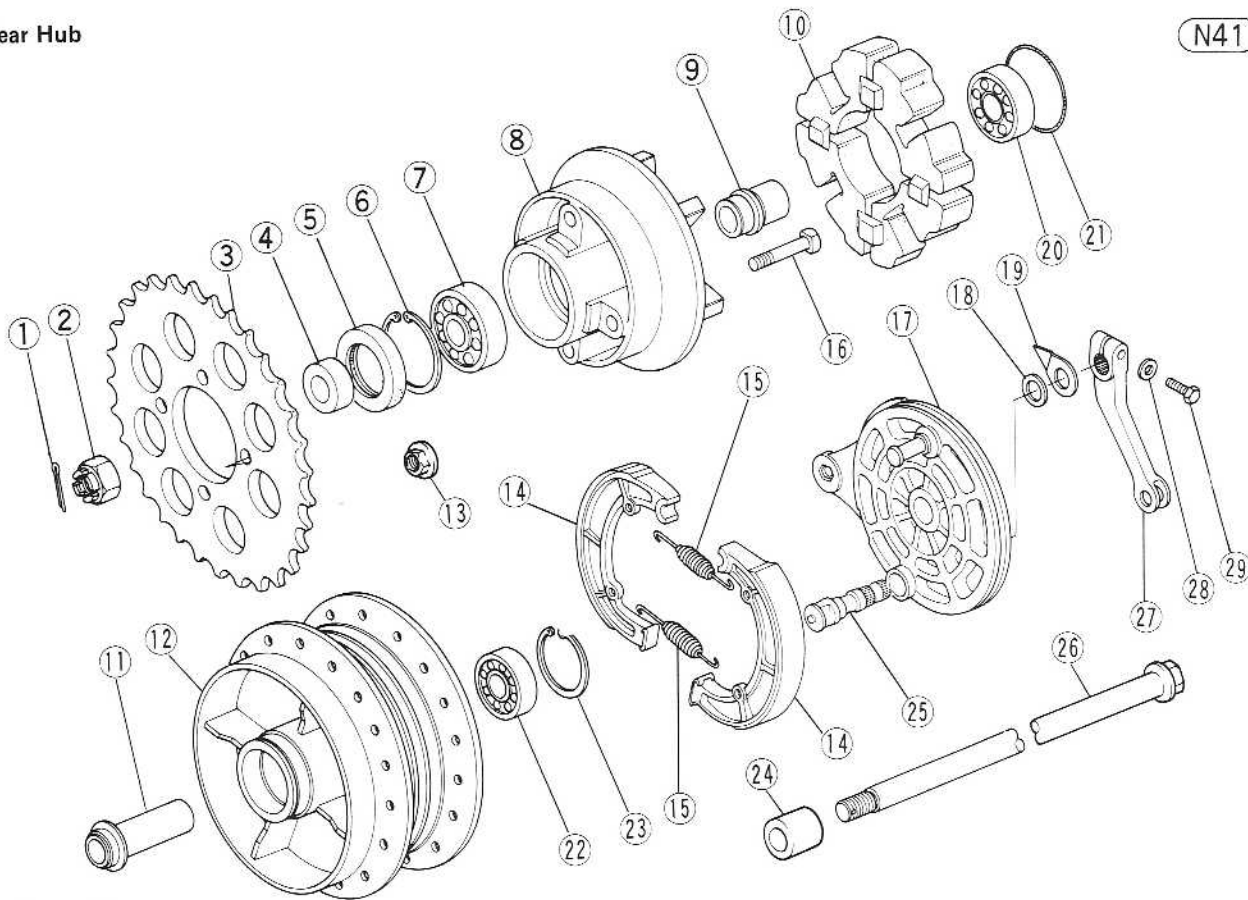

- | | | | |
|------------------|---------------------|----------------------------|--------------------|
| 1. Cotter Pin | 9. Sleeve | 16. Sprocket Mounting Bolt | 23. Circlip |
| 2. Axle Nut | 10. Rubber Damper | 17. Brake Panel | 24. Spacer |
| 3. Rear Sprocket | 11. Distance Collar | 18. Dust Seal | 25. Brake Camshaft |
| 4. Collar | 12. Rear Hub | 19. Indicator | 26. Rear Axle |
| 5. Grease Seal | 13. Nut | 20. Ball Bearing | 27. Cam Lever |
| 6. Circlip | 14. Brake Shoe | 21. O Ring | 28. Washer |
| 7. Ball Bearing | 15. Spring | 22. Ball Bearing | 29. Bolt |

Wheel Coupling Disassembly:

- Remove the rear sprocket nuts 13 (4) to separate the rear sprocket 3 and wheel coupling 8.

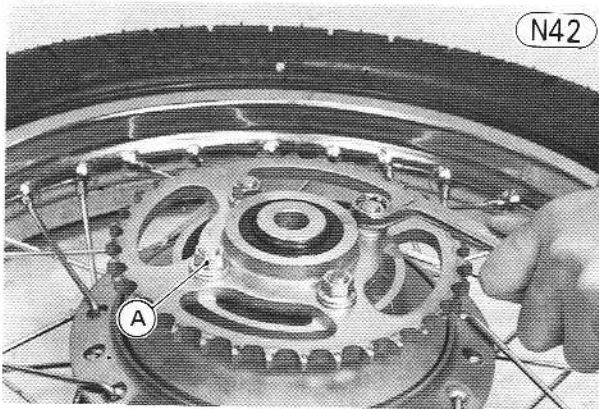

A. Sprocket Nut

- Remove the coupling and rubber damper 10 from the wheel.
- Pull out the coupling collar 4 from the left, and the coupling sleeve 9 from the right.
- Using a hook, pull off the grease seal 5.

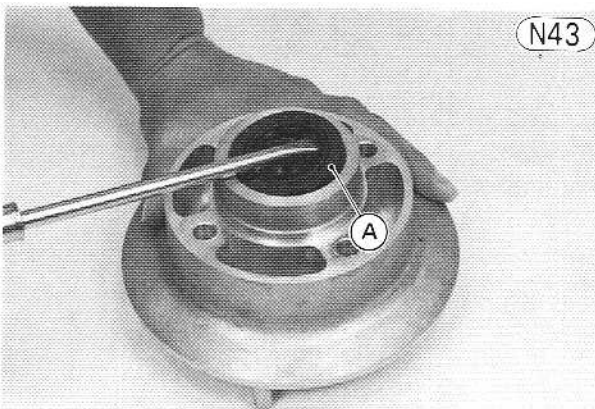

A. Grease Seal

- Remove the circlip 6.
- Remove the bearing 7 by tapping from the wheel side evenly around the bearing inner race.

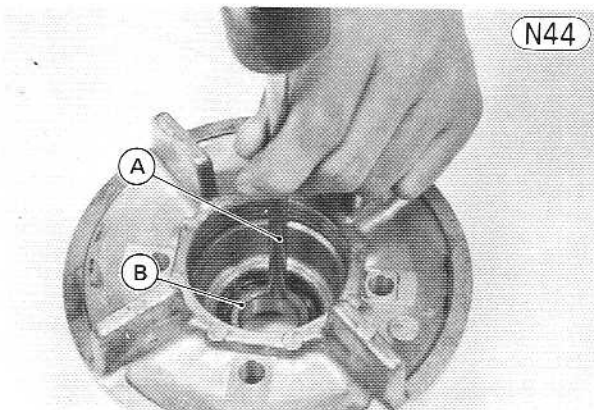

A. Rod B. Bearing Inner Race

Wheel Coupling Assembly:

- Inspect the bearing, and replace if necessary (Pg. 143).
- Lubricate it (Pg. 143), and install it using the bearing driver and the bearing driver holder (special tools). Drive the bearing in until it stops at the bottom of the hole.

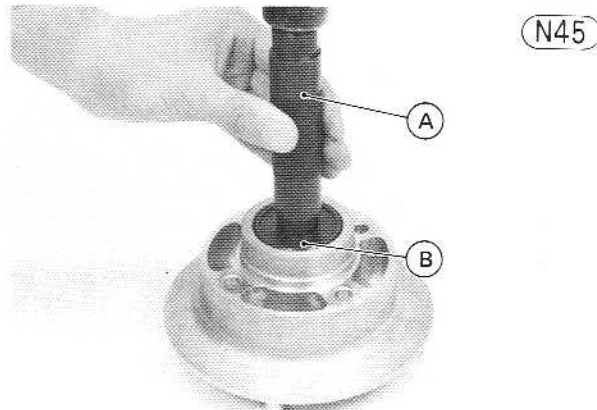

A. Bearing Driver Holder (57001-139)
B. Bearing Driver (57001-289)

- Install the circlip.
- Replace the grease seal with a new one using a suitable driver. Drive in the seal until the face of the seal is level with the end of the grease seal hole.
- Install the rear sprocket, and nuts (4), and install the nuts finger tight.

WARNING The rear sprocket must be installed with the chamfered hole side facing toward the coupling. If not, the sprocket will not seat on the coupling evenly, causing the drive chain to be thrown off by excessive sprocket runout during operation. This can result in rear wheel lockup and loss of control.

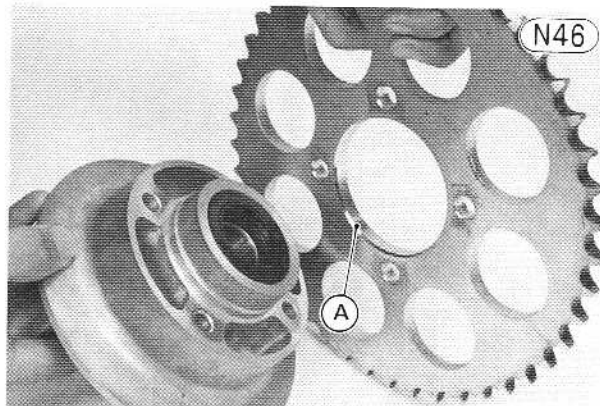

A. Chamfer

- Inspect the O ring 21 on the rear hub, replace it with a new one if it has deteriorated and apply a little grease to the O ring.
- Install the coupling sleeve on the right side and the coupling collar on the left side of the coupling.
- Install the rubber damper and wheel coupling on the rear hub, and then tighten the sprocket nuts to 3.0 kg-m (22 ft-lbs) of torque.

Rear Hub Disassembly:

- Remove the wheel coupling ⑧, rear brake panel ⑰, and rubber damper ⑩ from the wheel.
- Remove the circlip ⑳.
- Insert a metal rod into the hub from the brake panel side, and remove the left side bearing ㉑ by tapping evenly around the bearing inner race. The distance collar ㉒ will come out with the bearing.

Bearing Removal

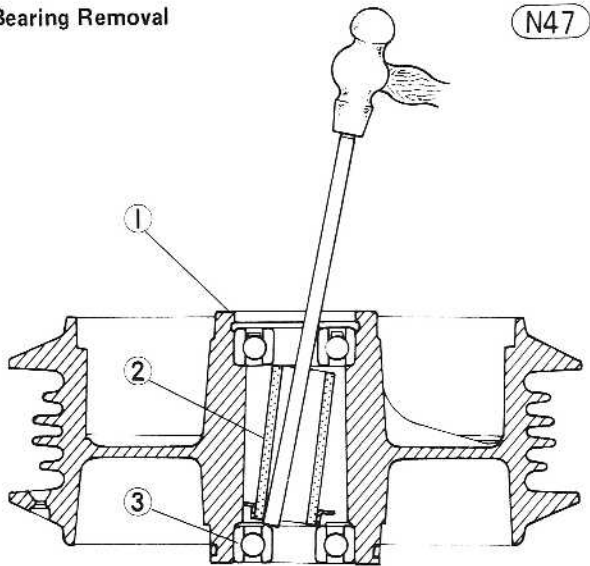

1. Rear Hub
2. Distance Collar
3. Ball Bearing

- Insert the metal rod into the hub from the other side, and tap out the remaining bearing ㉑.

Rear Hub Assembly:

- Inspect the bearings and replace them if necessary (Pg. 143).
- Lubricate the ball bearings (Pg.143).
- Before installing the wheel bearings, blow any dirt or foreign particles out of the hub with compressed air to prevent contamination of the bearings.
- Install the coupling side ball bearing using the wheel bearing driver and the bearing driver holder (special tools). Press the bearing in until it stops at the bottom of the hole.

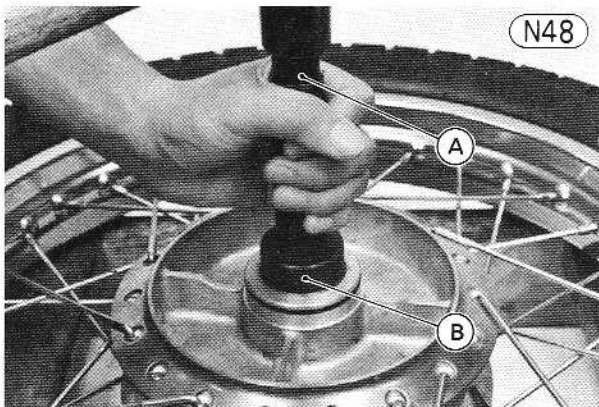

A. Bearing Driver Holder (57001-139)
B. Bearing Driver (57001-290)

- Put the distance collar into the hub.
- Install the brake panel side bearing facing the shield outward. Press the bearing in until it stops at the bottom of the hole using the bearing driver (special tool : P/N 57001-288) and bearing driver holder.
- Install the circlip.
- Inspect the O ring ㉒ on the rear hub and replace it if necessary. Apply a little grease to the O ring before fitting the coupling on the rear hub.

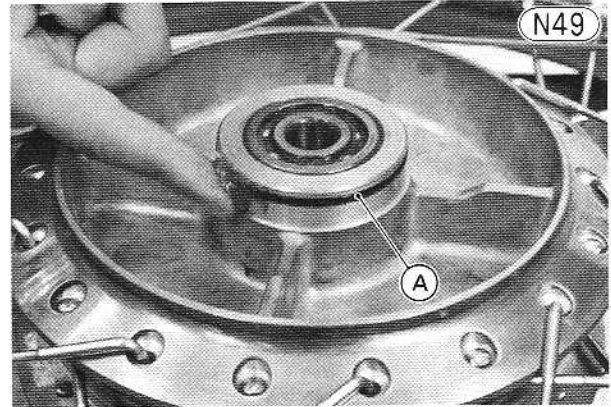

A. "O" Ring

RIM (Z250-B)

Removal:

- Remove the wheel from the motorcycle (Pg. 198 or 202).
- Remove the rubber band.
- Take the tire and tube off the rim.
- Tape or wire all the spoke intersections so that the spokes don't get mixed up, and unscrew the nipples from all the spokes with a screwdriver.

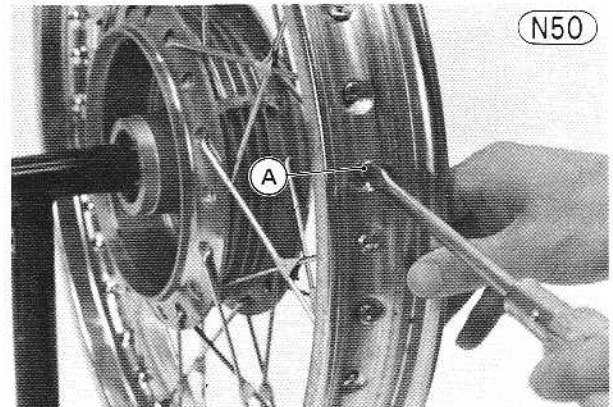

A. Nipple

Installation:

- Fit all the spokes through the holes, and screw all the nipples onto the spokes tightening them partially.
- Suspend the wheel by the axle, and set up a dial gauge to measure rim runout. Fix the axle in place if necessary to prevent horizontal movement.

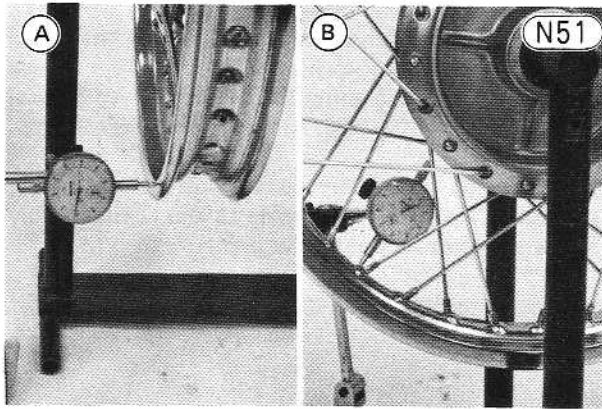

A. Axial Runout Measurement
B. Radial Runout Measurement

- Tighten the spokes evenly so that the radial (out from the axle) runout is less than 0.8 mm and the axial (side to side) runout is less than 0.5 mm.
- Make sure that the spokes are tightened evenly. Standard torque is 0.3 kg-m (26 in-lbs).
- Mount the tube and tire (Pg. 124).
- Balance the wheel (Pg. 29).
- Mount the wheel on the motorcycle (Pg. 198 or 202).
- Adjust the drive chain (Pg. 24) and rear brake (Pg. 193), if the rear wheel was removed.
- Adjust the front brake (Pg. 192).

SPOKE

Breakage Replacement:

- Reduce the tire air pressure by a small amount.
- Insert the new spoke through the hub, and bend it to meet the nipple.

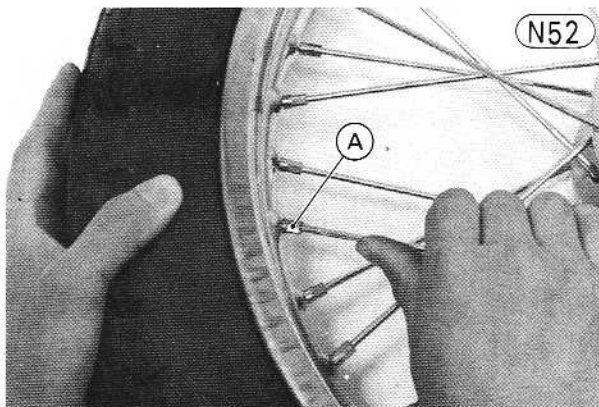

A. Nipple

- Tighten with a spoke wrench. Standard torque is 0.3 kg-m (26 in-lbs).
- Inflate the tire to standard pressure (Pg. 140).

Maintenance

ROCKER ARMS, SHAFTS

The procedures are the same as those for the 1979 Z250-A1 with the following exception. Refer to Pg. 119.

Rocker arm/shaft wear

Table N5 Rocker Shaft Diameter

| | |
|---------------|----------|
| Service Limit | 12.94 mm |
|---------------|----------|

CAMSHAFT

The procedures are the same as those for the 1979 Z250-A1 with the following exception. Refer to Pgs. 119~121.

Journal wear

Table N6 Camshaft Journal/Cylinder Head Cover Clearance

| | |
|---------------|---------|
| Service Limit | 0.20 mm |
|---------------|---------|

CYLINDER BLOCK, PISTONS

The procedures are the same as those for the 1979 Z250-A1 with the following exception. Refer to Pgs. 127 ~ 130.

Piston ring, piston ring groove wear

Table N7 Piston Ring Thickness

| | | |
|---------------|----------|----------|
| | Top Ring | 2nd Ring |
| Service Limit | 1.1 mm | 1.1 mm |

Table N8 Piston Ring Groove Width

| | | |
|---------------|----------|----------|
| | Top Ring | 2nd Ring |
| Service Limit | 1.3 mm | 1.3 mm |

Table N9 Rim, Spoke Size

| | | | |
|-------|------------------------|-----------------------|-----------|
| | Spoke | | Rim |
| | Inner | Outer | |
| Front | #9 x 147.5 x 103° | #9 x 147.0 x 86° | 1.60 x 18 |
| Rear | #8 x #9 x 155.5 x 102° | #8 x #9 x 154.5 x 84° | 1.85 x 18 |

WHEELS

The procedures are the same as those for the 1979 Z250-A1 with the following exceptions. Refer to Pgs. 140 ~ 143.

Rim, Spokes

The rim of each wheel is made of steel and is connected to the hub by the spokes. A rim band around the outside center of the rim keeps the tube from coming into direct contact with the spoke nipples.

Since the spokes must withstand repeated stress, it is important to take sufficient care that the spokes are not allowed to loosen and that they are tightened evenly. Loose or unevenly tightened spokes cause the rim to warp, increase the possibility of spoke breakage, and hasten nipple and spoke metal fatigue.

NOTE: The rim size shown in Table N9 is the outer width and diameter, both in inches. The spoke size is diameter number by length in millimeters. The two numbers for diameter size mean that each spoke has two diameters. To make the spoke more resistant to breakage the diameter is greater near the hub.

Spoke breakage

If any spoke breaks, it should be replaced immediately. A missing spoke places an additional load on the other spokes, which will eventually cause other spokes to break.

Periodically check that all the spokes are tightened evenly since they stretch a certain amount during use. Standard spoke tightening torque is 0.30 kg-m (26 ft-lbs). Over- or under-tightening may cause breakage.

Rim runout

Set a dial gauge against the side of the rim, and rotate the wheel to measure axial runout. The difference between the highest and lowest dial readings is the amount of runout.

Set the dial gauge against the inner circumference of the rim, and rotate the wheel to measure radial runout. The difference between the highest and lowest dial readings is the amount of runout.

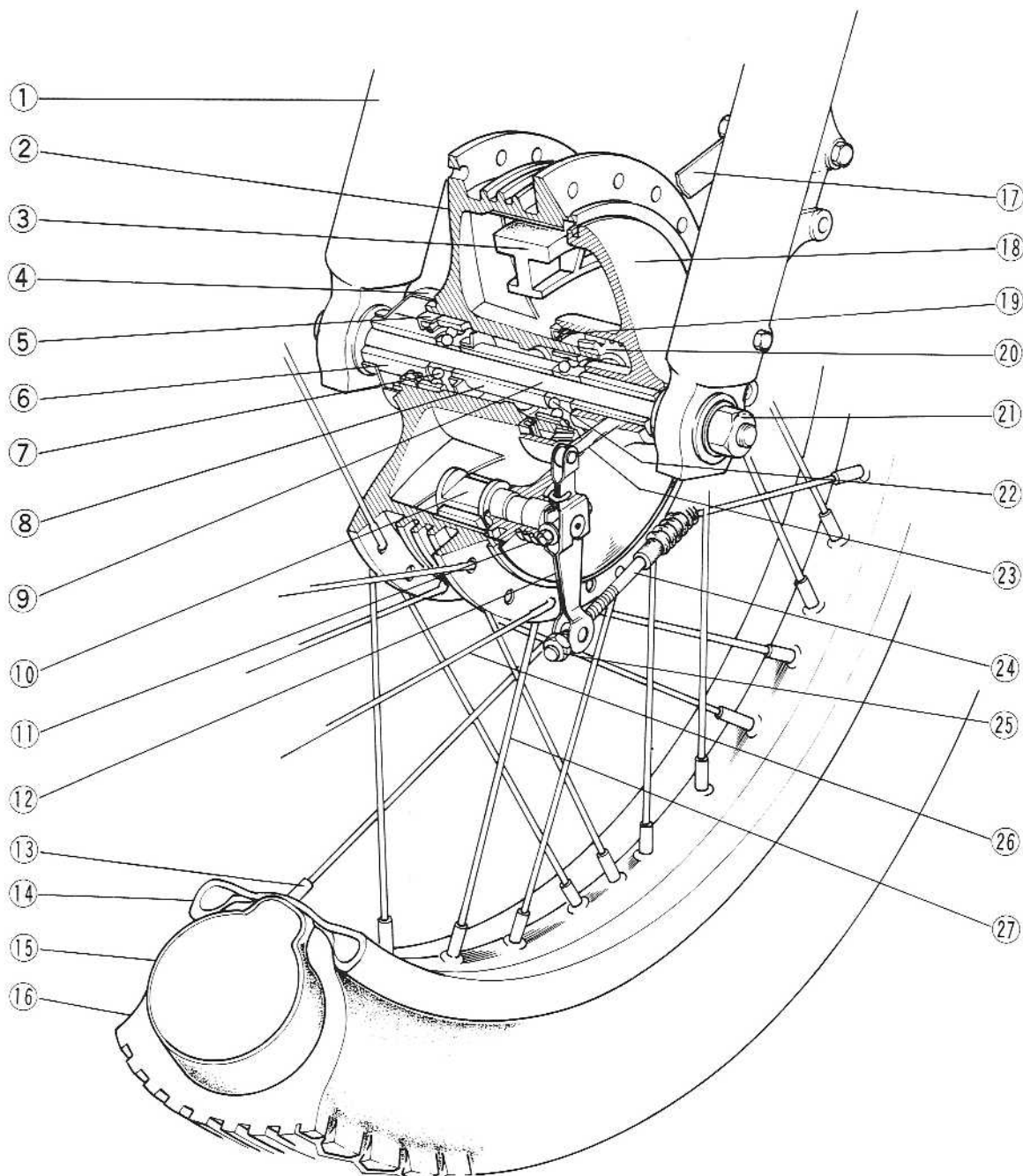

- 1. Front Fork Leg
- 2. Front Hub
- 3. Brake Shoe
- 4. Cap
- 5. Grease Seal
- 6. Collar
- 7. Ball Bearing

- 8. Distance Collar
- 9. Front Axle
- 10. Brake Camshaft
- 11. Return Spring
- 12. Cam Lever
- 13. Spoke Nipple
- 14. Rim

- 15. Tube
- 16. Tire
- 17. Torque Link
- 18. Brake Panel
- 19. Grease Seal
- 20. Speedometer Gear
- 21. Front Axle Nut

- 22. Ball Bearing
- 23. Connecting Rod
- 24. Brake Cable
- 25. Adjusting Nut
- 26. Outer Spoke
- 27. Inner Spoke

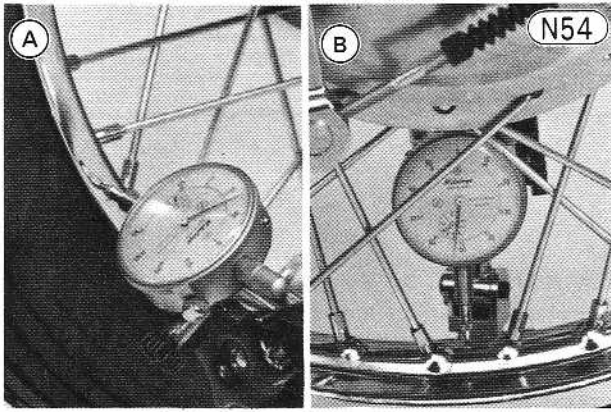

A. Axial Runout Measurement
B. Radial Runout Measurement

Table N10 Rim Runout

| | Axial | Radial |
|---------------|-------|--------|
| Service Limit | 2 mm | 2 mm |

A certain amount of rim warp (runout) can be corrected by recentering the rim. Loosen some spokes and tighten others to change the position of different parts of the rim. If the rim is badly bent, however, it should be replaced.

Wheel Bearings, Grease Seals

Clean and grease the speedometer gear in the front hub in accordance with the Periodic Maintenance Chart (Pg. 191).

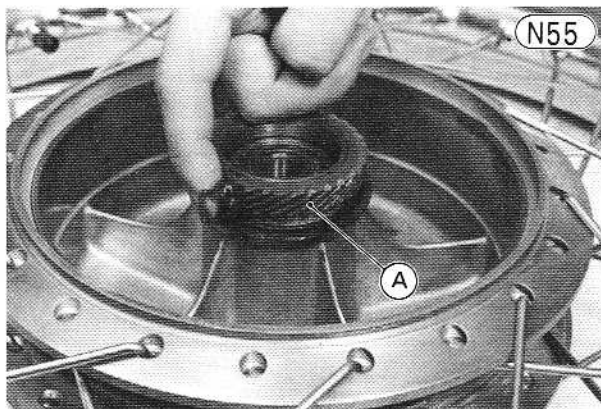

A. Speedometer Gear

Table N11 Wheel Bearings, Grease Seals

| | Front Wheel | | Rear Wheel | | |
|-------------|-------------|-----------|------------|----------|-----------|
| | Hub Left | Hub Right | Coupling | Hub Left | Hub Right |
| Bearing | #6302Z | #6302 | #6205 | #6303 | #6302NS |
| Grease Seal | WOC55687 | WTC25428 | PJN355207 | | |

BRAKES

WARNING Brake linings contain asbestos fiber. Inhalation of asbestos may cause serious scarring of the lungs and may promote other internal injury and illness, including cancer. Observe the following precautions when handling brake linings:

1. Never blow brake linings dust with compressed air.
2. If any components are to be cleaned, wash with detergent, then immediately discard the cleaning solution and wash your hands.
3. Do not grind any brake lining material unless a ventilation hood is available and properly used.

Brake drum wear

Measure the inside diameter of the brake drum with calipers to determine wear. Since uneven drum wear will decrease braking effectiveness, take measurement at a minimum of two places. If the drum is worn unevenly or if it is scored, turn the drum down on a brake drum lathe or replace the hub with a new one. (Do not turn it down to the service limit, and do not turn it down if any diameter measurement exceeds the service limit). If any diameter measurement exceeds the service limit, replace the hub with a new one.

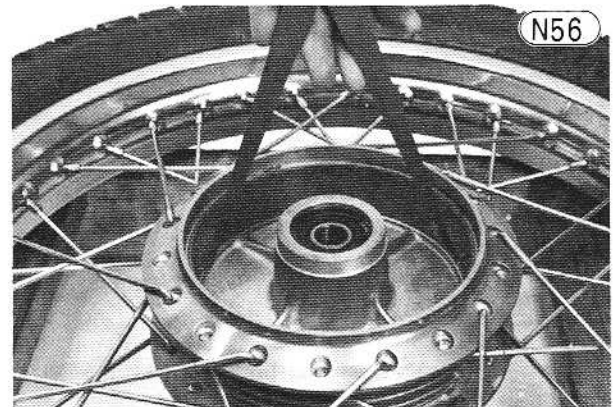

Table N12 Brake Drum Inside Diameter

| | Front | Rear |
|---------------|-----------|-----------|
| Service Limit | 180.75 mm | 160.75 mm |

Brake shoe lining wear

Check the thickness of the brake linings, and replace both shoes as a set if the thickness at any point is less than the service limit. If the thickness of the brake linings is sufficient, check the linings for uneven wear, and file or sand down any high spots. With a wire brush, remove any foreign particles imbedded in the lining surface. Wash off any oil or grease with a high flash-point solvent. Do not use one which will leave an oily residue. In case the linings are damaged or the surface cannot be restored by sanding and cleaning, the shoes must be replaced.

Table N13 Brake Lining Thickness

| | Front Wheel | Rear Wheel |
|---------------|-------------|------------|
| Service Limit | 2.5 mm | 2 mm |

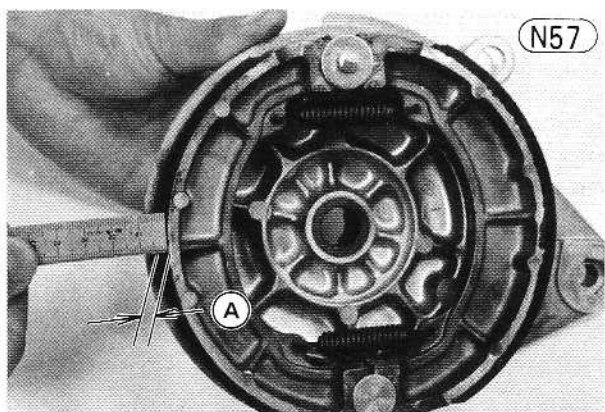

A. Lining Thickness

Brake shoe spring tension

If the brake springs have stretched, they will not pull the shoes back away from the drum after the brake pedal or lever is released, and the shoes will drag on the drum. Remove the springs, and check their free length with vernier calipers. If either is stretched beyond the service limit, replace both springs.

Brake Spring Free Length

(N58)

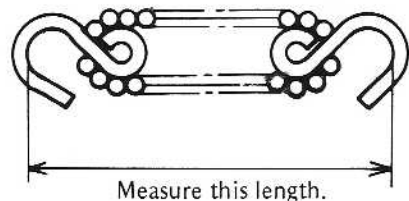

Table N14 Brake Spring Free Length

| | Front Wheel | Rear Wheel |
|---------------|-------------|------------|
| Service Limit | 48.5 mm | 50 mm |

Camshaft, shaft hole wear

Excessive shaft to hole clearance will increase camshaft play and reduce braking efficiency.

Measure the shaft diameter with a micrometer, and replace it if it is worn down to less than the service limit.

Measure the inside diameter of the camshaft hole, and replace the brake panel if the hole is worn past the service limit.

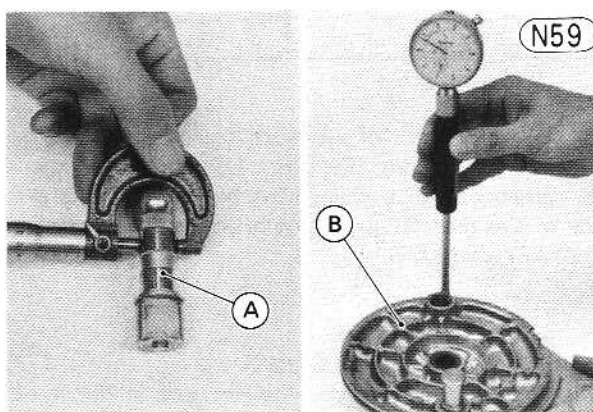

A. Camshaft

B. Brake Panel

Table N15 Brake Camshaft Diameter

| | Front Wheel | Rear Wheel |
|---------------|-------------|------------|
| Service Limit | 14.83 mm | 16.83 mm |

Table N16 Camshaft Hole Diameter

| | Front Wheel | Rear Wheel |
|---------------|-------------|------------|
| Service Limit | 15.18 mm | 17.18 mm |

Lubrication

Every time that the brake is disassembled, and in accordance with the Periodic Maintenance Chart (Pg. 191), wipe out the old grease, and re-grease the brake pivot points. Apply grease to the brake shoe anchor pin, spring ends, and cam surface of the camshaft, and fill the camshaft groove with grease. Do not get any grease on the brake shoe linings, and wipe off any excess grease so that it will not get on the linings or drum after brake assembly.

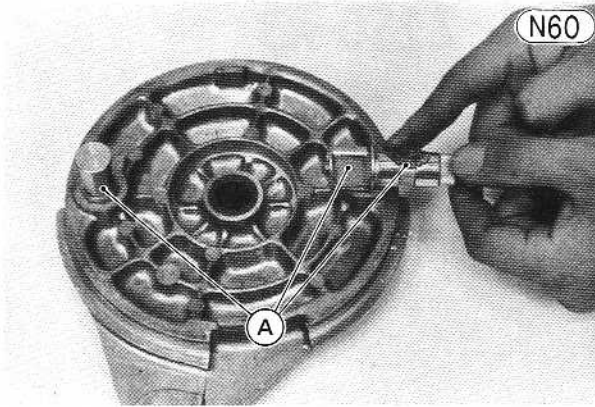

A. Grease

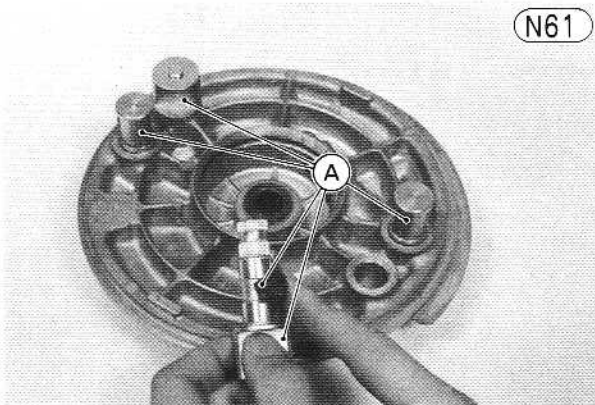

A. Grease

Appendix

SPECIAL TOOLS

Add the wheel bearing driver (special tool: P/N 57001-288) to the special tool list (Pg. 175 ~ 178) and eliminate the bearing driver (P/N 57001-284) from the list.

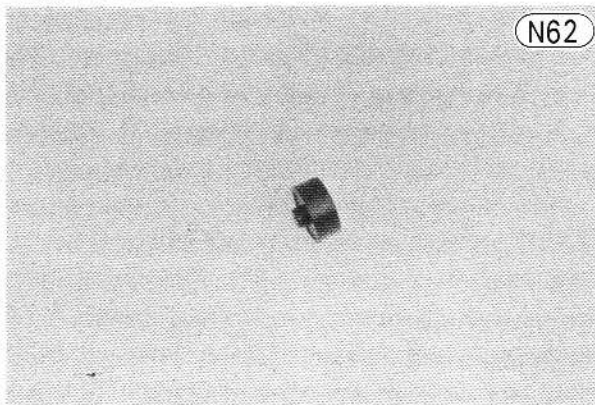

A. Bearing Driver (57001-288)

WIRING DIAGRAM

The wiring diagram for the Z250-B is the same as that for the Z250-A. See Pg. 179.

Supplement for 1981 Z250-A3

Table of Contents

| | |
|---|-----|
| MODEL IDENTIFICATION | 213 |
| SPECIFICATIONS | |
| SPECIFICATIONS | 214 |
| PERIODIC MAINTENANCE CHART | 216 |
| ADJUSTMENT | |
| IGNITION TIMING | 217 |
| CAMSHAFT CHAIN | 217 |
| THROTTLE CABLE | 217 |
| REAR SHOCK ABSORBER | 217 |
| LUBRICATION | 218 |
| DISASSEMBLY | |
| TORQUE AND LOCKING AGENT | 218 |
| CABURETORS | 218 |
| CAMSHAFT CHAIN TENSIONER | 223 |
| CYLINDER BLOCK | 224 |
| PISTON, PISTON RINGS | 224 |
| ENGINE SPROCKET | 225 |
| TRANSMISSION | 225 |
| FRONT WHEEL | 225 |
| FRONT BRAKE | 227 |
| MAINTENANCE | |
| CABURETORS | 230 |
| CAMSHAFT CHAIN, GUIDES, TENSIONER | 230 |
| CYLINDER HEAD, VALVES | 230 |
| TRANSMISSION | 232 |
| SWING ARM | 232 |
| IGNITION SYSTEM | 232 |
| APPENDIX | |
| SPECIAL TOOLS | 233 |

Model Identification

Z250-A3 Left Side View

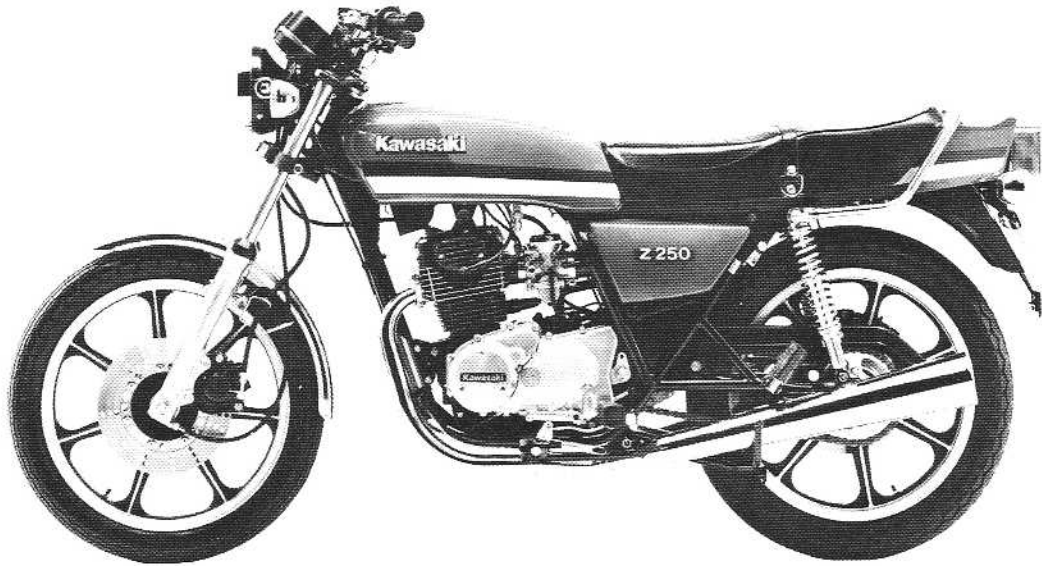

Z250-A3 Right Side View

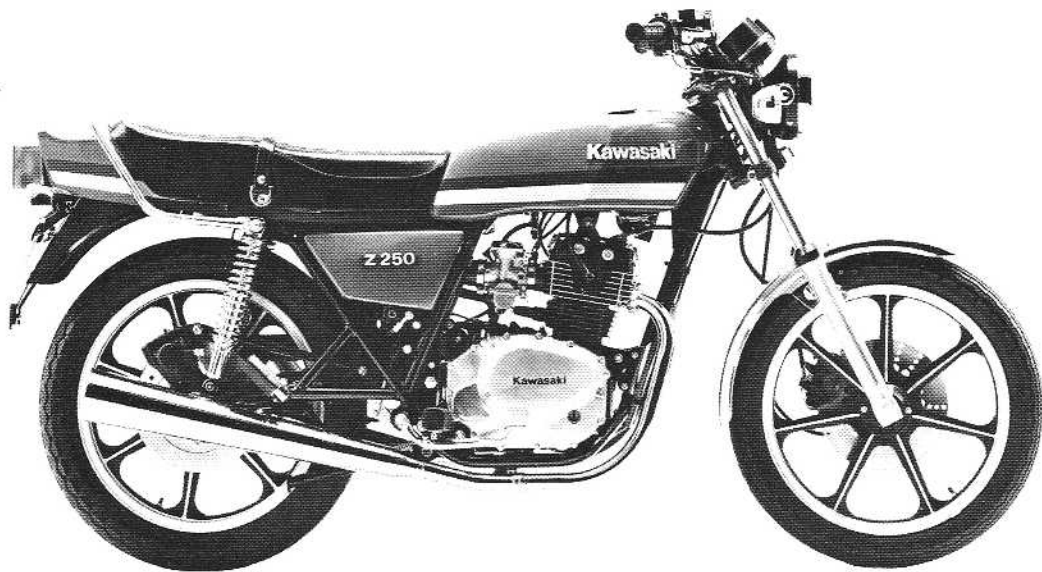

Specifications

SPECIFICATIONS

| | Z250-A3 | Z250-B2 | | |
|------------------------|--|--------------------------------|----------|---|
| Dimensions | | | | |
| Overall length | 2,020 mm, (UK) 2,015 mm, (E) (A) 2,060 mm | (UK) 2,020 mm, (A) 2,060 mm | | |
| Overall width | 760 mm, (E) 740 mm | 705 mm | | |
| Overall height | 1,085 mm, (E) 1,070 mm | 1,050 mm | | |
| Wheelbase | 1,340 mm | * | | |
| Road clearance | 145 mm, (E) 140 mm | 155 mm | | |
| Dry weight | 153 kg | 147 kg | | |
| Fuel tank capacity | 13.6 ℓ | * | | |
| Performance | | | | |
| Climbing ability | 25° | * | | |
| Braking distance | 12 m from 50 kph | 14 m from 50 kph | | |
| Minimum turning radius | 2.2 m | * | | |
| Engine | | | | |
| Type | SOHC, 2-cylinder, 4-stroke, air cooled | * | | |
| Bore and stroke | 55.0 x 52.4 mm | * | | |
| Displacement | 248 cc | * | | |
| Compression ratio | 9.5 | * | | |
| Maximum horsepower | 27 HP @10,000 rpm (G) 26.7 HP @10,000 rpm | * | | |
| Maximum torque | 2.1 kg-m @8,000 rpm (G) 2.02 kg-m @8,000 rpm | * | | |
| Valve timing | Inlet | Open | 21° BTDC | * |
| | | Close | 59° ABDC | * |
| | | Duration | 260° | * |
| | Exhaust | Open | 61° BBDC | * |
| | | Close | 19° ATDC | * |
| | | Duration | 260° | * |
| Carburetors | Keihin CV32 x 2 | * | | |
| Lubrication system | Forced lubrication (wet sump) | * | | |
| Engine oil | SE class SAE 10W40, 10W50, 20W40, or 20W50 | * | | |
| Engine oil capacity | 1.8 ℓ, 1.5 ℓ (without filter change) | * | | |
| Starting system | Electric starter | * | | |
| Ignition system | Battery and coil | * | | |
| Ignition timing | From 10° BTDC @1,250 rpm to 40° BTDC @2,500 rpm | * | | |
| Spark plug | NGK D8EA or ND X24ES-U (E) NGK DR8ES or ND X24ESR-U | * | | |
| Transmission | | | | |
| Type | 6-speed, constant mesh, return shift | * | | |
| Clutch | Wet, multi disc | * | | |
| Gear ratio: | 1st | 2.60 (39/15) | * | |
| | 2nd | 1.79 (34/19) | * | |
| | 3rd | 1.41 (31/22) | * | |
| | 4th | 1.16 (29/25) | * | |
| | 5th | 1.00 (27/27) | * | |
| | 6th | 0.89 (25/28) | * | |

| | | Z250-A3 | Z250-B2 |
|-------------------------------------|-------|----------------------------|---|
| Primary reduction ratio | | 3.74 (71/19) | * |
| Final reduction ratio | | 2.33 (35/15), Chain drive | * |
| Overall drive ratio | | 7.79 (@Top gear) | * |
| Electrical Equipment | | | |
| Alternator Rated Output | | 13.5 amp. @8,000 rpm, 14V | * |
| Regulator/Rectifier | | Shindengen SH221-12 | * |
| Ignition coil | | Toyo denso ZC003-12V | * |
| Battery | | Yuasa YB10L-A2(12V 10AH) | * |
| Starter | | Mitsuba SM-725-1 | * |
| Headlight type | | Semi-sealed | * |
| Headlight | | 12V 50/40W | * |
| | | Ⓔ 12V 35/35W, Ⓕ 12V 36/36W | |
| Tail/Brake light | | 12V 8/27W, Ⓔ Ⓐ 12V 5/21W | * |
| City light | | 12V3W, Ⓔ 12V 4W | * |
| Turn signal lights | | 12V 23W, Ⓔ 12V 21W | * |
| Meter lights | | 12V 3.4W | * |
| Indicator lights | | 12V 3.4W | * |
| Horn(s) | | 12V 2A, Ⓘ 12V 2.5A x 2 | * |
| Frame | | | |
| Type | | Tubular, single cradle | * |
| Steering angle | | 40° to either side | * |
| Castor | | 27° | * |
| Trail | | 100 mm | * |
| Tire size | Front | 3.00S-18 4PR | * |
| | Rear | 3.50S-18 4PR | * |
| Suspension | Front | Telescopic fork | * |
| | Rear | Swing arm | * |
| Wheel travel | Front | 150 mm | * |
| | Rear | 98 mm | * |
| Front fork oil capacity (each fork) | | 150 cc | * |
| Front fork oil type | | SAE 5W20 | * |
| Brakes | | | |
| Type | Front | Single disc brake | Internal expansion, two-leading |
| | Rear | Single disc brake | Internal expansion, leading-trailing |
| Effective disc diameter | Front | 226 mm | — |
| | Rear | 218 mm | — |
| Inside diameter and width | Front | — | 180 x 30 mm |
| | Rear | — | 160 x 30 mm |

Ⓐ : Australian model, Ⓔ : European model, ⒺⒾ : European model except Italian model
 Ⓕ : French model, Ⓘ : Italian model, ⒶⒶ : U.K. model ⒶⒶ : West German model
 Specification subject to change without notice, and may not apply to every country.

PERIODIC MAINTENANCE CHART (Z250-A3)

The maintenance and adjustments must be done in accordance with this chart to keep the motorcycle in good running condition. The initial maintenance is vitally important and must not be neglected.

| OPERATION | FREQUENCY | Whichever comes first ↓ | ODOMETER READING* | | | | | | | See Page |
|---|--------------|----------------------------|-------------------|----------|-----------|-----------|-----------|-----------|-----------|----------|
| | | | 800 km | 5,000 km | 10,000 km | 15,000 km | 20,000 km | 25,000 km | 30,000 km | |
| Battery electrolyte level – check † | month | ↓ | • | • | • | • | • | • | • | 156 |
| Brake – check † | | | • | • | • | • | • | • | • | 25 |
| Brake light switch – check † | | | • | • | • | • | • | • | • | 26 |
| Brake wear – check † | | | | • | • | • | • | • | • | 145 |
| Brake fluid level – check † | month | | • | • | • | • | • | • | • | 145 |
| Brake fluid – change | year | | | | • | | • | | • | 145 |
| Clutch – adjust | | | • | • | • | • | • | • | • | 20 |
| Carburetor operation – check † | | | • | • | • | • | • | • | • | 18 |
| Throttle grip – check † | | | • | • | • | • | • | • | • | 217 |
| Steering play – check † | | | • | • | • | • | • | • | • | 26 |
| Drive chain wear – check † | | | | • | • | • | • | • | • | 144 |
| Front fork-clean | | | | • | • | • | • | • | • | 151 |
| Nuts, Bolts, Fasteners – check † | | | • | | • | | • | | • | 218 |
| Spark plug – clean and gap † | | | • | • | • | • | • | • | • | 12 |
| Ignition timing – check † | | | • | • | • | • | • | • | • | 217 |
| Valve clearance – check † | | | • | • | • | • | • | • | • | 16 |
| Air cleaner element – clean | | | | • | | • | | • | | 115 |
| Air cleaner element – replace | 5 cleanings | | | | • | | • | | • | 115 |
| Fuel system – clean | | | | | • | | • | | • | 22 |
| Tire tread wear – check † | | | | • | • | • | • | • | • | 140 |
| Engine oil – change | year | | • | • | • | • | • | • | • | 22 |
| Oil filter – replace | | | • | | • | | • | | • | 22 |
| General lubrication – perform | | | | • | • | • | • | • | • | 29 |
| Front fork oil – change | | | | | • | | • | | • | 152 |
| Timing advancer – lubricate | | | | | • | | • | | • | 162 |
| Swing arm – lubricate | | | | | • | | • | | • | 218 |
| Wheel bearing – lubricate | 2 years | | | | | | • | | | 143 |
| Speedometer gear – lubricate | 2 years | | | | | | • | | | 89 |
| Steering stem bearing – lubricate | 2 years | | | | | | • | | | 150 |
| Master cylinder cup and dust seal – replace | 2 years | | | | | | | | | 147 |
| Caliper piston seal and dust seal – replace | 2 years | | | | | | | | | 148 |
| Brake hose – replace | 4 years | | | | | | | | | 150 |
| Fuel hose – replace | 4 years | | | | | | | | | — |
| Drive chain – lubricate | Every 300 km | | | | | | | | | 144 |
| Drive chain slack – check † | Every 800 km | | | | | | | | | 24 |

* For higher odometer readings, repeat at the frequency interval established here.

† Replace, add, adjust or torque if necessary.

Adjustment

IGNITION TIMING

The adjustment procedures are the same as those for the 1979 Z250-A1 with the following exception. Refer to Pgs. 12-16.

Table N17 Timing Advancing

| | Engine Speed (rpm) |
|----------------|--------------------|
| Advance Begins | 1,400 – 1,600 |
| Full Advance | 2,400 – 2,600 |

CAMSHAFT CHAIN

The camshaft chain tensioner on this motorcycle is an automatic type. Since the camshaft chain slack (developed by chain and chain guide wear) is taken up by this automatic camshaft chain tensioner, the chain requires no periodic maintenance.

THROTTLE CABLE

There is a throttle cable to open the butterfly valves in the carburetors. If the cable is too loose due either to cable stretch or maladjustment, the excessive play in the throttle grip will cause a delay in throttle response, which will be especially noticeable at low rpm. Also, the butterfly valves may not open fully at full throttle. On the other hand, if the cable is too tight, the throttle will be hard to control, and the idle speed will be erratic.

To check the throttle cable adjustment:

- Check that there is 2~3 mm throttle grip play when lightly turning the throttle grip back and forth.

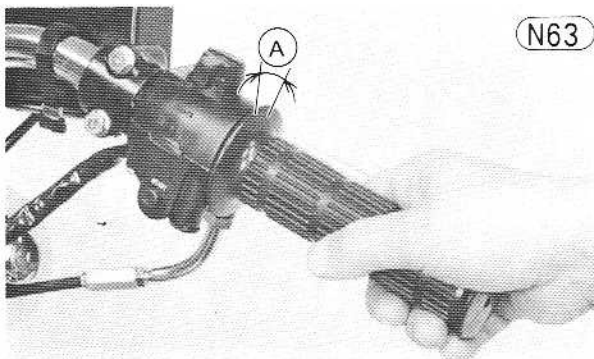

A. 2~3 mm

To adjust the throttle cable:

- If the cable has improper play, adjust it as follows:
- Loosen the locknut at the throttle grip, and turn the adjusting nut until the proper amount of throttle grip play is obtained. Tighten the locknut.

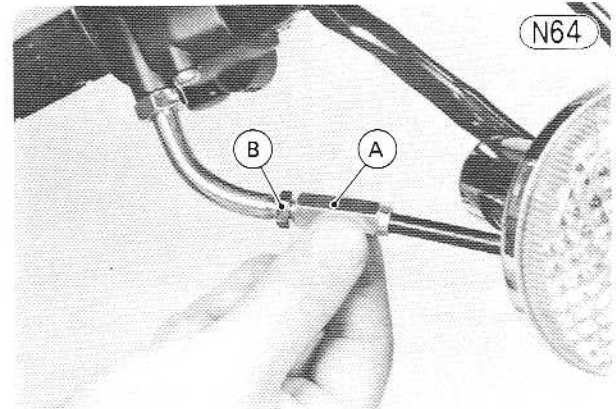

A. Adjusting Nut B. Locknut

NOTE: If the throttle cable cannot be adjusted by using the cable adjusting nut at the upper end of the throttle cable, use the cable adjuster at the lower end of the throttle cable (at the carburetor). Do not forget to securely tighten the adjuster locknut.

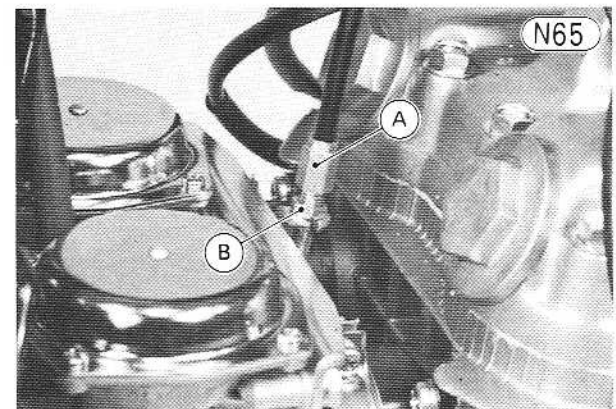

A. Adjuster B. Locknut

REAR SHOCK ABSORBERS

The rear shock absorbers can be adjusted to one of five positions to suit riding conditions. They can be left soft for average riding but should be adjusted harder for high speed riding, riding on rough roads, or riding with a passenger. Shock absorbers adjusted either too soft or too hard adversely affect riding comfort and stability.

To adjust the rear shock absorbers:

- Turn the adjusting sleeve on each shock absorber to the desired position with a screwdriver bit. The higher the adjusting sleeve is positioned, the stronger the spring tension, and the harder the ride.

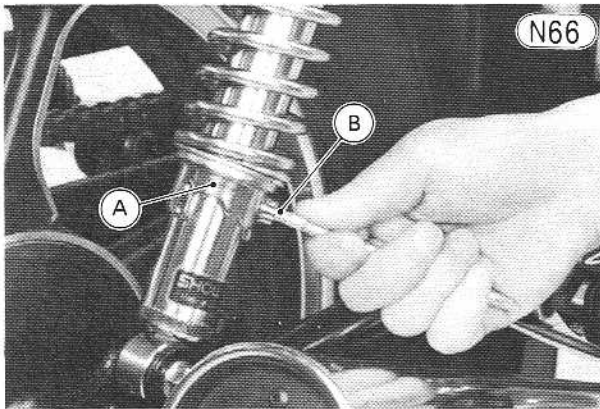

A. Adjusting Sleeve B. Screwdriver Bit

- Make sure that both adjusting sleeves are turned to the same relative position.

WARNING If the rear shock absorbers are not adjusted equally, handling may be impaired.

LUBRICATION

Refer to Pg. 29, noting the following.

Swing Arm Pivot

In order for the swing arm to function safely and wear slowly, it should be properly lubricated in accordance with the Periodic Maintenance Chart (Pg. 216). Lubrication is also necessary after disassembly.

Remove the swing arm, clean out the old grease, and apply grease to the bearings (See Fig. J37).

Disassembly

TORQUE AND LOCKING AGENT

Refer to Pg. 184, noting the following.

| Engine Part | Locking Agent (●), Liquid Gasket (★), Required | Quantity | Torque | | See Pg. |
|-------------------------------------|--|----------|---------------|------------------|---------|
| | | | Metric (kg-m) | English (ft-lbs) | |
| Engine Sprocket Holding Plate Bolts | — | 2 | 1.0 | 87 in-lbs | 225 |

CARBURETORS

Removal:

- Remove the fuel tank (Pg. 39).
- Pull out the overflow and breather tubes from between the rear of the engine and the swing arm.
- Loosen the carburetor holder clamp and the air cleaner duct clamp for earth carburetor, and slip them out of place.

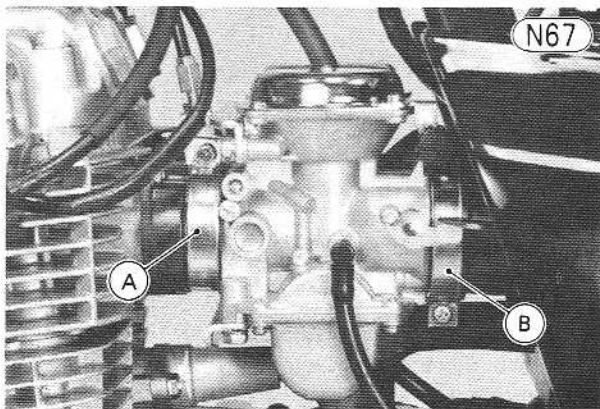

A. Carburetor Holder Clamp B. Air Cleaner Duct Clamp

- Pull the carburetors off to the rear and out. Be sure not to damage the throttle cable.

- Turn in fully the locknut and adjusting nut at the upper end of the throttle cable so as to give the cable plenty of play.

CAUTION Removing the throttle cable from the carburetors without enough cable play, may cause throttle cable damage.

- Loosen the locknut and turn out the cable adjuster on the lower end of the throttle cable all the way, to remove it from the adjuster bracket.

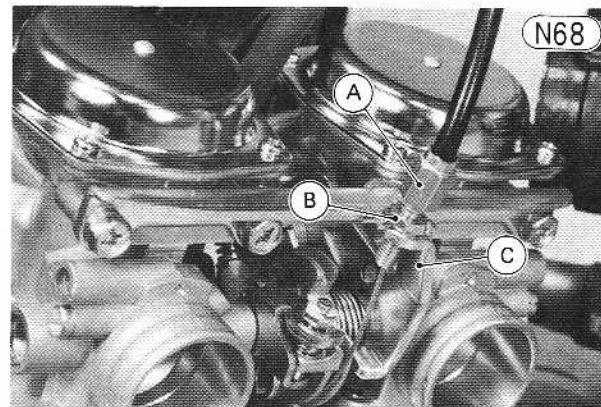

A. Adjuster B. Locknut C. Adjuster Bracket

- Disconnect the cable tip from the pulley.

Installation Notes:

1. If the carburetors were disassembled, visually synchronize the throttle (butterfly) valves as follows:
 - Check to see that both butterfly valves open and close smoothly without no binding when turning pulley.
 - Visually check the clearance between the butterfly and the carburetor bore in each carburetor.

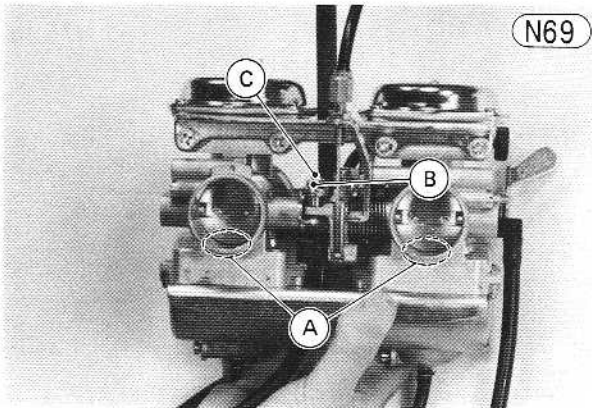

A. Clearance
B. Locknut
C. Balance Adjusting Screw

○ If both clearance differ from each other, loosen the locknut, and turn the balance adjusting screw to obtain the same clearance.

○ Tighten the locknut.

2. Check that the ducts and holders are all properly fitted on the carburetors, and tighten the clamps.
3. Route the carburetor overflow tubes (2) and breather tubes (2) to the rear of the engine.
4. Adjust the throttle cable (Pg. 217).
5. Adjust the carburetors (Pg. 22)

Carburetor Separation/Link Mechanism

The carburetor parts listed below can be removed without separating the carburetors.

| | |
|--------------------|---------------------|
| Pilot Screw | Vacuum piston |
| Jet Needle | Float |
| Valve Needle | Pilot Jet |
| Primary Main Jet | Main Jet Bleed Pipe |
| Secondary Main Jet | Needle Jet Holder |
| | Needle Jet |

- Remove the choke link screw (20) and lockwasher (21).

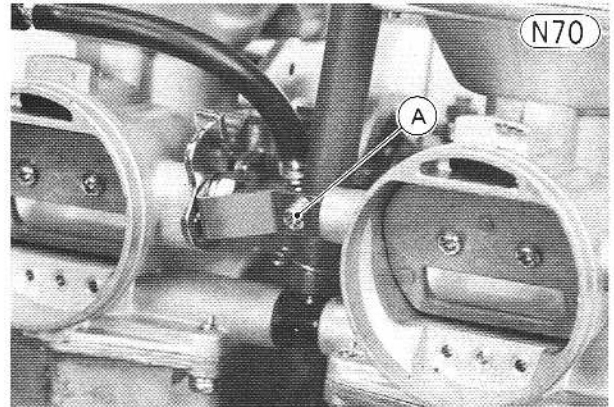

A. Choke Link Screw

- Remove the bolts (8) and lockwashers (8), and take off the upper and lower mounting plates to separate the carburetors. The linkage mechanism spring (3) and fuel hose 3-way joint come off.
- Remove the idle adjusting screw holder.
- Turn out the idle adjusting screw (9) on the left carburetor and remove it with its spring (13) and spring seat (12).
- Remove the screw with lockwasher, and remove the cable bracket assembly.
- Remove the nut and lockwasher, and remove the choke link and fast idling cam.

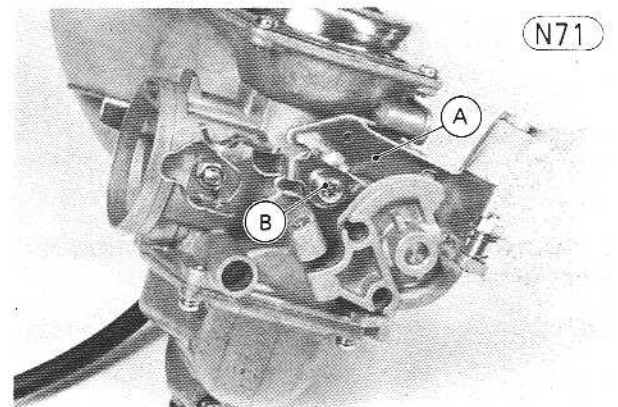

A. Cable Bracket Assembly **B. Screw**

Installation:

- Install the fast idling cam and choke link in the direction shown in figure N71 when the choke valves are completely closed.
- Install the cable bracket assembly.
- Install the idle adjusting screw with its spring and spring seat.
- Install the idle adjusting screw holder.
- Install the upper and lower mounting plates on one of the carburetors. The lower mounting bolts are longer than the upper ones.

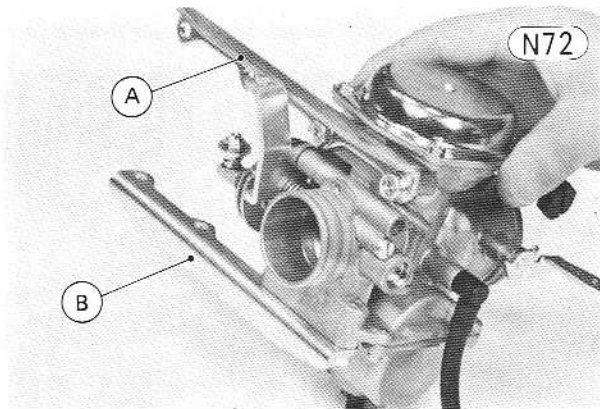

A. Upper Mounting Plate B. Lower Mounting Plate

●Check that the O rings (4) are properly in place, and install the fuel hose 3-way joint with the hose pointing upward. The Shorter side of the joint goes into the right carburetor.

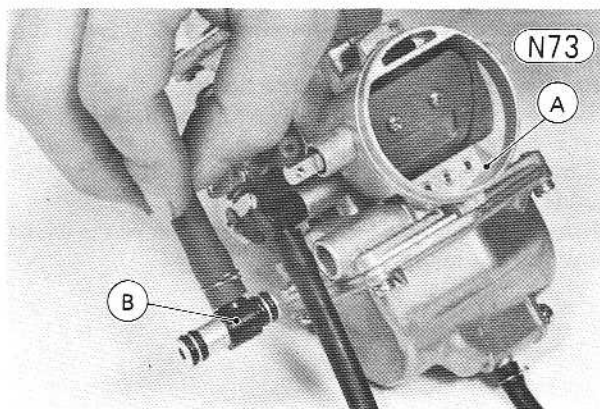

A. Right Carburetor B. 3-way Joint

●Connect both carburetors and install the linkage mechanism spring as shown below.

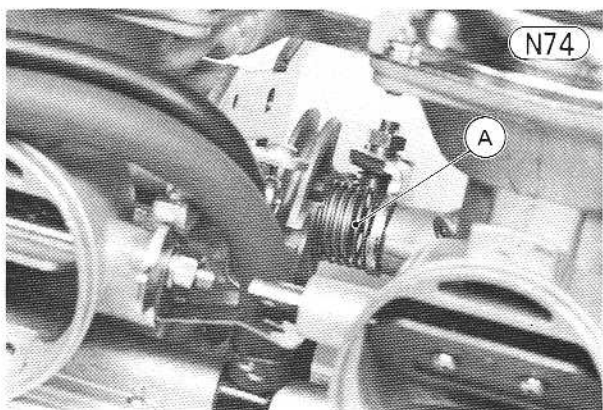

A. Spring

●Install the remaining bolts and lockwashers for the mounting plate. Check the carburetor alignment.
●Install the choke link screw and lockwasher.

●Before installing the carburetors on the motorcycle, perform the "Carburetor Function Checks".

Carburetor Function Checks:

1. Choke Valves

●Operate the choke lever to make sure that both choke valves open and close at the same time.
●If they don't, carefully bend or reposition the choke link. Tighten the nut.

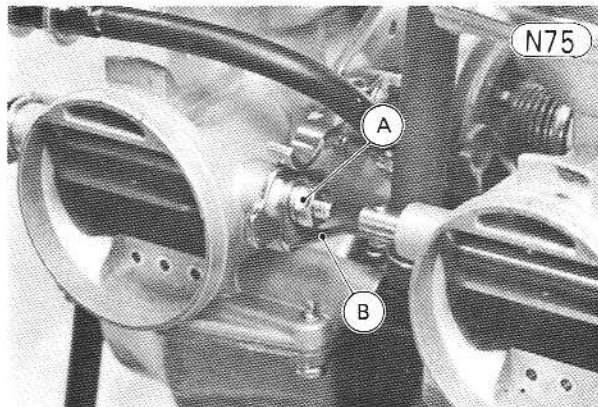

A. Nut B. Choke Link

●Push on each relief valve in the choke valves to see if it returns smoothly. If it does not, the spring behind the relief valve is weak or damaged and the carburetor body must be replaced as an assembly.

CAUTION If the relief valve or choke valve does not work properly, the proper fuel/air mixture for cold idling could be upset.

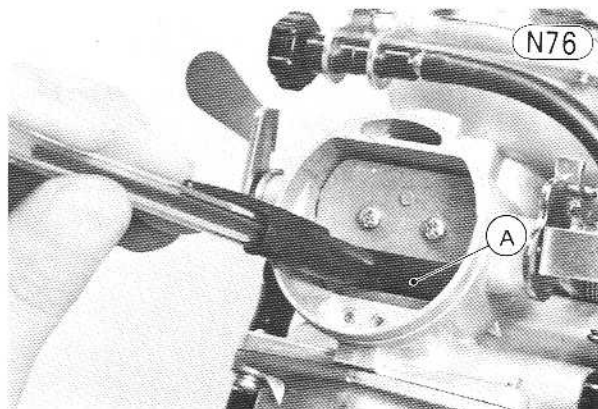

A. Relief Valve

2. Vacuum Pistons

●Check that each vacuum piston slides up and down smoothly.
●If there is any doubt, pull out the vacuum piston and check for any damage.
●Situate the carburetors upright, set the vacuum piston at its topmost position, block the air passage hole to prevent air from entering through it, and release the piston. The piston should slide down very slowly (It should take more than ten seconds).

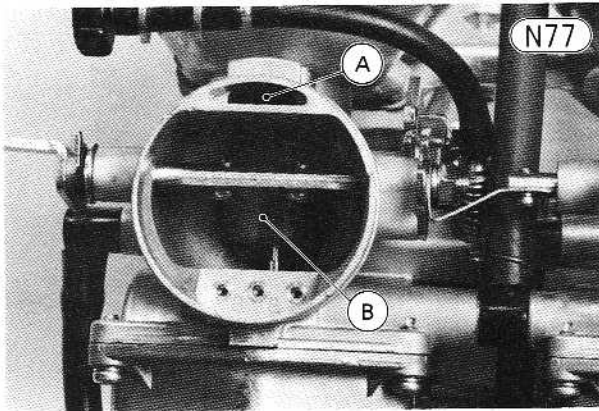

A. Air Passage Hole B. Vacuum Piston

●If it does not, the diaphragm or piston is probably damaged and must be replaced.

CAUTION If the diaphragm or vacuum piston does not work properly, engine malfunction could result.

3. Fast Idling Cam

- Turn out the idle adjusting screw until there is clearance between it and the pulley.
- Open the choke valves fully and push up the idling link until the pulley begins to rotate. At this time, the clearance between the idling link and the fast idling cam should be about 1.0 mm.

CAUTION If the clearance is larger, the cold idle speed will be too low and the engine will stall. If the clearance is smaller, the cold idle speed will be too high.

Fast Idling Cam

N78

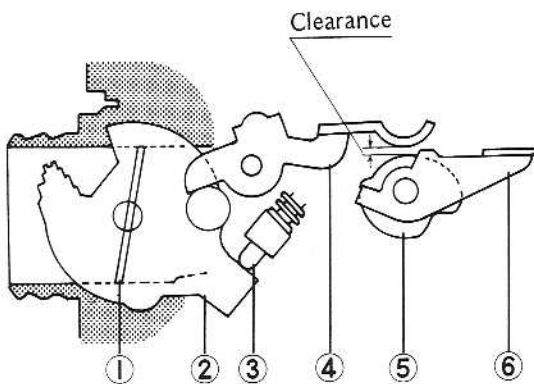

- | | |
|-------------------------|----------------|
| 1. Choke Valve | 4. Idling Link |
| 2. Pulley | 5. Idling Cam |
| 3. Idle Adjusting Screw | 6. Choke Lever |

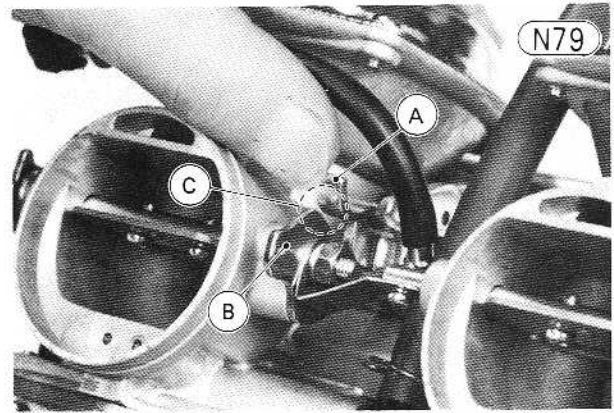

A. Idling Link B. Fast Idling Cam C. About 1 mm

●If the clearance is incorrect, carefully bend the idling link as required. Recheck the clearance.

4. Butterfly Valves

- Make sure that the butterfly valves open and close smoothly as the pulley is rotated. If they don't, check for binding in the carburetor bore or spring damage, and correct as necessary.
- Turn out the idle adjusting screw until there is clearance between it and the pulley. Open the choke valves. Then, check that both butterfly valves close completely and that they begin to open at the same time.

CAUTION If the butterfly valves do not work simultaneously, stable idling or satisfactory carburetor synchronization cannot be achieved.

●If adjustment is necessary, loosen the locknut and turn the adjusting screw on the pulley as required. Tighten the locknut.

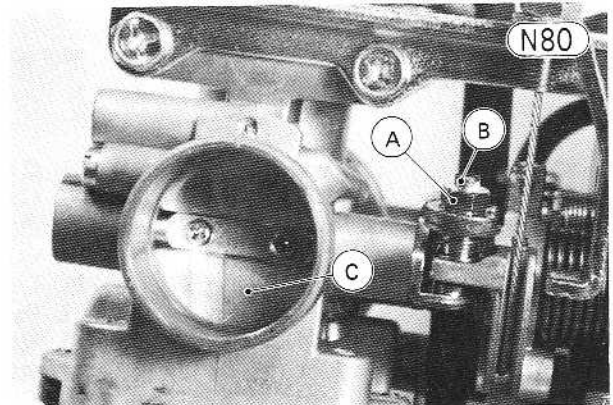

A. Locknut B. Adjusting Screw C. Butterfly Valve

5. Service Fuel Level

Situate the carburetors so that they are perfectly level, and measure the service fuel level for each carburetor, and adjust it if necessary (Pg. 118).

CAUTION If the service fuel level is incorrect, the proper fuel/air mixture for good engine performance cannot be obtained.

Carburetors

N81

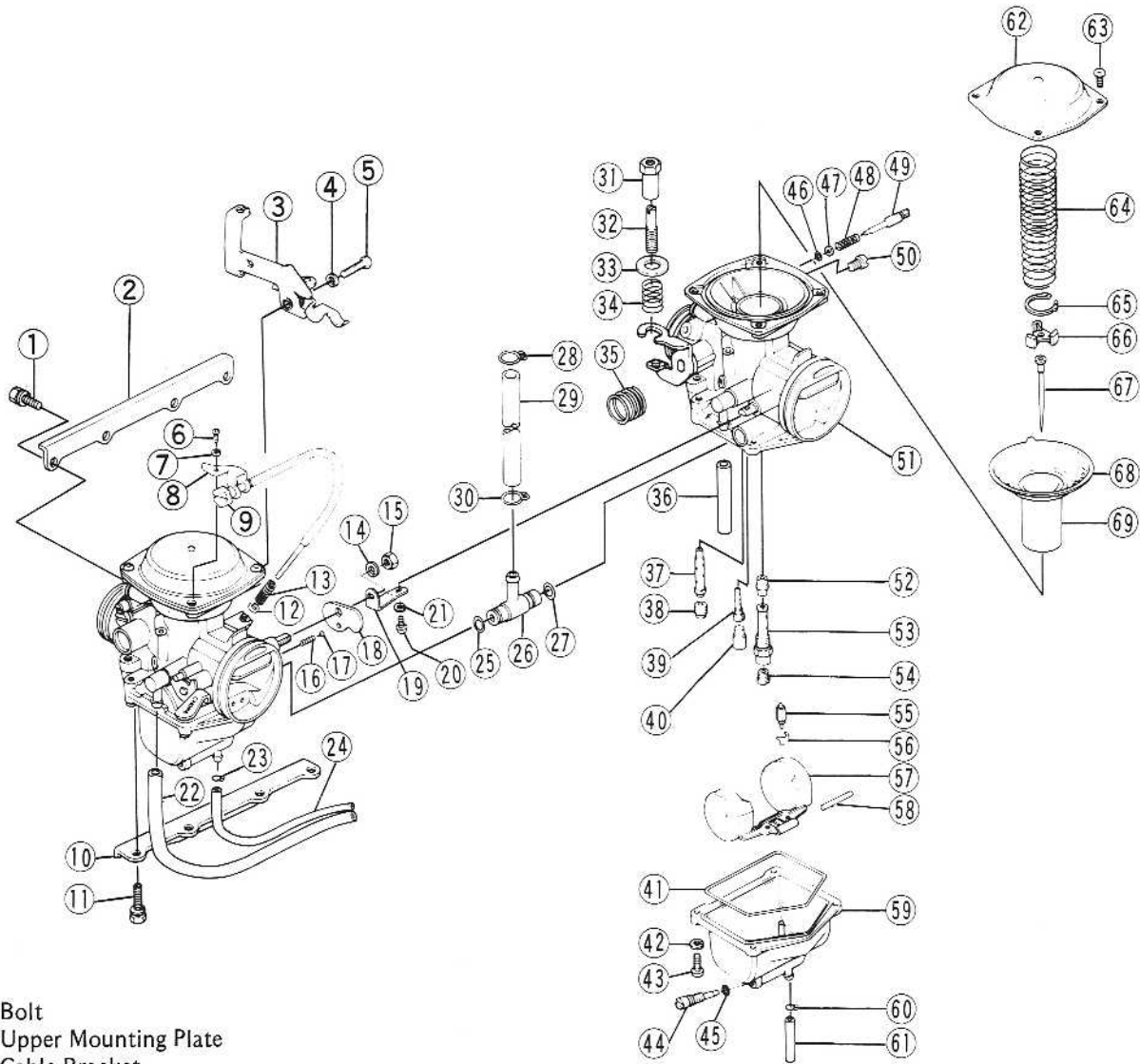

- 1. Bolt
- 2. Upper Mounting Plate
- 3. Cable Bracket
- 4. Lockwasher
- 5. Screw
- 6. Screw
- 7. Lockwasher
- 8. Idle Adjusting Screw Holder
- 9. Idle Adjusting Screw
- 10. Lower Mounting Plate
- 11. Bolt
- 12. Spring Seat
- 13. Spring
- 14. Lockwasher
- 15. Nut
- 16. Spring
- 17. Steel Ball
- 18. Idling Cam
- 19. Choke Link
- 20. Screw
- 21. Lockwasher
- 22. Breather Tube
- 23. Clip
- 24. Overflow Tube
- 25. O Ring
- 26. 3-way Joint

- 27. O Ring
- 28. Clip
- 29. Fuel Hose
- 30. Clip
- 31. Locknut
- 32. Balance Adjusting Screw
- 33. Washer
- 34. Spring
- 35. Spring
- 36. Breather Tube
- 37. Bleed Pipe
- 38. Primary Main Jet
- 39. Pilot Jet
- 40. Rubber Plug
- 41. O Ring
- 42. Lockwasher
- 43. Screw
- 44. Drain Screw
- 45. O Ring
- 46. O Ring
- 47. Flat Washer

- 48. Spring
- 49. Pilot Screw
- 50. Vacuum Plug
- 51. Carburetor Body
- 52. Needle Jet
- 53. Needle Jet Holder
- 54. Secondary Main Jet
- 55. Float Valve Needle
- 56. Hanger Clip
- 57. Float
- 58. Float Pin
- 59. Float Bowl
- 60. Clip
- 61. Overflow Tube
- 62. Upper Chamber Cover
- 63. Screw
- 64. Spring
- 65. Circlip
- 66. Jet Needle Holder
- 67. Jet Needle
- 68. Diaphragm
- 69. Vacuum Piston

Carburetor Disassembly (each carburetor):

- Remove the screws (4) and the upper chamber cover (62) and spring (64).
- Being careful not to damage the diaphragm, pull out the diaphragm/vacuum piston assembly. Do not use the sharp edge of a tool to separate the diaphragm from the groove.
- Remove the circlip (65) using inside circlip pliers (special tool) and remove the jet needle holder (66) and jet needle (67).
- Remove the pilot screw (49), spring (48), flat washer (47), and O-ring (46).
- Remove the screws (4) and lockwashers (4), and remove the float bowl (59) and O-ring (41).
- Pull out the float pin (58), remove the float (57), and pull out the valve needle (55) with its longer clip (56).
- Remove the primary main jet (38) and the main jet bleed pipe (37).
- Remove the secondary main jet (54) and the jet needle holder (53).
- Pull off the rubber plug (40) and remove the pilot jet (52).

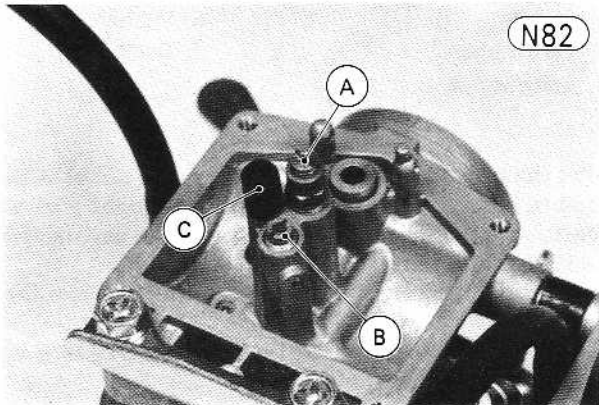

A. Secondary Main Jet
B. Primary Main Jet
C. Plug

Assembly Notes:

1. Replace any O-rings and rubber plugs if they are damaged or deteriorated.
2. Align the diaphragm tongue with the notch in the upper chamber, and fit the diaphragm sealing lip into its groove.

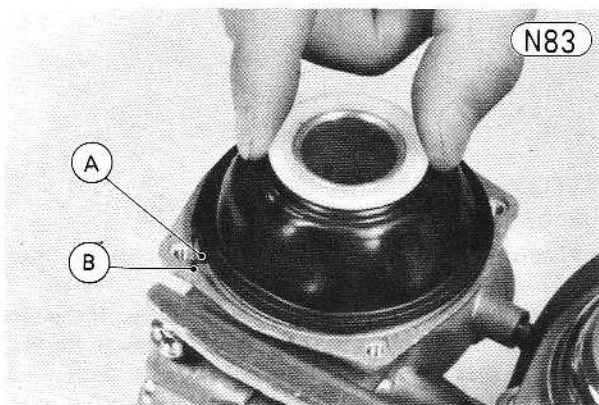

A. Diaphragm Tongue
B. Notch

3. When assembling the float valve needle, hook its hanger clip to the tang on the float.

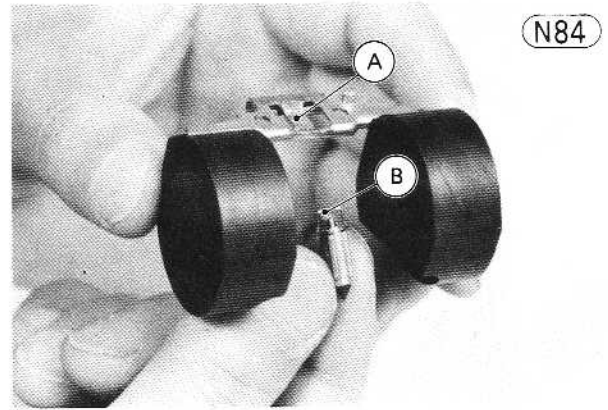

A. Tang
B. Clip

4. Turn in the pilot screw fully but not tightly and then back it out 2½ turns.

CAMSHAFT CHAIN TENSIONER

Removal:

- Remove the breather hose.
- Loosen the lock bolt (9) before tensioner removal.
- Unscrew the bolts, and remove the camshaft chain tensioner body (4) and O-ring (3).

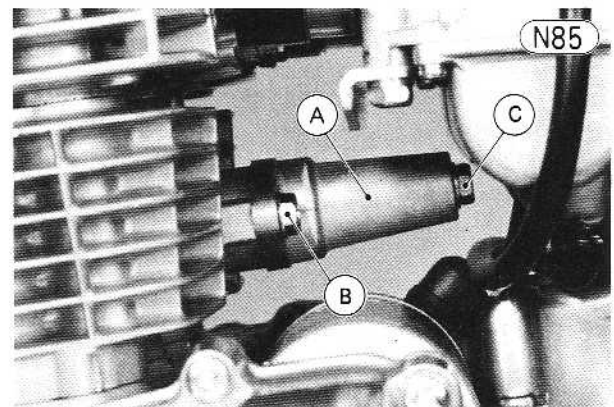

A. Tensioner
B. Mounting Bolt
C. Lock Bolt

- CAUTION**
1. When removing the chain tensioner, do not take out the mounting bolts only halfway. Retightening the mounting bolts from this position could damage the chain tensioner and the camshaft chain. Once the bolts are loosened, the tensioner must be removed and reset as described below.
 2. Do not turn over the crankshaft while the camshaft chain tensioner is removed. This could upset the camshaft chain timing, and damage the engine.
- Take the long spring (8), flat washer (7), balls and retainer (5), short spring (2), and push rod (1) and circlip (6) out of the cylinder block.

Camshaft Chain Tensioner

N86

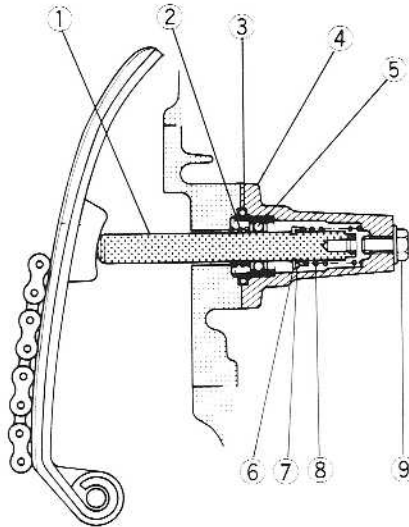

- | | | |
|-----------------|-----------------------|----------------|
| 1. Push Rod | 4. Tensioner Body | 7. Flat Washer |
| 2. Short Spring | 5. Balls and Retainer | 8. Long Spring |
| 3. O-ring | 6. Circlip | 9. Lock Bolt |

Installation:

- Clean all parts of the tensioner using a high flash-point solvent, and apply clean engine oil to the parts.

CAUTION The dirt or grime on the push rod can cause the tensioner malfunctioning.

- Back out the lock bolt several turns.
- Put the flat washer and long spring on the push rod end that has two parallel flat surfaces.

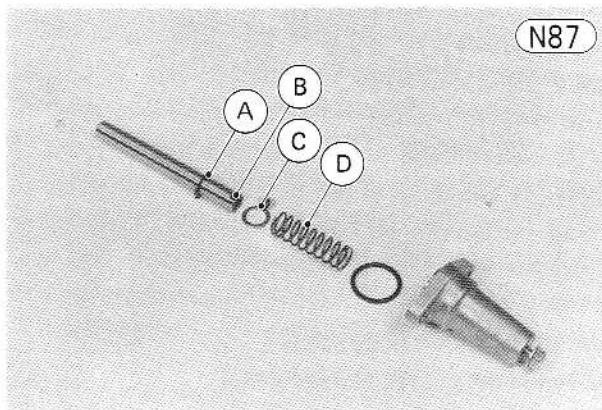

N87

- | | |
|-----------------|----------------|
| A. Circlip | C. Flat Washer |
| B. Flat Surface | D. Long Spring |

- Compressing the spring, push the push rod into the tensioner body until the rod flattened end engages with the recess at the bottom of the tensioner body.
- Holding the push rod in this position, turn in the lock bolt through the tensioner body into the rod to keep the rod in place.

CAUTION Do not use any bolt longer than 14 mm. A bolt longer than 14 mm could damage the camshaft chain.

WARNING Never loosen the lock bolt before installing the tensioner on the cylinder block. Loosening the lock bolt may cause injury by jumping the push rod out of the tensioner body.

Push Rod Locking

N88

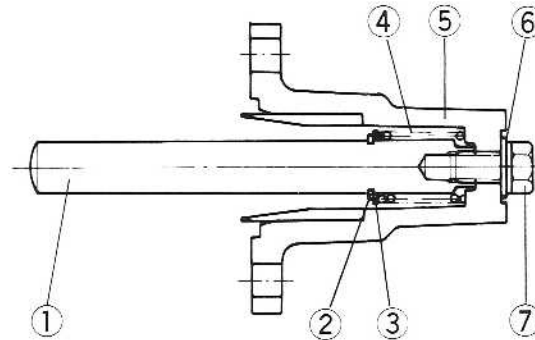

- | | |
|----------------|-------------------|
| 1. Push Rod | 5. Tensioner Body |
| 2. Circlip | 6. Washer |
| 3. Flat Washer | 7. Lock Bolt |
| 4. Long Spring | |

- Put the balls and retainer, and small spring on the push rod in this sequence, and fit the O-ring into the groove.
- Install the tensioner on the cylinder block, and tighten the mounting bolts.
- Loosen the lock bolt several turns until it releases the push rod.
- Tighten the lock bolt to 1.0 kg-m (87 in-lbs) of torque.
- Install the breather hose.

CYLINDER BLOCK

Refer to Pgs. 52–53, noting the following.

1. The piston holders (special tool: P/No. 57001-1023) can not be used to hold the piston during cylinder block installation because of the crankcase modification. Install the cylinder block carefully using the piston ring compressor assembly (special tool: P/No. 57001-1094) not to damage the piston rings.

PISTON, PISTON RINGS

Removal and Installation:

Piston ring installation procedures are changed. See Pgs. 53–54 with the following exception.

1. Install the top ring in the top most groove. If the top ring has an "T" mark near the ring end, install the top ring so that the "T" mark side faces up. If there is no marks on the ring, the ring can be installed with either side facing up.

ENGINE SPROCKET

Removal:

- Stand the motorcycle up on its center stand.
- Check that the transmission is in neutral.
- Remove the engine sprocket cover (Pg. 54).
- Remove the cotter pin, and loosen the rear axle nut.

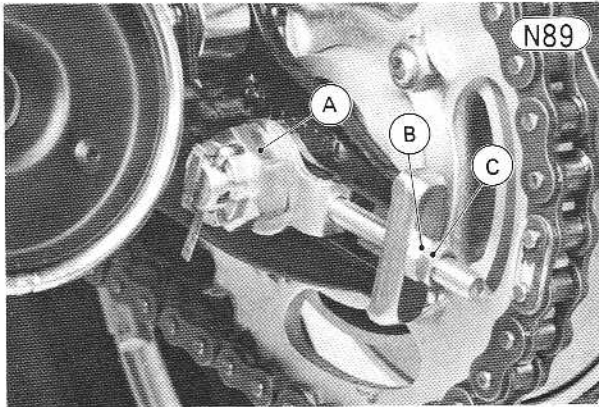

A. Axle Nut C. Chain Adjuster Locknut
B. Chain Adjusting Nut

- Loosen the nut at the rear end of the torque link.

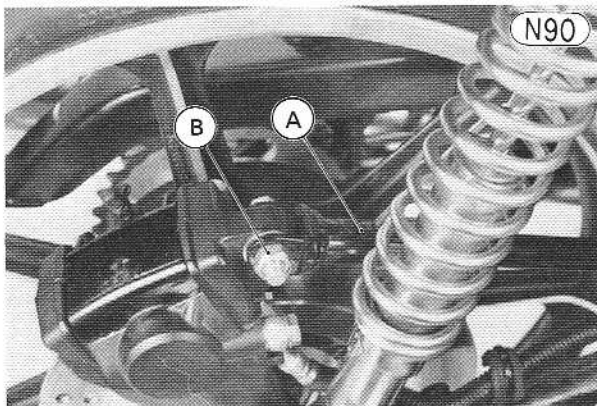

A. Torque Link B. Nut

- Loosen the left and right chain adjuster locknuts, and then back out the chain adjusting nuts. Kick the wheel forward to give the chain plenty of play.
- Remove the engine sprocket holding plate bolts (2), and remove the plate and engine sprocket.

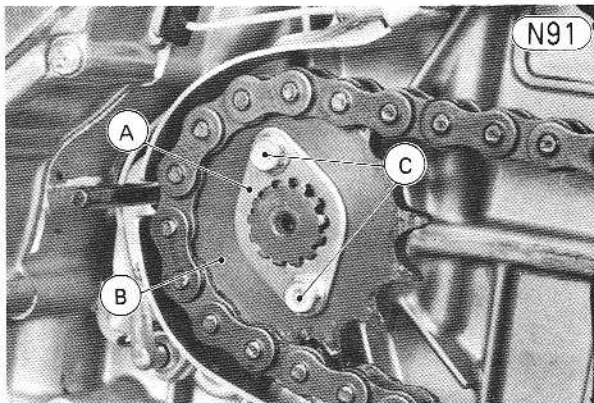

A. Engine Sprocket Holding Plate C. Bolts
B. Engine Sprocket

Installation:

- Mount the engine sprocket while meshed with the drive chain.
- Install the engine sprocket holding plate, and then tighten the holding plate bolts (2) to 1.0 kg-m (87 in-lbs) of torque.
- Install the engine sprocket cover (Pg. 55).
- Adjust the drive chain (Pg. 24).

TRANSMISSION

Output Shaft Disassembly and Assembly:

Refer to Pg 86, noting the following.

1. The 5th gear (5) has three steel balls assembled into it for neutral positioning. To remove this gear with the balls, quickly spin the shaft in a vertical position while holding 4th gear (4) and pull off the 5th gear upwards.
2. Do not use grease on the three balls during assembly; these balls must be able to move freely.

Steel Balls Installation

N92

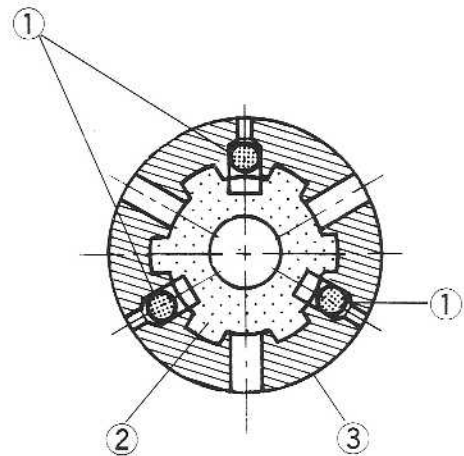

1. Steel Balls
2. Output Shaft
3. 5th Gear

FRONT WHEEL

The procedures are the same as those for the 1979 Z250-A1 with the following exception. Refer to Pg. 89.

Front Hub Disassembly and Assembly:

1. Speedometer gear drive has been changed and speedometer gear drive holding plate is deleted.

Front Hub

N93

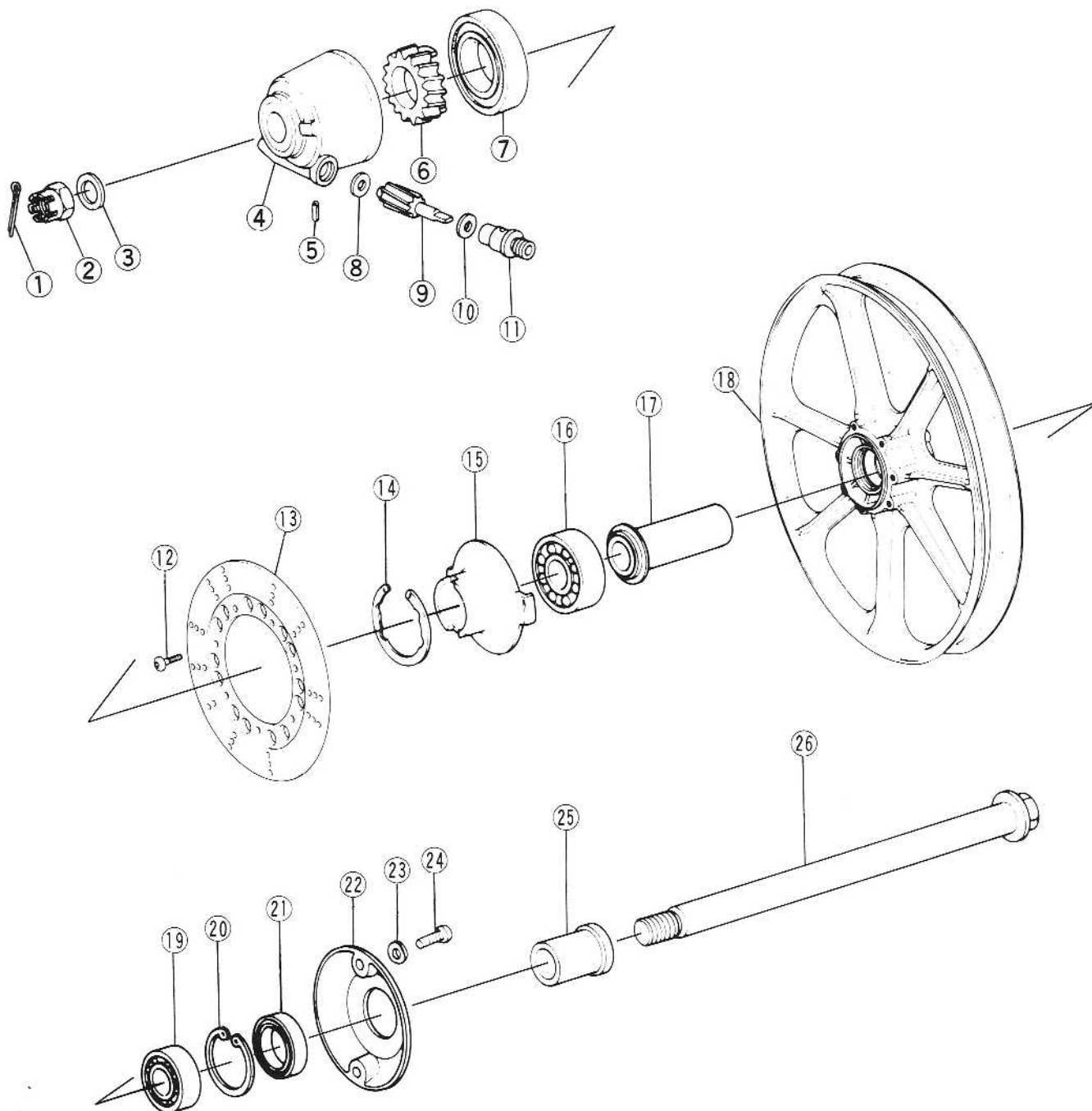

- 1. Cotter pin
- 2. Axle Nut
- 3. Washer
- 4. Speedometer Gear Housing
- 5. Pin
- 6. Speedometer Gear
- 7. Grease Seal
- 8. Washer

- 9. Speedometer Pinion
- 10. Washer
- 11. Bushing
- 12. Bolt
- 13. Disc
- 14. Circlip
- 15. Speedometer Gear Drive
- 16. Ball Bearing

- 17. Distance Collar
- 18. Wheel
- 19. Ball Bearing
- 20. Circlip
- 21. Grease Seal
- 22. Cap
- 23. Washer
- 24. Screw
- 25. Collar
- 26. Front Axle

- Mount the brake disc on the wheel so that the marked side faces out.

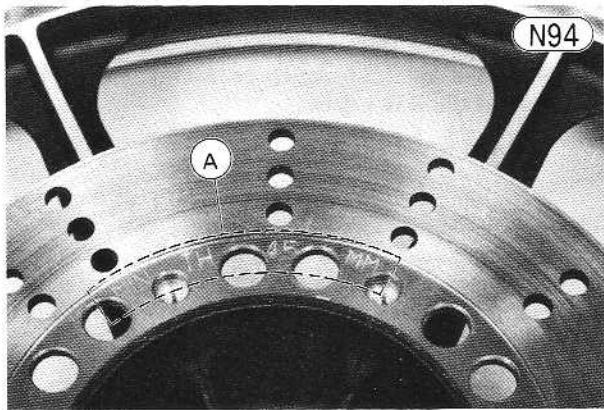

A. Marking

FRONT BRAKE

The procedures are the same as those for the 1979 Z250-A1 with the following exception. See Pgs. 92–97.

Tightening torque for the parts related to disc brake is changed as shown in Table N18.

Table N18 Disc Brake Torque

| | | |
|--------------------------------|-----------|-------------|
| Bleed valve | 0.80 kg-m | 69 in-lbs |
| Brake lever pivot bolt | 0.30 kg-m | 26 in-lbs |
| Brake lever pivot bolt locknut | 0.60 kg-m | 52 in-lbs |
| Caliper holder shaft bolts | 1.80 kg-m | 13.0 ft-lbs |
| *Caliper mounting bolts | 4.0 kg-m | 29 ft-lbs |
| Disc mounting Allen bolts | 2.3 kg-m | 16.5 ft-lbs |
| Fitting (banjo) bolts | 3.0 kg-m | 22 ft-lbs |
| *Master cylinder clamp bolts | 0.90 kg-m | 78 in-lbs |

*: Retorque these parts according to Periodic Maintenance Chart (Pg. 216).

Pad Removal:

- Remove the caliper holder shaft bolts (2).

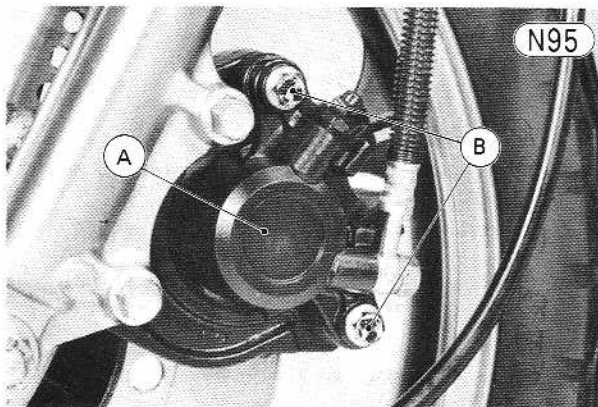

A. Caliper B. Holder Shaft Bolts

- Lift the caliper off the holder, and remove the pads.

Pad Installation:

- Remove the bleed valve cap on the caliper, attach a clear plastic hose to the bleed valve, and run the other end of the hose into a container.
- Open (loosen) the valve slightly, push the piston in by hand as far as it will go, and then close (tighten) the valve. Wipe up any spilled fluid, and recap the bleed valve. The bleed valve must be tightened to 0.80 kg-m (69 in-lbs) of torque.

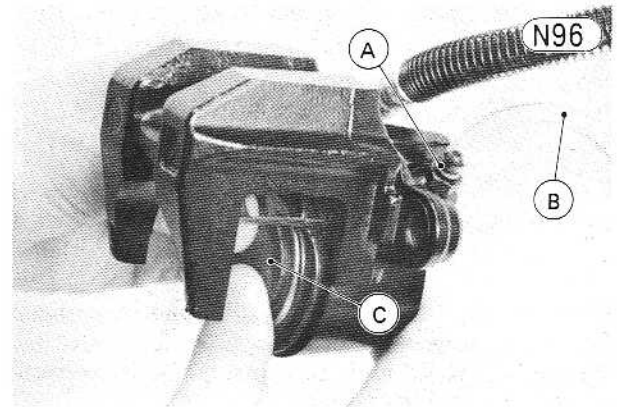

A. Bleed Valve B. Hose C. Piston

- Check that the sliders (2) are in place.
- Fit the pads against the disc.

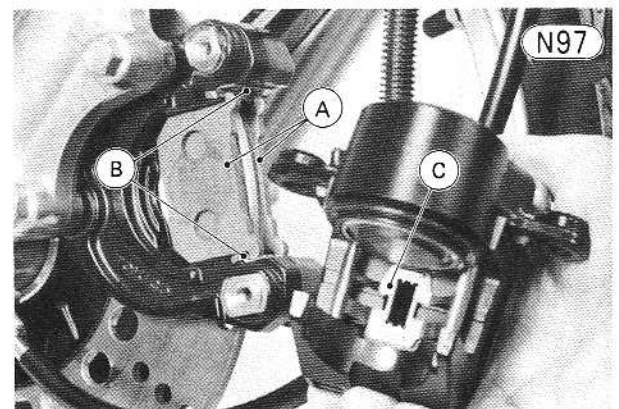

A. Pads B. Sliders C. Anti-Rattle Spring

- Check that the anti-rattle spring is in place. If it was removed, install it to the caliper as shown in Fig. N102.
- Install the caliper, and tighten the caliper holder shaft bolts to 1.8 kg-m (13.0 ft-lbs) of torque.
- Since some brake fluid was lost when the bleed valve was opened, check the fluid level in the master cylinder and bleed the air from the brake system (Pg. 145).
- Check the brake.

WARNING Do not attempt to drive the motorcycle until a full brake lever is obtained by pumping the brake lever until the pads are against the disc. The brake will not function on the first application of the lever if this is not done.

Caliper Removal:

- If the caliper is to be disassembled, loosen the caliper holder shaft bolts (2).

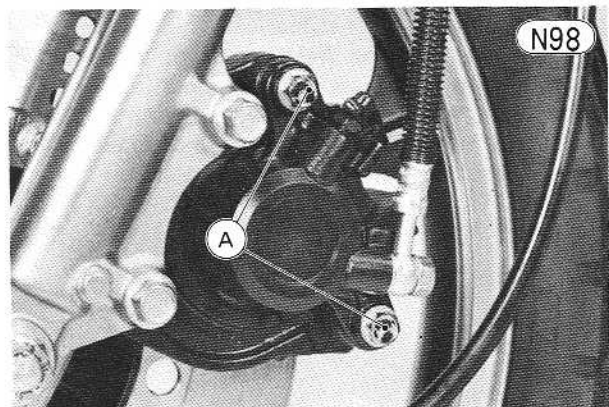

A. Holder Shaft Bolts

NOTE: If the caliper is to be disassembled after caliper removal and compressed air is not available, remove the piston using the following two steps before disconnecting the brake hose fitting from the caliper.

- Remove the pads (Pg. 227)
- Pump the piston out with the brake lever.
- Remove the banjo bolt at the caliper, and temporarily secure the end of the brake hose to some high place to keep fluid loss to a minimum. There is a flat washer on each side of the hose fitting.

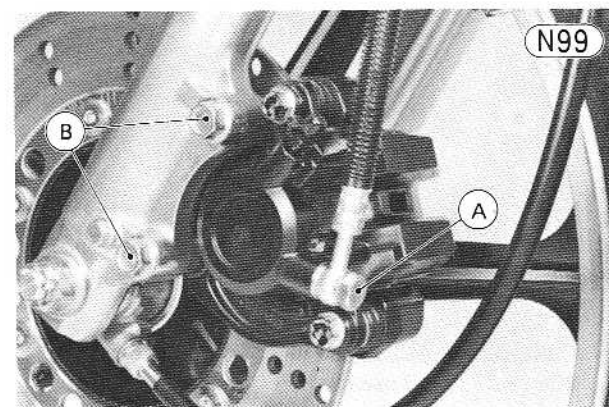

A. Banjo Bolt B. Mounting Bolts

- Remove the mounting bolts (2), and take off the caliper.

Caliper Installation Notes:

1. Tighten the front caliper mounting bolts to 4.0 kg-m (29 ft-lbs) of torque.
2. Tighten the caliper holder shaft bolts to 1.8 kg-m (13.0 ft-lbs) of torque.
3. Connect the brake hose to the caliper putting a new flat washer on each side of the brake hose fitting. Tighten the banjo bolt to 3.0 kg-m (22 ft-lbs) of torque.

4. Check the fluid level in the master cylinder, and bleed the brake line (Pg. 145)

WARNING Do not attempt to drive the motorcycle until a full brake lever is obtained by pumping the brake lever until the pads are against the disc. The brake will not function on the first application of the lever if this is not done.

Caliper Disassembly:

- Remove the caliper holder shaft bolts (9) (2), and pull out the caliper holder (7) and the pads (16) (2).
- Remove the holder shafts (4) and (14) with the dust covers (5). There is the friction boot (15) on the shaft (14) that diameter is smaller than the other.
- Remove the anti-rattle spring (10).
- Remove the dust seal (13) around the piston (12).
- Cover the caliper opening with a clean, heavy cloth, and remove the piston by lightly applying compressed air to where the brake line fits into the caliper.

WARNING To avoid serious injury, never place your fingers or palm inside the caliper opening. If you apply compressed air into the caliper, the piston may crush your hand or fingers.

NOTE: If compressed air is not available, reconnect the brake line and pump the piston out with the brake lever.

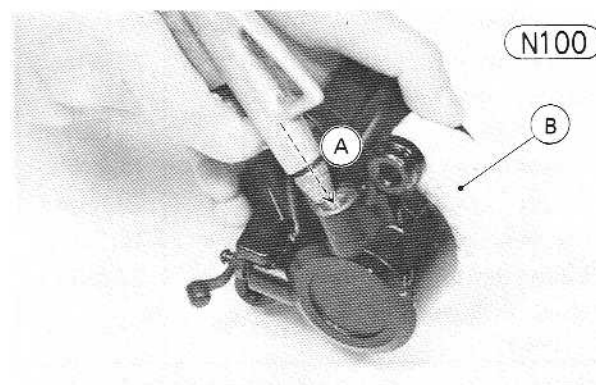

A. Compressed Air B. Heavy Cloth

- Taking care not to damage the cylinder surface, remove the fluid seal (11) with a hook.

Caliper Assembly Notes:

1. Clean the caliper parts with brake fluid or alcohol (See CAUTION — Pg. 92).
2. It is recommended that the fluid seal, which is removed, be replaced with a new one.
3. Replace the dust covers and friction boot if they were damaged.
4. Apply brake fluid to the outside of the piston and the fluid seal, and push the piston into the cylinder by hand. Take care that neither the cylinder nor the piston skirt get scratched.

5. Install the dust seal around the piston. Check that the dust seal is properly fitted into the grooves in the piston and caliper.

Caliper Dust Seal, Fluid Seal

N101

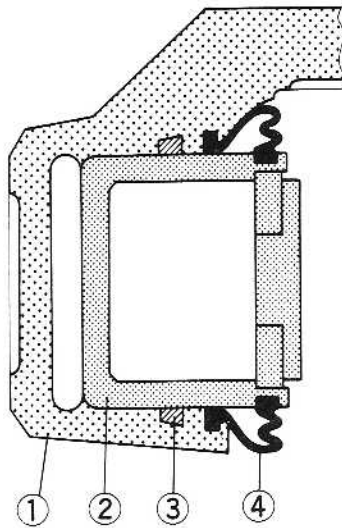

- 1. Caliper
- 2. Piston
- 3. Fluid Seal
- 4. Dust Seal

6. Apply a thin coat of PBC (Poly Butyl Cuprysil) grease to the caliper holder shafts and holder holes. (PBC grease is a special high temperature, water-resistance grease).

7. Install the anti-rattle spring to the caliper as shown.

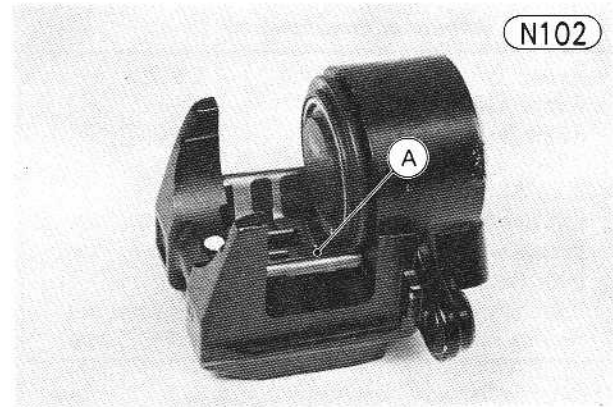

A. Anti-rattle Spring

8. Do not forget to tighten the holder shaft bolts after installing the caliper on the motorcycle.

Front Caliper

N103

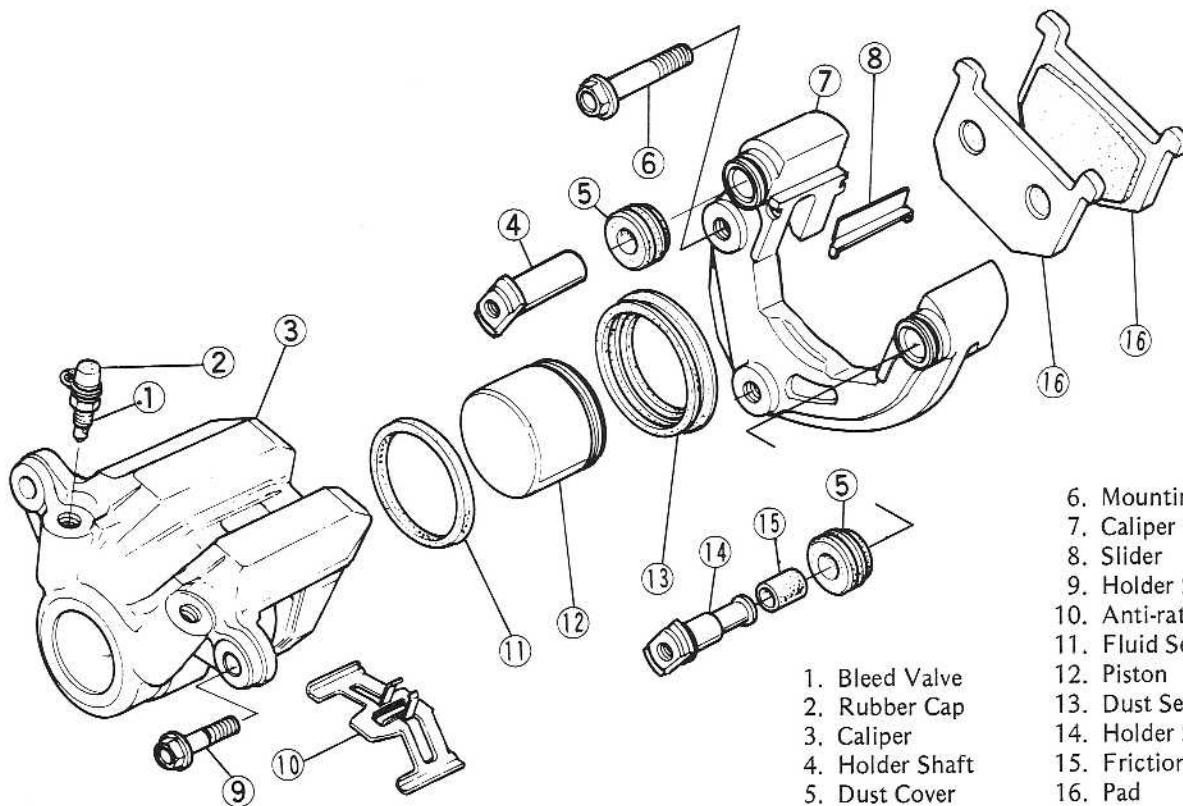

- 1. Bleed Valve
- 2. Rubber Cap
- 3. Caliper
- 4. Holder Shaft
- 5. Dust Cover
- 6. Mounting Bolt
- 7. Caliper Holder
- 8. Slider
- 9. Holder Shaft Bolt
- 10. Anti-rattle Spring
- 11. Fluid Seal
- 12. Piston
- 13. Dust Seal
- 14. Holder Shaft
- 15. Friction Boot
- 16. Pad

Maintenance

CARBURETORS

Refer to Pgs. 115 – 119, noting the following.

Table N19 Carburetor Specifications

| | |
|---------------------------|--------------|
| Type | CV 32 |
| Primary Main Jet | #60 |
| Secondary Main Jet : Left | # 80 |
| Right | # 85 |
| Pilot Air Jet | # 130 |
| Primary Main Air Jet | # 150 |
| Secondary Main Air Jet | # 60 |
| Pilot Jet | # 35 |
| Pilot Screw | 2½ turns out |
| Service Fuel Level | 1.5~3.5 mm |

CAMSHAFT CHAIN, GUIDES, TENSIONER

Refer to Pgs. 120 – 121, noting the following.

Chain guide wear

Table N20 Camshaft Chain Guide Wear

| | Front | Rear |
|---------------|--------|--------|
| Service Limit | 1.4 mm | 2.0 mm |

Chain tensioner inspection

Table N21 Chain Tensioner Spring Free Length

| | |
|---------------|-------|
| Service Limit | 39 mm |
|---------------|-------|

CYLINDER HEAD, VALVES

Valve seat cutters (special tools) are newly designed, and the repair procedures are changed a little. But, new seat cutters are available for the models before 1981 model. Refer to Pgs. 121 – 126 noting the following.

Valve, Valve Guide, Valve Seat

Valve Seat Inspection

The valve must seat in the valve seat evenly around the circumference over the specified area. If the seating area is too wide, the seating pressure per unit of area is reduced, which may result in compression leakage and carbon accumulation on the seating surface. If the seating area is too narrow, heat transfer from the valve is reduced and the valve will overheat and warp. Uneven seating or seat damage will cause compression leakage.

- Remove the valve, and check to see if the valve and valve guide are in good condition before valve seat inspection.
- Apply machinist's dye to the valve seat, and then use a lapper to tap the valve lightly into place.
- Remove the valve, and note where the dye adheres to the valve seating surface. The distribution of the dye on the seating surface gives an indication of seat condition.

- If the distribution of the dye shows uneven seating or seat damage, or if the with or outside diameter of seating surface is out of the specified range, repair the valve seat.

Table N22 Valve Seating Surface

| | Inlet | Exhaust |
|------------------|------------|------------|
| Outside Diameter | 29.0 mm | 25.0 mm |
| Width | 0.5–1.0 mm | 0.5–1.0 mm |

Valve and Valve Seat

(N104)

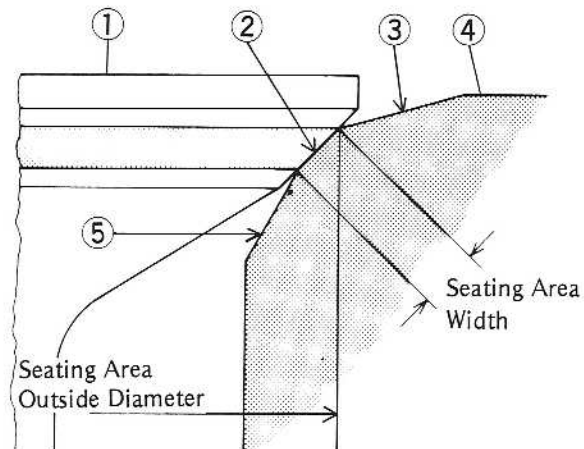

1. Valve
2. Seating Surface (45°)
3. Outer Surface (32°)
4. Valve Seat
5. Inner Surface (60°)

Valve Seat Repair

A valve seat which requires repair is cut with a set of valve seat cutters. Five seat cutters are required for complete repair; two 32°; two 45°; and one 60° seat cutters, one for the inlet and the other for the exhaust. **NOTE:** When using the cutter, be sure to apply engine oil to the cutting part before grinding and also wipe off ground particles adhering to the cutter with washing oil.

- First, cut the seating surface of the valve seat with the 45° seat cutter, cutter holder and bar (special tools). Cut only the amount necessary to make a good surface; overcutting will reduce the valve clearance, possibly making it no longer adjustable.

Cutting Valve Seat

N105

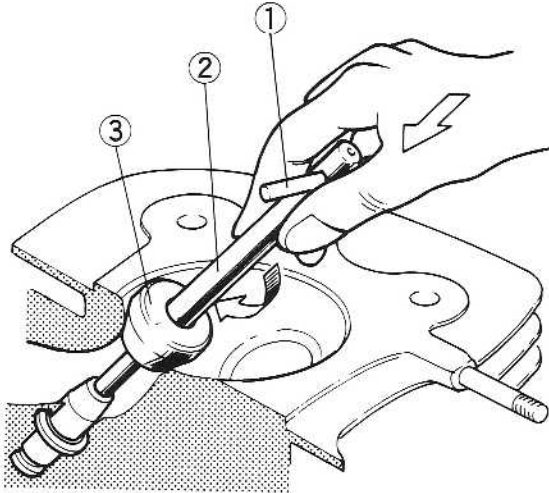

1. Bar (57001-1128)
2. 5.5 mm Cutter Holder (57001-1125)
3. Seat Cutter

First Step

N106

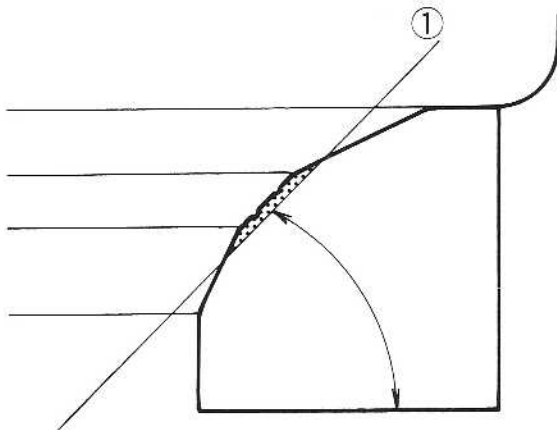

1. Cut Seating Surface with following cutters.
Exhaust : #2 Seat Cutter (57001-1114)
Inlet : #3 Seat Cutter (57001-1115)

- Next, cut the outermost surface with the outside cutter so that the valve seating surface will have the specified outside diameter.
- Then, cut the surface inside the seating surface with inside cutter so that the seating surface will have the specified width.

Second Step

N107

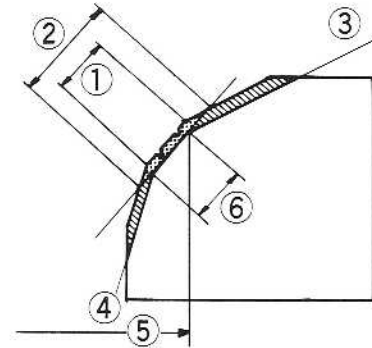

1. Original Seating Surface
2. New Seating Surface
3. Cut this surface to adjust outside diameter (5) of new seating surface with following cutters.
Exhaust : #7 Outside Cutter (57001-1119)
Inlet : #9 Outside Cutter (57001-1121)
4. Cut this surface to obtain correct width (6) with following cutter.
Inlet and Exhaust: #11 Inside Cutter (57001-1123)
5. Outside Diameter
6. Seating Area Width

After cutting, lap the valve to properly match the valve and valve seat surfaces. Start off with coarse lapping compound, and finish with fine compound.

- Apply compound to the valve seat, and tap the valve lightly into place while rotating it with a lapper, repeating this until a smooth, matched surface is obtained.
- When lapping is completed, check the valve installed height and adjust if necessary.

Lapping Valve Seat

N108

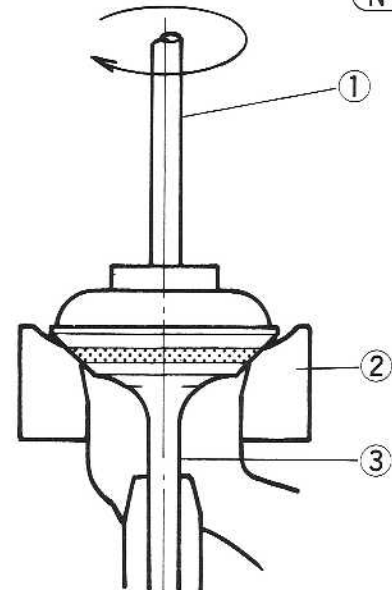

1. Lapper
2. Valve Seat
3. Valve

TRANSMISSION

Refer to Pgs. 133 – 135, noting the following.

External shift mechanism inspection

Table N23 Shift Arm Spring, Shift Positioner Springs Free Length

| | Service Limit |
|--------------------|---------------|
| Shift Arm | 19 mm |
| Neutral Positioner | 23 mm |
| Gear Positioner | 24 mm |

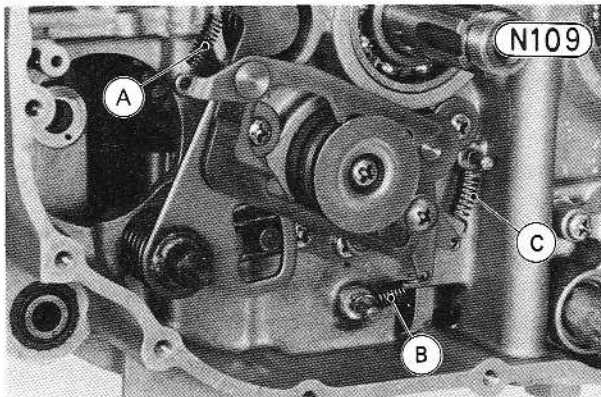

A. Shift Arm Spring **C. Gear Positioner Spring**
B. Neutral Positioner Spring

SWING ARM

Refer to Pg. 153, noting the following.

Swing arm lubrication

Because the grease nipple is deleted from the swing arm, the swing arm should be removed for its lubricating.

IGNITION SYSTEM

Refer to Pgs. 160 – 163, noting the following.

Ignition Timing/Engine Speed Relationship

(N110)

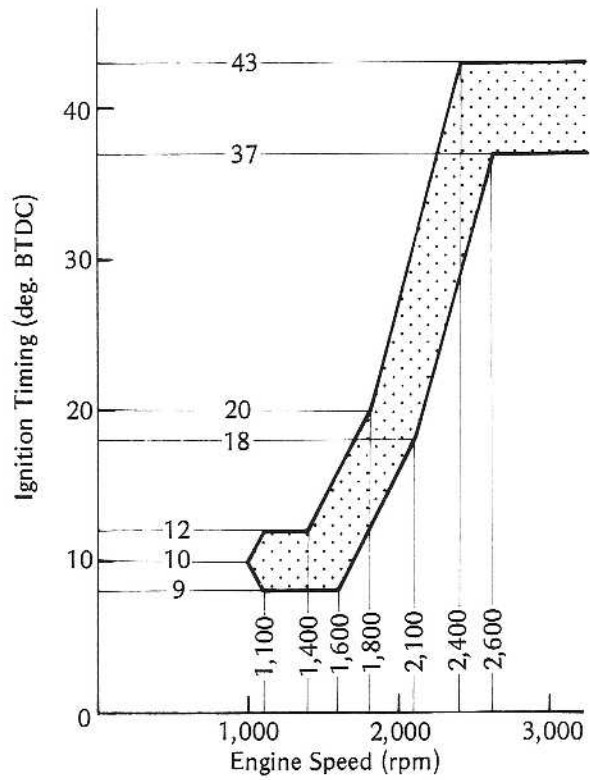

Appendix

SPECIAL TOOLS

Refer to Pgs. 175~178, noting the following.

- (a) The piston holders (P/No. 57001-1023) can not be used to hold the piston during cylinder block installation because of the crankcase modification.
- (b) The engine sprocket holder (P/No. 57001-307) is not necessary to hold the engine sprocket during engine sprocket removal and installation because of changing the mounting method of the engine sprocket.
- (c) The following special tools are newly designed for this motorcycle, and available now. The new special tools are modified to broaden their applicability with less quantity of parts required for service.

| REF. NO. | NEW PART NO. | PART NAME | Q'TY | OLD PART NO. |
|----------|--------------|---------------------------------|------|--------------|
| 1. | 57001-382 | DRIVER | 1 | 57001-380 |
| 2. | 57001-1094 | PISTON RING COMPRESSOR ASSEMBLY | 2 | 57001-921 |
| 3. | 57001-1095 | PISTON RING COMPRESSOR GRIP | 2 | — |
| 4. | 57001-1096 | BELT ($\phi 55 \sim \phi 67$) | 2 | — |
| 5. | 57001-1099 | ROTOR PULLER | 1 | 57001-1016 |
| 6. | 57001-1100 | STEM NUT WRENCH | 1 | 57001-134 |
| 7. | 57001-1111 | VALVE SEAT CUTTER CASE | 1 | — |
| 8. | 57001-1112 | SEPARATE CASE | 1 | — |
| 9. | 57001-1114 | SEAT CUTTER (#2) | 1 | — |
| 10. | 57001-1115 | SEAT CUTTER (#3) | 1 | — |
| 11. | 57001-1119 | OUTSIDE CUTTER (#7) | 1 | — |
| 12. | 57001-1121 | OUTSIDE CUTTER (#9) | 1 | — |
| 13. | 57001-1123 | INSIDE CUTTER (#11) | 1 | — |
| 14. | 57001-1125 | CUTTER HOLDER | 1 | — |
| 15. | 57001-1128 | HANDLE BAR | 1 | — |

①



②

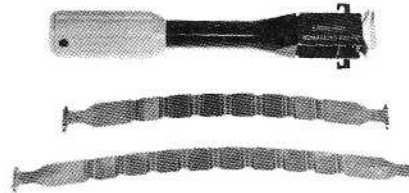

③



④



⑤



⑥

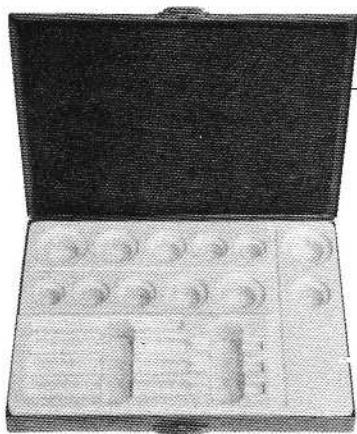

⑦

⑧

⑨



⑩



⑪



⑫



⑬



⑭



⑮



(d) There are selections of inner and outer drivers to choose in the bearing driver set (Part No. : 57001 – 1129), which can be used to press in the ball bearing on the engine and frame of all models. Also, this set can replace the older bearing drivers of the following part numbers.

| | | | |
|--------------------|-----------|-----------|------------|
| Part No. 57001-138 | 57001-283 | 57001-288 | 57001-296 |
| 57001-139 | 57001-284 | 57001-289 | 57001-298 |
| 57001-140 | 57001-286 | 57001-290 | 57001-1053 |
| 57001-282 | 57001-287 | 57001-293 | |

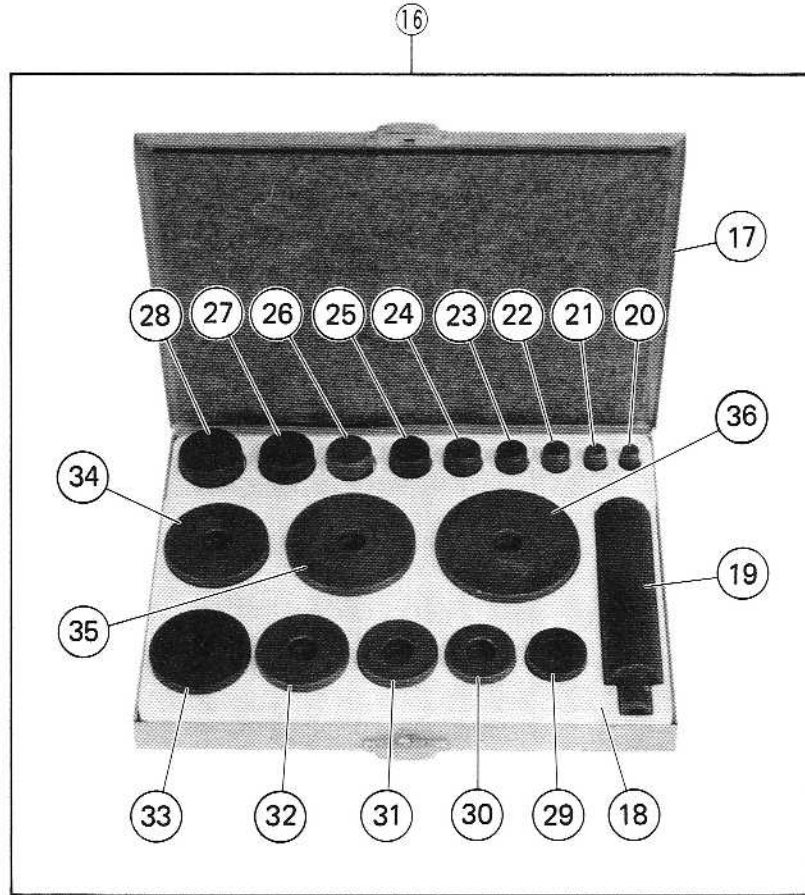

| REF. NO. | PART NO. | PART NAME | REF. NO. | PART NO. | PART NAME |
|----------|------------|---------------------|----------|------------|--------------------------|
| 16 | 57001-1129 | BEARING DRIVER SET | 27 | 57001-1140 | INNER DRIVER (φ30) |
| 17 | 57001-1130 | BEARING DRIVER CASE | 28 | 57001-1141 | INNER DRIVER (φ35) |
| 18 | 57001-1131 | SEPARATE CASE | 29 | 57001-1142 | OUTER DRIVER (φ28 x φ30) |
| 19 | 57001-1132 | DRIVER HOLDER | 30 | 57001-1143 | OUTER DRIVER (φ32 x φ35) |
| 20 | 57001-1133 | INNER DRIVER (φ10) | 31 | 57001-1144 | OUTER DRIVER (φ37 x φ40) |
| 21 | 57001-1134 | INNER DRIVER (φ12) | 32 | 57001-1145 | OUTER DRIVER (φ42 x φ47) |
| 22 | 57001-1135 | INNER DRIVER (φ15) | 33 | 57001-1146 | OUTER DRIVER (φ46 x φ51) |
| 23 | 57001-1136 | INNER DRIVER (φ17) | 34 | 57001-1147 | OUTER DRIVER (φ52 x φ55) |
| 24 | 57001-1137 | INNER DRIVER (φ20) | 35 | 57001-1148 | OUTER DRIVER (φ62 x φ68) |
| 25 | 57001-1138 | INNER DRIVER (φ22) | 36 | 57001-1149 | OUTER DRIVER (φ72 x φ75) |
| 26 | 57001-1139 | INNER DRIVER (φ25) | | | |

Supplement for 1981 Z250-B2

Table of Contents

| | |
|---|-----|
| MODEL IDENTIFICATION | 237 |
| SPECIFICATIONS | |
| SPECIFICATIONS..... | 238 |
| PERIODIC MAINTENANCE CHART | 238 |
| ADJUSTMENT | |
| IGNITION TIMING..... | 238 |
| CAMSHAFT CHAIN | 238 |
| THROTTLE CABLE | 238 |
| REAR SHOCK ABSORBER | 238 |
| SWING ARM | 238 |
| DISASSEMBLY | |
| TORQUE AND LOCKING AGENT..... | 238 |
| CARBURETORS..... | 238 |
| CAMSHAFT CHAIN TENSIONER | 238 |
| CYLINDER BLOCK | 238 |
| PISTON, PISTON RINGS | 238 |
| TRANSMISSION..... | 238 |
| ENGINE SPROCKET | 238 |
| MAINTENANCE | |
| CARBURETORS..... | 238 |
| CAMSHAFT CHAIN, GUIDES, TENSIONER | 238 |
| CYLINDER HEAD, VALVES..... | 238 |
| TRANSMISSION..... | 238 |
| SWING ARM | 238 |
| IGNITION SYSTEM..... | 238 |
| APPENDIX | |
| SPECIAL TOOLS..... | 238 |

Model Identification

Z250-B2 Right Side View

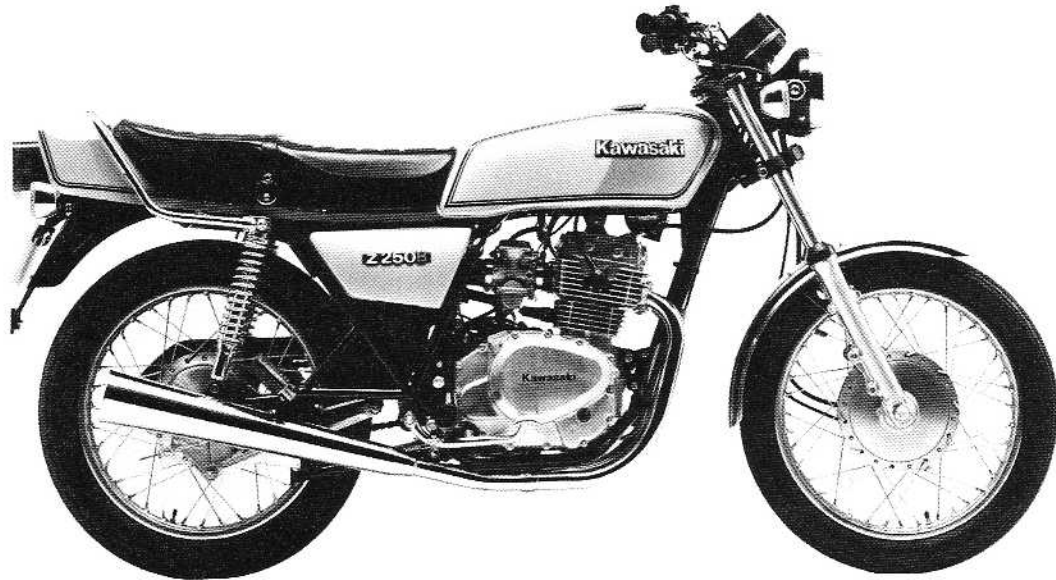

Z250-B2 Left Side View



Specifications

SPECIFICATIONS

The specifications for the 1981 Z250-B2 are shown on Pgs. 214-215.

PERIODIC MAINTENANCE CHART

The Periodic Maintenance Chart for the 1981 Z250-B2 is shown on Pg. 239.

Adjustment

The following five items have been changed, and these adjustment procedures are the same as those for the 1981 Z250-A3. Refer to the supplement for the 1981 Z250-A3.

- IGNITION TIMING (See Pg. 217)
- CAMSHAFT CHAIN (See Pg. 217)
- THROTTLE CABLE (See Pg. 217)
- REAR SHOCK ABSORBER (See Pg.217)
- LUBRICATION (See Pg. 218)

Disassembly

TORQUE AND LOCKING AGENT

Tighten the engine parts in accordance with the torque and locking agent table on Pgs. 218 and 195, and tighten the frame parts in accordance with the torque and locking agent table on Pg. 196.

The following six items have been changed, and these disassembly and assembly procedures are the same as those for the 1981 Z250-A3. Refer to the supplement for the 1981 Z250-A3.

- CARBURETORS (See Pg. 218)
- CAMSHAFT CHAIN TENSIONER (See Pg. 223)
- CYLINDER BLOCK (See Pg. 224)
- PISTON, PISTON RINGS (See Pg. 224)
- TRANSMISSION (See Pg. 225)
- ENGINE SPROCKET (See Pg. 225)

Maintenance

The following six items have been changed, and these maintenance procedures are the same as those for the 1981 Z250-A3. Refer to the supplement for the 1981 Z250-A3.

- CARBURETORS (See Pg. 230)
- CAMSHAFT CHAIN, GUIDES, TENTIONER (See Pg. 230)
- CYLINDER HEAD, VALVES (See Pg. 230)
- TRANSMISSION (See Pg. 232)
- SWING ARM (See Pg. 232)

- IGNITION SYSTEM (See Pg. 232)

Appendix

The following item has been changed, and this is the same as it for the 1981 Z250-A3. Refer to the supplement for the 1981 Z250-A3.

- SPECIAL TOOLS (See Pg. 233)

PERIODIC MAINTENANCE CHART (Z250-B2)

The maintenance and adjustments must be done in accordance with this chart to keep the motorcycle in good running condition. The initial maintenance is vitally important and must not be neglected.

| OPERATION | FREQUENCY | ODOMETER READING* | | | | | | | See Page |
|--|--------------|-------------------|----------|-----------|-----------|-----------|-----------|-----------|----------|
| | | 800 km | 5,000 km | 10,000 km | 15,000 km | 20,000 km | 25,000 km | 30,000 km | |
| Battery electrolyte level – check † | Every month | • | • | • | • | • | • | • | 156 |
| Brake – check † | | • | • | • | • | • | • | • | 192 |
| Brake light switch – check † | | • | • | • | • | • | • | • | 26 |
| Brake wear – check † | | | • | • | • | • | • | • | 209 |
| Clutch – adjust | | • | • | • | • | • | • | • | 20 |
| Carburetor operation – check † | | • | • | • | • | • | • | • | 18 |
| Throttle grip – check † | | • | • | • | • | • | • | • | 238 |
| Steering play – check † | | • | • | • | • | • | • | • | 26 |
| Spoke tightness and rim runout – check † | | • | • | • | • | • | • | • | 207 |
| Drive chain wear – check † | | | • | • | • | • | • | • | 144 |
| Front fork – clean | | | • | • | • | • | • | • | 151 |
| Nuts, bolts, fasteners – check † | | • | | • | | • | | • | 238 |
| Spark plug – clean and gap † | | • | • | • | • | • | • | • | 12 |
| Ignition timing – check † | | • | • | • | • | • | • | • | 238 |
| Valve clearance – check † | | • | • | • | • | • | • | • | 16 |
| Air cleaner element – clean | | | • | | • | | • | | 115 |
| Air cleaner element – replace | 5 cleanings | | | • | | • | | • | 115 |
| Fuel system – clean | | | | • | | • | | • | 22 |
| Tire tread wear – check † | | | • | • | • | • | • | • | 140 |
| Engine oil – change | year | • | • | • | • | • | • | • | 22 |
| Oil filter – replace | | • | | • | | • | | • | 22 |
| General lubrication – perform | | | • | • | • | • | • | • | 195 |
| Front fork oil – change | | | | • | | • | | • | 152 |
| Timing advancer – lubricate | | | | • | | • | | • | 162 |
| Swing arm – lubricate | | | | • | | • | | • | 238 |
| Wheel bearing – lubricate | 2 years | | | | | • | | | 143 |
| Speedometer gear – lubricate | 2 years | | | | | • | | | 209 |
| Brake camshaft – lubricate | 2 years | | | | | • | | | 210 |
| Steering stem bearing – lubricate | 2 years | | | | | • | | | 150 |
| Brake cable – replace | 2 years | | | | | | | | 198 |
| Fuel hose – replace | 4 years | | | | | | | | — |
| Drive chain – lubricate | Every 300 km | | | | | | | | 144 |
| Drive chain slack – check † | Every 800 km | | | | | | | | 24 |

* For higher odometer readings, repeat at the frequency interval established here.

† Replace, add, adjust or torque if necessary.

Supplement for 1981 KZ305-A1

NOTE: The maintenance and repair procedures for the KZ305A are newly included in this section. Unless otherwise noted, procedures for the 1981 KZ305-A1 are the same as those for their standard model 1979 Z250-A1.

Table of Contents

| | |
|--|-----|
| MODEL IDENTIFICATION..... | 241 |
| SPECIFICATIONS | |
| SPECIFICATIONS..... | 242 |
| PERIODIC MAINTENANCE CHART..... | 244 |
| ADJUSTMENT | |
| IGNITION TIMING..... | 245 |
| CAMSHAFT CHAIN..... | 245 |
| THROTTLE CABLE..... | 245 |
| REAR SHOCK ABSORBER..... | 245 |
| LUBRICATION..... | 245 |
| SPARK PLUGS..... | 245 |
| CARBURETORS..... | 245 |
| FUEL SYSTEM..... | 245 |
| BRAKES..... | 245 |
| WHEEL BALANCE..... | 245 |
| HEADLIGHT..... | 246 |
| DISASSEMBLY | |
| TORQUE AND LOCKING AGENT..... | 246 |
| CARBURETORS..... | 246 |
| CAMSHAFT CHAIN TENSIONER..... | 246 |
| PISTON, PISTON RINGS..... | 246 |
| TRANSMISSION..... | 246 |
| ENGINE SPROCKET..... | 246 |
| CYLINDER HEAD COVER, ROCKER ARM..... | 246 |
| CLUTCH..... | 246 |
| FRONT WHEEL..... | 247 |
| FRONT BRAKE..... | 250 |
| REAR WHEEL, BRAKE, COUPLING..... | 250 |
| RIM..... | 250 |
| SPOKES..... | 250 |
| MAINTENANCE | |
| ROCKER ARMS, SHAFTS..... | 250 |
| CAMSHAFT..... | 250 |
| CAMSHAFT CHAIN, GUIDES, TENSIONER..... | 250 |
| CYLINDER HEAD, VALVES..... | 250 |
| SWING ARM..... | 250 |
| IGNITION SYSTEM..... | 250 |
| CARBURETORS..... | 250 |
| CYLINDER BLOCK, PISTONS..... | 251 |
| TRANSMISSION..... | 251 |
| WHEELS..... | 251 |
| SPROCKETS..... | 253 |
| BRAKES..... | 254 |
| SPARK PLUGS..... | 254 |
| APPENDIX | |
| SPECIAL TOOLS..... | 254 |
| WIRING DIAGRAM..... | 254 |

Model Identification

KZ305-A1 Right Side View

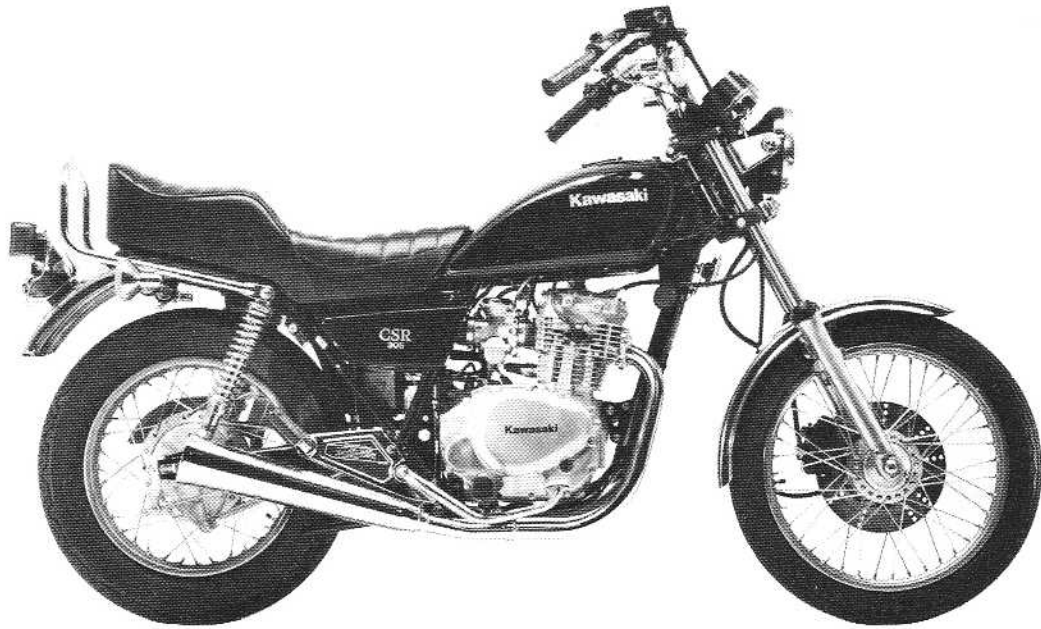

KZ305-A1 Left Side View



Specifications

SPECIFICATIONS

| | KZ305-A1 (US model) | KZ305-C1 (Canadian model) | |
|------------------------|--|------------------------------|---|
| Dimensions | | | |
| Overall length | 2,030 mm | * | |
| Overall width | 815 mm | * | |
| Overall height | 1,150 mm | * | |
| Wheelbase | 1,355 mm | * | |
| Road clearance | 150 mm | * | |
| Dry weight | 152 kg | 153 kg | |
| Fuel tank capacity | 10.5 ℓ | * | |
| Performance | | | |
| Climbing ability | 27° | * | |
| Braking distance | 12.5 m from 50 kph | * | |
| Minimum turning radius | 2.3 m | * | |
| Engine | | | |
| Type | SHOC, 2-cylinder, 4-stroke, air-cooled | * | |
| Bore and stroke | 61.0 x 52.4 mm | * | |
| Displacement | 306 cc | * | |
| Compression ratio | 9.5 | * | |
| Maximum horsepower | 30 HP @9,000 rpm | * | |
| Maximum torque | 2.5 kg-m @7,000 rpm | * | |
| Valve timing | | | |
| Inlet | Open | 21° BTDC | * |
| | Close | 59° ABDC | * |
| | Duration | 260° | * |
| Exhaust | Open | 61° BBDC | * |
| | Close | 19° ATDC | * |
| | Duration | 260° | * |
| Carburetors | Keihin CV32 x 2 | * | |
| Lubrication system | Forced lubrication (wet sump) | * | |
| Engine oil | SE class SAE 10W40, 10W50 20W40, 20W50 | * | |
| Engine oil capacity | 1.8ℓ, 1.5ℓ (without filter change) | * | |
| Starting system | Electric Starter | * | |
| Ignition system | Battery and coil | * | |
| Ignition timing | From 10° BTDC @1,250 rpm to 40° BTDC @2,500 rpm | * | |
| Spark plugs | NGK D9EA | NGK DR8ES or ND X 24ESR-U | |
| Transmission | | | |
| Type | 6-speed, constant mesh, return shift | * | |
| Clutch | Wet, multi disc | * | |
| Gear ratio: 1st | 2.60 (39/15) | * | |
| 2nd | 1.79 (34/19) | * | |
| 3rd | 1.41 (31/22) | * | |

| | KZ305-A1 (US model) | KZ305-C1 (Canadian model) |
|-------------------------------------|---|---------------------------|
| 4th | 1.16 (29/25) | * |
| 5th | 1.00 (27/27) | * |
| 6th | 0.89 (25/28) | * |
| Primary reduction ratio | 3.74 (71/19) | * |
| Final reduction ratio | 2.20 (33/15) | * |
| Overall drive ratio | 7.34 (@Top gear) | * |
| Electrical Equipment | | |
| Alternator Rated Output | 13.5 amp. @8,000 rpm, 14V | * |
| Regulator/Rectifier | Shindengen SH221-12 | * |
| Ignition coil | Toyo denso ZC003-12V | * |
| Battery | Yuasa YB10L-A2 (12V10AH) | * |
| Starter | Mitsuba SM-725-1 | * |
| Headlight type | Sealed beam | * |
| Headlight | 12V 50/35W | * |
| Tail/Brake light | 12V 8/27W | * |
| Turn signal lights | 12V23W | * |
| Meter lights | 12V3.4W | * |
| Indicator lights | 12V3.4W | * |
| Horn | 12V2A | * |
| Frame | | |
| Type | Tubular, single cradle | * |
| Steering angle | 40° to either side | * |
| Castor | 28.5° | * |
| Trail | 106 mm | * |
| Tire size | Front 3.00S-18 4PR | * |
| | Rear 120/90-16 63S | * |
| Suspension | Front Telescopic fork | * |
| | Rear Swing arm | * |
| Wheel travel | Front 150 mm | * |
| | Rear 105 mm | * |
| Front fork oil capacity (each fork) | 150 cc | * |
| Front fork oil type | SAE 5W 20 | * |
| Brakes | | |
| Type | Front Single disc brake | * |
| | Rear Internal expansion, leading-trailing | * |
| Effective disc diameter | Front 226 mm | * |
| Inside diameter and Width | Rear 160 x 30 mm | * |

Specification subject to change without notice, and may not apply to every country.

PERIODIC MAINTENANCE CHART (KZ305-A1)

The maintenance and adjustments must be done in accordance with this chart to keep the motorcycle in good running condition. The initial maintenance is vitally important and must not be neglected.

| OPERATION | FREQUENCY | ODOMETER READING* | | | | | | | See Page |
|---|--------------|-----------------------|--------|----------|-----------|-----------|-----------|-----------|----------|
| | | Whichever comes first | 800 km | 5,000 km | 10,000 km | 15,000 km | 20,000 km | 25,000 km | |
| | Every | | | | | | | | |
| Battery electrolyte level — check † | month | • | • | • | • | • | • | • | 156 |
| Brake — check † | | • | • | • | • | • | • | • | 245 |
| Brake light switch — check † | | • | • | • | • | • | • | • | 26 |
| Brake wear — check † | | | • | • | • | • | • | • | 254 |
| Brake fluid level — check † | month | • | • | • | • | • | • | • | 254 |
| Brake fluid — change | year | | | • | • | | | • | 254 |
| Clutch — adjust | | • | • | • | • | • | • | • | 20 |
| Carburetor operation — check † | | • | • | • | • | • | • | • | 245 |
| Throttle grip — check † | | • | • | • | • | • | • | • | 245 |
| Steering play — check † | | • | • | • | • | • | • | • | 26 |
| Spoke tightness and rim runout — check | | • | • | • | • | • | • | • | 252 |
| Drive chain wear — check † | | | • | • | • | • | • | • | 144 |
| Front fork — clean | | | • | • | • | • | • | • | 151 |
| Nuts, Bolts, Fasteners — check † | | • | | • | | • | | • | 246 |
| Spark plug — clean and gap † | | • | • | • | • | • | • | • | 245 |
| Ignition timing — check † | | • | • | • | • | • | • | • | 245 |
| Valve clearance — check † | | • | • | • | • | • | • | • | 16 |
| Air cleaner element — clean | | | • | • | | • | | | 115 |
| Air cleaner element — replace | 5 cleanings | | | • | | • | | • | 115 |
| Fuel system — clean | | | | • | | • | | • | 245 |
| Tire tread wear — check † | | | • | • | • | • | • | • | 251 |
| Engine oil — change | year | • | • | • | • | • | • | • | 22 |
| Oil filter — replace | | • | | • | | • | | • | 22 |
| General lubrication — perform | | | • | • | • | • | • | • | 245 |
| Front fork oil — change | | | | • | | • | | • | 152 |
| Timing advancer — lubricate | | | | • | | • | | • | 162 |
| Swing arm — lubricate | | | | • | | • | | • | 245 |
| Wheel bearing — lubricate | 2 years | | | | | • | | | 253 |
| Speedometer gear — lubricate | 2 years | | | | | • | | | 253 |
| Brake camshaft — lubricate | 2 years | | | | | • | | | 254 |
| Steering stem bearing — lubricate | 2 years | | | | | • | | | 150 |
| Mastercylinder cup and dust seal — replace | 2 years | | | | | | | | 254 |
| Caliper piston seal and dust seal — replace | 2 years | | | | | | | | 254 |
| Brake hose — replace | 4 years | | | | | | | | 254 |
| Fuel hose — replace | 4 years | | | | | | | | — |
| Drive chain — lubricate | Every 300 km | | | | | | | | 144 |
| Drive chain slack — check † | Every 800 km | | | | | | | | 24 |

* For higher odometer readings, repeat at the frequency interval established here.

† Replace, add, adjust or torque if necessary.

Adjustment

The adjustment procedures for the following five items are the same as those for the 1981 Z250-A3. Refer to the supplement for the 1981 Z250-A3.

- IGNITION TIMING (See Pg. 217)
- CAMSHAFT CHAIN (See Pg. 217)
- THROTTLE CABLE (See Pg. 217)
- REAR SHOCK ABSORBER (See Pg. 217)
- LUBRICATION (See Pg. 218)

SPARK PLUGS

The adjustment procedures are the same as those for the 1979 Z250-A1 with the following exception. Refer to Pg. 13.

Table N24 Spark Plugs

| | |
|-------------------|------------------------|
| Type | NGK D9EA |
| Gap | 0.6 – 0.7 mm |
| Tightening Torque | 2.0 kg-m (14.5 ft-lbs) |

CARBURETORS

The procedures are the same as those for the 1979 Z250-A1 with the following exception. Refer to Pgs. 18 – 20.

Idling Adjustment

- Start the engine, and warm it up thoroughly.
- Adjust the idle speed to 1,200 ~ 1,300 rpm by turning the idle adjusting screw.

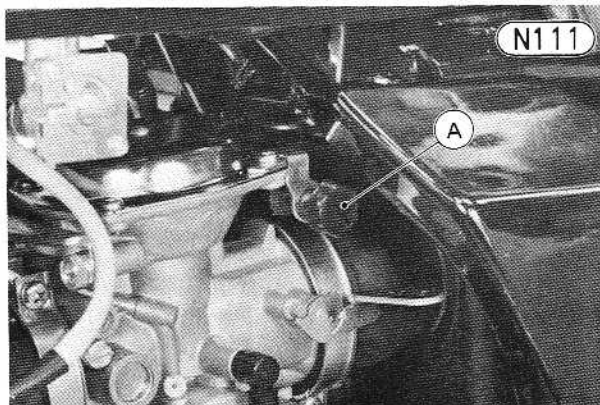

A. Idle Adjusting Screw

- Open and close the throttle a few times to make sure that the idle speed does not change. Readjust if necessary.

NOTE: With the engine idle, turn the handlebar to either side. If handlebar movement changes idle speed,

the throttle cable may be improperly adjusted or incorrectly routed, or it may be damaged.

WARNING Operation with improperly adjusted, incorrectly routed, or damaged cable could result in an unsafe riding condition.

FUEL SYSTEM

Water anywhere in the fuel system can cause starting difficulty, poor running, and lack of power. Clean out the fuel system as follows:

- WARNING**
1. Clean the fuel system in a well-ventilated area, and take ample care that there are no sparks or flame anywhere near the working area.
 2. Never clean out the fuel system when the engine is still warm.
 3. Wipe any fuel off the engine before starting it.

- Run the ends of the overflow tubes into a suitable container, and turn the tap to the “RES” position.
- Loosen the drain screws to drain the tank and carburetor float bowls through the overflow tubes until only fuel comes out, and tighten the drain screws. Turn the tap to the “OFF” position.

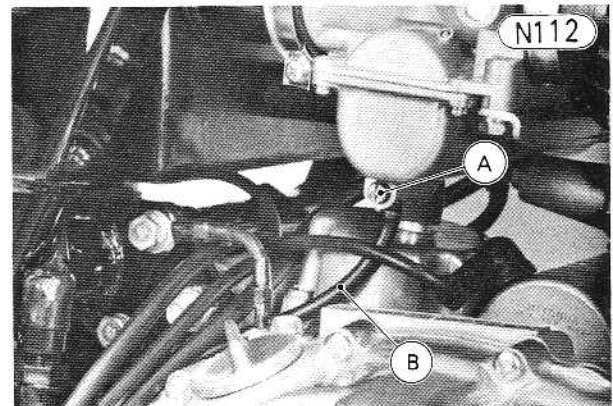

A. Drain Screw B. Overflow Tube

- If any dirt comes out, disassembly and clean the following parts.
 - Fuel Tank
 - Fuel Tap
 - Carburetors (Pg. 246)

BRAKES

This motorcycle has the front disc and rear drum brake system. Adjust the front and rear brakes referring to Pg. 25 (front brake) and Pg. 193 (rear brake).

WHEEL BALANCE

Balance the wheels according to the procedures shown on Pg. 194.

HEADLIGHT

The headlight beam is adjustable both horizontally and vertically. If not properly adjusted horizontally, the beam will point to one side rather than straight ahead. If adjusted too low vertically, neither low nor high beam will illuminate the road for enough ahead. If adjusted too high vertically, high beam will fail to illuminate the road close ahead, and low beam will blind oncoming drivers.

Horizontal Adjustment (Except European Models)

- Turn the adjusting screw on the headlight rim in or out until the beam points straight ahead. Turning the adjusting screw clockwise makes the headlight beam point to the left.

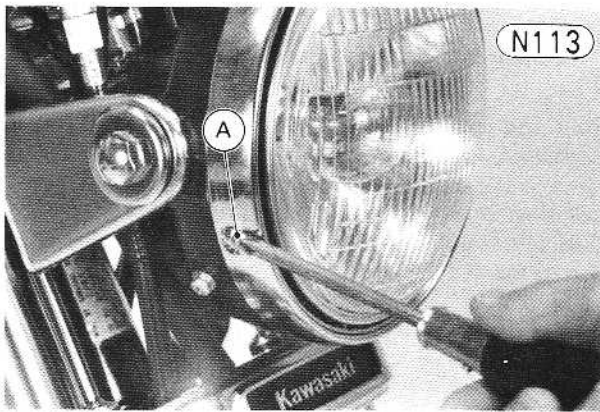

A. Adjusting Screw

Vertical Adjustment

Refer to Pg. 28.

Disassembly

TORQUE AND LOCKING AGENT

Tighten the engine parts in accordance with the torque and locking agent table on Pgs. 218 and 195, and tight the frame parts in accordance with the torque and locking agent table on Pg. 196 and table N 25 on Pg. 250.

CARBURETORS

The procedures for the US model are the same as those for the 1981 Z250-A3 with the following exceptions. See Pg. 218 – 223.

Carburetor Disassembly and Assembly

1. To remove the pilot screw, first punch and pry off the plug with an awl or other suitable tools. Turn in the pilot screw and count the number of turns until it seats fully but not tightly, and then remove it with its O-ring, flat washer, and spring. This is to set the pilot screw to its original position when assembling.
2. Install the air screw as follows:
 - Turn in the pilot screw fully but not tightly, and then back it out the same number of turns counted during disassembly.
 - Install a new plug in the pilot screw hole, and apply a small amount of a bonding agent to the circumference of the plug to fix the plug.

Plug Installation

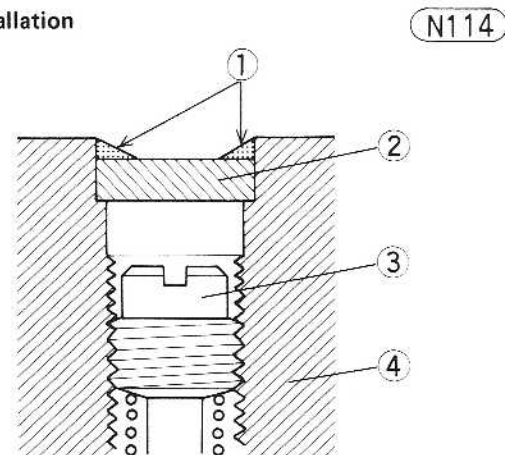

1. Apply a bonding agent.
2. Pilot Screw Plug
3. Pilot Screw
4. Carburetor Body

WARNING Do not apply too much bond on the plug to keep the pilot screw itself from being fixed.

The procedures for the following four items are the same as those for the 1981 Z250-A3. Refer to the supplement for the 1981 Z250-A3.

- CAMSHAFT CHAIN TENSIONER (See Pg. 223)
- PISTON, PISTON RINGS (See Pg. 224)
- TRANSMISSION (See Pg. 225)
- ENGINE SPROCKET (See Pg. 225)

The procedures for the following two items are the same as those for the 1980 Z250-A2. Refer to the supplement for the 1980 Z250-A2.

- CYLINDER HEAD COVER, ROCKER ARM (See Pg. 184)
- CLUTCH (See Pg. 184)

FRONT WHEEL

Removal:

- Put the motorcycle up on its center stand.
- Disconnect the lower end of the speedometer cable with pliers.

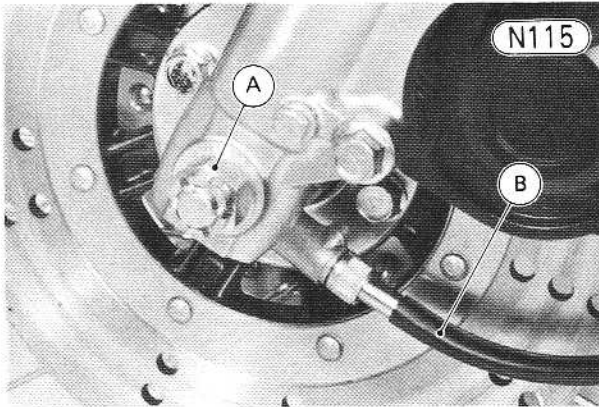

A. Axle Nut B. Speedometer Cable

- Remove the front axle cotter pin, nut, and washer.
- Use a jack under the engine to lift the front of the motorcycle.
- Holding the front wheel to facilitate axle removal, pull out the axle, and then remove the wheel from the motorcycle.

WARNING Do not lay the wheel down on the brake disc. This can damage or warp the disc. Place blocks under the wheel so the disc does not touch the ground.

- Insert a wood wedge (4 ~ 5 mm thick) between the disc brake pads. This prevents the pads from being moved out of their proper position, should the brake lever be squeezed accidentally.

Installation:

- Remove the wedge from between the disc brake pads.
- Check that the speedometer gear housing is properly fitted on the front hub, and check that the collar is on the right side of the hub.
- Hold the front wheel in its place between the front fork tubes, and insert the axle from the right.
- Put the axle nut on the other end but do not tighten it.
- Set the speedometer gear housing so that it points rear, and fit the housing stops to the fork leg stop.

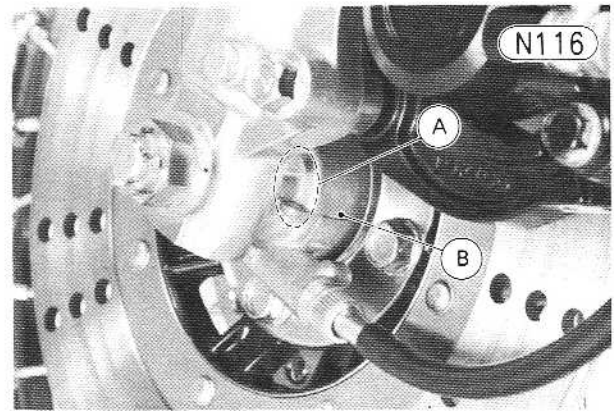

A. Fork Leg Stop B. Speedometer Gear Housing

- Tighten the axle nut to 6.0 kg-m (43 ft-lbs) of torque.

WARNING If the axle nut is not securely tightened, an unsafe riding condition could result.

- Insert a new cotter pin through the axle nut and axle, and spread its ends.
- Insert the speedometer inner cable into the housing while turning the wheel so that the slot in the end of the cable will seat in the tongue of the speedometer pinion. Tighten the cable nut with pliers.

WARNING The front brake lever must be pumped to move the brake pads into operating position. If this is not done, the first few applications of the brake may be ineffective and an unsafe riding condition could result.

Speedometer Gear Housing Disassembly:

- Pull the speedometer gear housing (4) off the wheel hub.
- Put the speedometer gear housing into a suitable container filled with engine oil, and heat the container so that the temperature of the oil raises to 180~200°C.
- Being careful not to suffer a burn, pick up the speedometer gear housing and remove the grease seal using a hook.

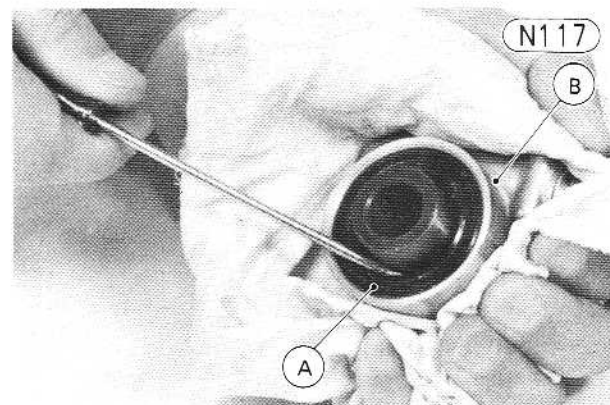

A. Grease Seal B. Gear Housing

Front Hub

N118

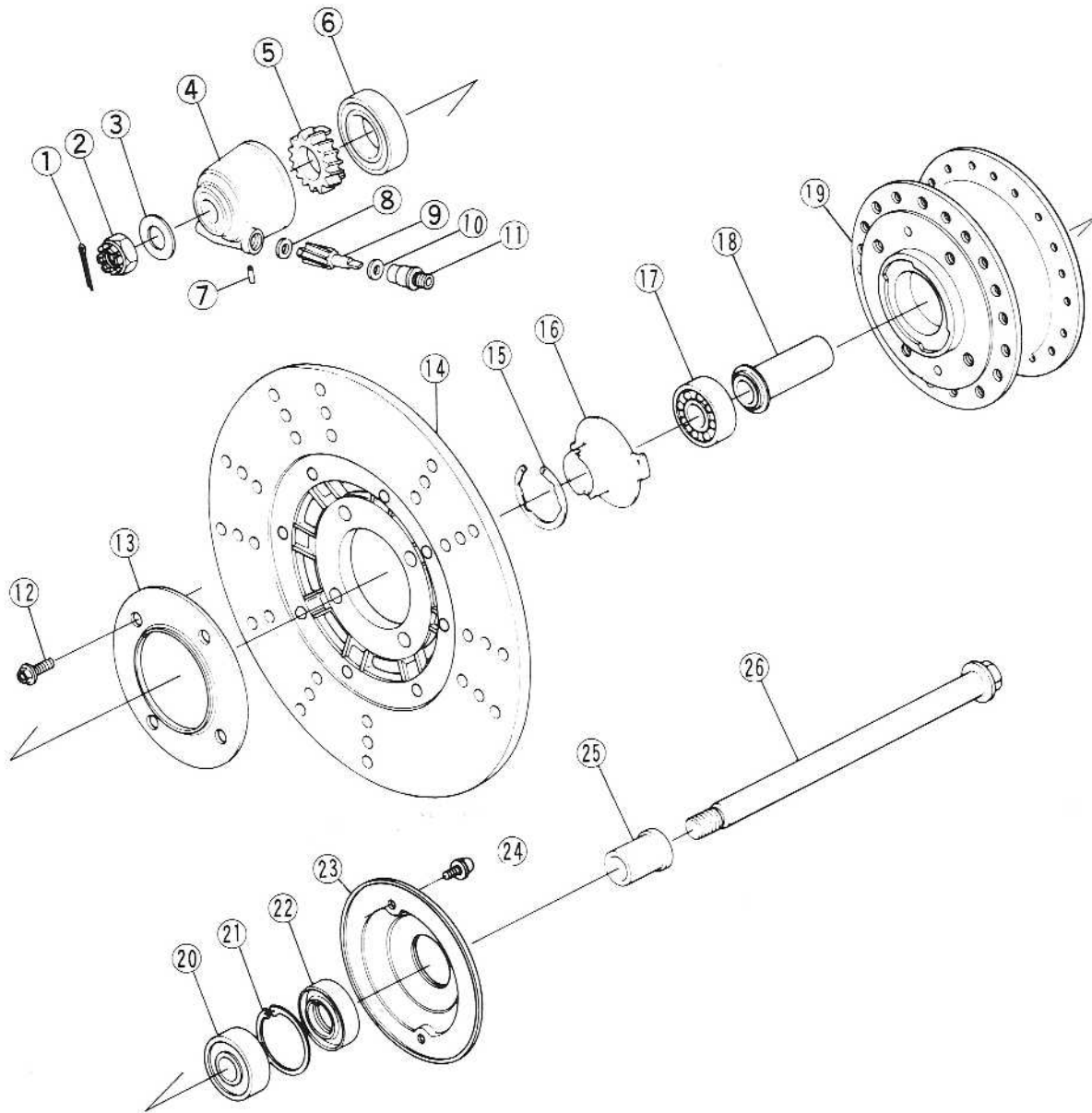

- 1. Cotter Pin
- 2. Axle Nut
- 3. Washer
- 4. Speedometer Gear Housing
- 5. Speedometer Gear
- 6. Grease Seal
- 7. Pin
- 8. Washer
- 9. Speedometer Pinion

- 10. Washer
- 11. Bushing
- 12. Bolt
- 13. Plate
- 14. Disc
- 15. Circlip
- 16. Speedometer Gear Drive
- 17. Ball Bearing
- 18. Distance Collar

- 19. Front Hub
- 20. Ball bearing
- 21. Circlip
- 22. Grease Seal
- 23. Cap
- 24. Screw
- 25. Collar
- 26. Front Axle

- Pull out the speedometer gear ⑤.
 - If it is necessary to remove the speedometer cable bushing ⑪ or speedometer pinion ⑨, first drill the housing through the pin ⑦ using a 1 mm drill bit. Drill the housing from the gear side using a 2 mm drill bit.
 - Using a suitable tool, tap out the pin, and then pull out the speedometer cable bushing and pinion.
- NOTE:** It is recommended that the speedometer gear housing is replaced as an assembly rather than repairing the components.

Assembly Notes:

1. Replace the grease seal with a new one. Apply a little grease to the seal. Install it using a suitable driver so that the face of the seal is level with the surface of the housing.
2. After inserting a new pin, punch the housing hole to secure the pin in place.
3. Regrease the speedometer gear.
4. Install the speedometer gear housing so that it fits in the speedometer gear drive notches.

**Front Hub Disassembly
(including disc removal):**

- Pull the speedometer gear housing ④ and collar ⑫ off the front hub.
- Remove the screws ⑭ (2) with washers, and take the cap ⑮ off the right side of the hub.
- Using a hook, pull out the grease seal ⑲ and remove the circlip ⑲.

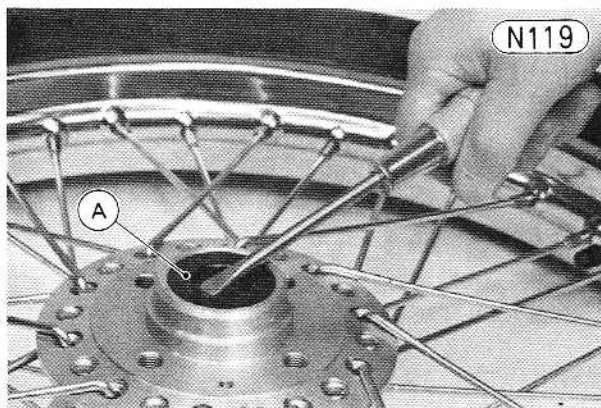

A. Grease Seal

- Remove the bolts ⑫ (4), plate ⑬, and disc ⑭ off the left side.
- Remove the circlip ⑮ and speedometer gear drive ⑯.
- Insert a metal rod into the hub from the left side, and remove the bearing ⑰ on the right side by tapping evenly around the bearing inner race. The distance collar ⑱ will come out with the bearing.

Bearing Removal

N120

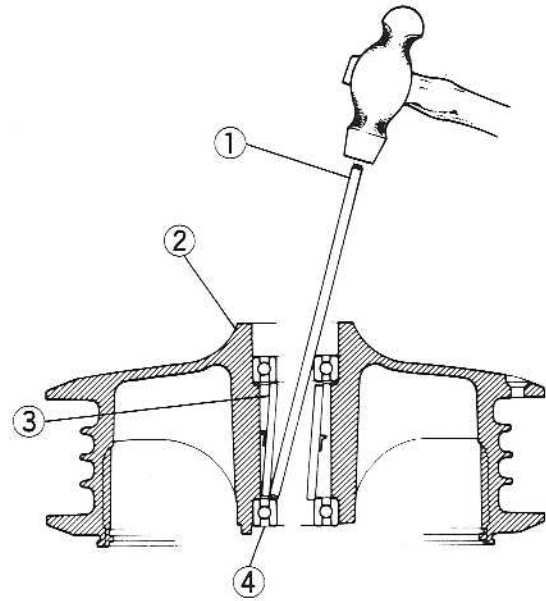

1. Metal Rod
2. Front Hub
3. Distance Collar
4. Ball Bearing

- Insert the metal rod into the hub from the right side, and remove the other bearing ⑰ by tapping evenly around the bearing inner race.

Front Hub Assembly:

- Inspect the bearings and replace if necessary (Pg. 143).
- Lubricate the ball bearings (Pg. 143).
- Before installing the wheel bearings, blow any dirt or foreign particles out of the hub with compressed air to prevent contamination of the bearings.
- Install the right side ball bearing using the outer driver, inner driver, and the driver holder (special tools). Press the bearing until it stops at the bottom of the hole.

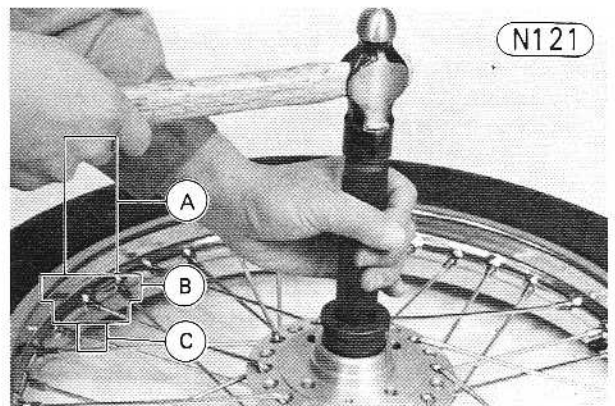

A. Driver Holder (57001-1132)
B. Outer Driver (57001-1145; φ 42 x φ 47)
C. Inner Driver (57001-1135; φ 15)

- Put the distance collar into the hub.
- Install the left side ball bearing using the same special tools, and install the circlip.
- Install a new grease seal using a outer driver, inner driver and bearing driver holder (special tools: P/N 57001-1145, 1138, 1132). Press the seal so that the face of the seal is level with the surface of the front hub.
- Install the cap using the screws (2).
- Install the speedometer gear drive fitting it in the hub notches, and install the circlip.
- Place the disc on the hub, and install the plate in place. The plate must be installed with the protruding side facing out.

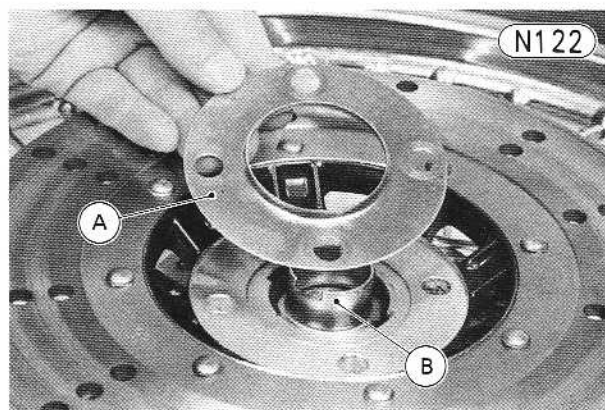

A. Plate

B. Speedometer Gear Drive

- Tighten the disc mounting bolts (4) to 3.0 kg-m (22 ft-lbs) of torque.
- After installing the disc, check the disc runout (Pg. 150).
- Install the speedometer gear housing so that it fits in the speedometer gear drive notches.
- Install the collar on the right side of the hub.
- Completely clean off any grease that has gotten on either side of the disc with a high flash-point solvent. Do not use one which will leave an oily residue.

FRONT BRAKE

The procedures are the same as those for the 1981 Z250-A3 with the following exception. See Pg. 227.

1. Tighten the parts related to disc brake to the torque shown on Table N26.

Table N25 Carburetor Specifications

| Type | Main Jet | | Air Jet | | | Pilot Jet | Pilot Screw | Service Fuel Level |
|------|----------|-----------|---------|--------------|------------------------|-----------|---|--------------------|
| | Primary | Secondary | Pilot | Primary Main | Secondary Main | | | |
| CV32 | #62 | #85 | #120 | #150 | Left #70 Right # 50 | #35 | 2 ¹ / ₄ turns out | 1.5 – 3.5 mm |

Table N26 Disc Brake Torque

| | | |
|--------------------------------|-----------|-------------|
| Bleed valve | 0.80 kg-m | 69 in-lbs |
| Brake lever pivot bolt | 0.30 kg-m | 26 in-lbs |
| Brake lever pivot bolt locknut | 0.60 kg-m | 52 in-lbs |
| Caliper holder shaft bolts | 1.80 kg-m | 13.0 ft-lbs |
| *Caliper mounting bolts | 4.0 kg-m | 29 ft-lbs |
| Disc mounting bolts | 3.0 kg-m | 22 ft-lbs |
| Fitting (banjo) bolts | 3.0 kg-m | 22 ft-lbs |
| *Master cylinder clamp bolts | 0.90 kg-m | 78 in-lbs |

* : Retorque these parts according to Periodic Maintenance Chart (Pg. 244)

The procedures for the following three items are the same as those for the 1980 Z250-B1. Refer to the supplement for the 1980 Z250-B1.

○ **REAR WHEEL, BRAKE, COUPLING**

(See Pg. 202)

○ **RIM** (See Pg. 205)

○ **SPOKES** (See Pg. 206)

Maintenance

The following two items are the same as those for the 1980 Z250-A2. Refer to the supplement for the 1980 Z250-A2.

○ **ROCKER ARMS, SHAFTS** (See Pg. 185)

○ **CAMSHAFT** (See Pg. 185)

The following four items are the same as those for the 1981 Z250-A3. Refer to the supplement for the 1981 Z250-A3.

○ **CAMSHAFT CHAIN, GUIDES, TENSIONER**

(See Pg. 230)

○ **CYLINDER HEAD, VALVES** (See Pg. 230)

○ **SWING ARM** (See Pg. 232)

○ **IGNITION SYSTEM** (See Pg. 232)

CARBURETORS

Refer to Pgs. 115~119, noting the following.

1. Carburetor specifications are shown on table N 25.

CYLINDER BLOCK, PISTONS

The procedures are the same as those for the 1979 Z250-A1 with the following exceptions. Refer to Pg. 127.

Table N27 Cylinder Inside Diameter

| | |
|--------------|--|
| Usable Range | Should be less than 61.10 mm and 0.05 mm difference between any two measurements |
|--------------|--|

Table N28 Piston Diameter

| | |
|---------------|----------|
| Service Limit | 60.82 mm |
|---------------|----------|

Table N29 Piston Ring/Groove Clearance

| | | |
|---------------|---------|---------|
| Service Limit | Top | 2nd |
| | 0.18 mm | 0.16 mm |

Table N30 Piston Ring Thickness

| | | |
|---------------|---------|---------|
| Service Limit | Top | 2nd |
| | 1.09 mm | 1.10 mm |

Table N31 Piston Ring Groove Width

| | | | |
|---------------|---------|---------|---------|
| Service Limit | Top | 2nd | Oil |
| | 1.32 mm | 1.31 mm | 2.61 mm |

Table N32 Piston Ring End Gap

| | | |
|---------------|--------|-----|
| Service Limit | Top | 2nd |
| | 0.7 mm | |

TRANSMISSION

Refer to Pgs. 133 – 135, noting the following.

External shift mechanism inspection

Table N33 Shift Arm Spring, Shift Positioner Spring Free Length

| | |
|--------------------|---------------|
| | Service Limit |
| Shift Arm | 19 mm |
| Neutral Positioner | 24 mm |
| Gear Positioner | 24 mm |

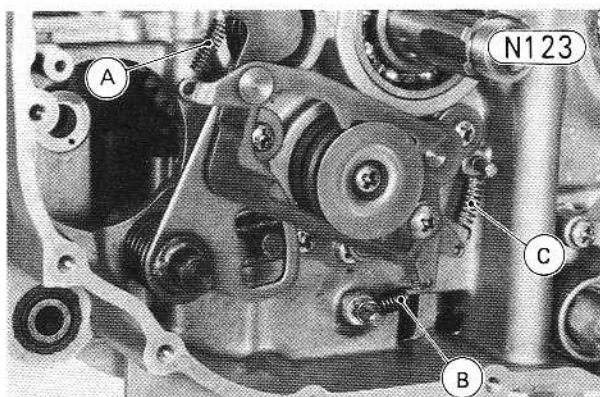

A. Shift Arm Spring B. Neutral Positioner Spring
C. Gear Positioner Spring

WHEELS

The following sections, Pgs. 251 – 253, cover the tires, rims, spokes, axles, wheel bearings, grease seals, and rear wheel coupling. For the brakes, see Pg. 253.

Tires

Table N34 Tires, Air Pressure (measured when cold)

| | Air Pressure | Size | Make, Type |
|-------|---|------------------|-----------------|
| Front | 1.75 kg/cm ² (25 psi, 175kPa) | 3.00S-18 4PR | Dunlop F8 |
| Rear | Up to 97.5 kg | 120/90-16 63S | Dunlop K 327 |
| | 97.5 ~ 155 kg | | |

Tire wear, damage

Tires must not be used if they are getting bald, or if they are cut or otherwise damaged. As the tire tread wears down, the tire becomes more susceptible to puncture and failure. 90% of tire failures occur during the last 10% of tire life.

Visually inspect the tire for cracks and cuts, replacing the tire in case of bad damage. Remove any imbedded stones or other foreign particles from the tread. Swelling or high spots indicate internal damage, requiring tire replacement unless the damage to the fabric is very minor.

Measure the depth of the tread with a depth gauge, and replace the tire if the tread depth is less than the service limit.

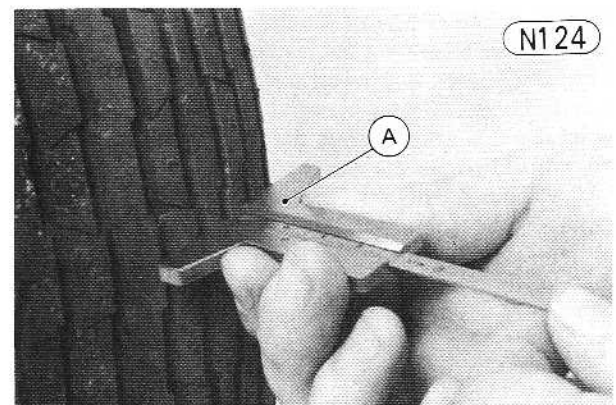

A. Depth Gauge

Table N35 Tire Tread Depth

| Service Limit | | |
|---------------|------------------|------|
| Front | 1 mm | |
| Rear | under 110 kph | 2 mm |
| | over 110 kph | 3 mm |

Rim, Spokes

The rim of each wheel is made of steel and is connected to the hub by the spokes. A rim band around the outside center of the rim keeps the tube from coming into direct contact with the spoke nipples.

Since the spokes must withstand repeated stress, it is important to take sufficient care that the spokes are not allowed to loosen and that they are tightened evenly. Loose or unevenly tightened spokes cause the rim to warp, increase the possibility of spoke breakage, and hasten nipple and spoke metal fatigue.

NOTE: The rim size shown in Table N36 is the outer width and diameter, both in inches.

Table N36 Rim Size

| | |
|-------|-----------|
| Front | 1.60 x 18 |
| Rear | 2.15 x 16 |

Spoke breakage

If any spoke breaks, it should be replaced immediately. A missing spoke places an additional load on the other spokes, which will eventually cause other spokes to break.

Periodically check that all the spokes are tightened evenly since they stretch a certain amount during use. Standard spoke tightening torque is 0.30 kg-m (26 ft-lbs). Over- or under-tightening may cause breakage.

Rim runout

Set a dial gauge against the side of the rim, and rotate the wheel to measure axial runout. The difference between the highest and lowest dial readings is the amount of axial runout.

Set the dial gauge against the inner circumference of the rim, and rotate the wheel to measure radial runout. The difference between the highest and lowest dial readings is the amount of radial runout.

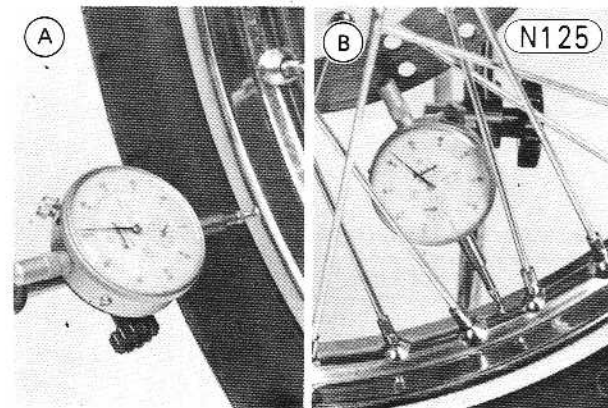

A. Axial Runout Measurement
B. Radial Runout Measurement

Table N37 Rim Runout

| | | |
|---------------|-------|--------|
| | Axial | Radial |
| Service Limit | 2 mm | 2 mm |

A certain amount of rim warp (runout) can be corrected by recentering the rim. Loosen some spokes and tighten others to change the position of different parts of the rim. If the rim is badly bent, however, it should be replaced.

Axle

A bent axle causes vibration, poor handling, and instability.

To measure axle runout, remove the axle, place it in V blocks that are 100 mm apart, and set a dial gauge to the axle at a point halfway between the blocks. Turn the axle to measure the runout. The amount of runout is the amount of dial variation.

If runout exceeds the usable range, straighten the axle within the usable range or replace it. If the axle cannot be straightened to within the usable range, or if runout exceeds the service limit, replace the axle.

Axle Runout

N126

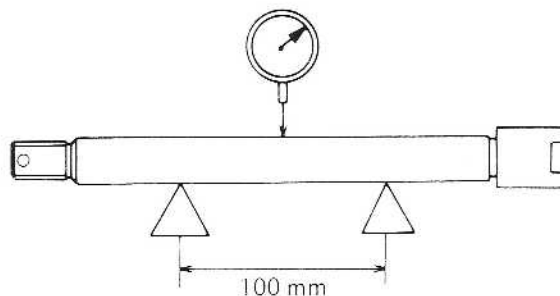

Table N38 Axle Runout/100 mm

| | | |
|----------------|--------------|---------------|
| | Usable Range | Service Limit |
| Front and Rear | 0.2 mm | 0.7 mm |

Wheel Bearings, Grease Seals

A grease seal is fitted in the speedometer gear housing, in the right side of the front hub, and in the rear wheel coupling. Each grease seal is a rubber ring equipped with a steel band on its outer circumference. The grease seal inner lip is held against the axle collar by a wire spring band. Since the grease seal not only seals in the wheel bearing grease but also keeps dirt and moisture from entering the hub, the use of a damaged grease seal will cause the wheel bearing to wear quickly.

Grease Seal

N127

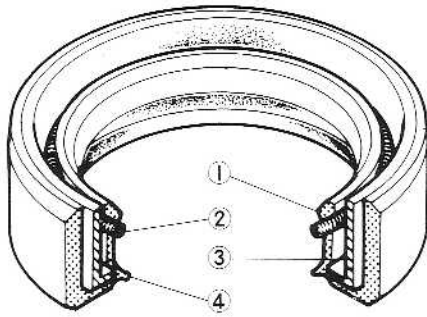

- 1. Secondary Lip
- 2. Wire Spring Band
- 3. Steel Band
- 4. Primary Lip

A wheel bearing is fitted in both sides of each hub. Since worn wheel bearings will cause play in the wheel (resulting in vibration and instability), they should be cleaned, inspected, and greased periodically.

Inspection and lubrication

If the grease seals are examined without removing the seals themselves, look for discoloration (indicating the rubber has deteriorated), hardening, damage to the internal ribbing, or other damage. If the seal or internal ribbing has hardened, the clearance between the seal and the axle sleeve will not be taken up, which will allow dirt and moisture to enter and reach the bearing. If in doubt as to its condition and whenever the seal is removed for greasing the bearing, the seal should be replaced. The seals are generally damaged upon removal.

Since the wheel bearings are made to extremely close tolerances, the clearance cannot normally be measured. Wash the bearing with a high flash-point solvent, dry it (**do not spin it while it is dry**), and oil it. Spin it by hand to check its condition. If it is noisy, does not spin smoothly, or has any rough spots, it must be replaced. If the same bearing is to be used again, re-wash it with a high flash-point solvent, dry it, and pack it with good quality bearing grease before installation. Turn the bearing by hand a few times to make sure the

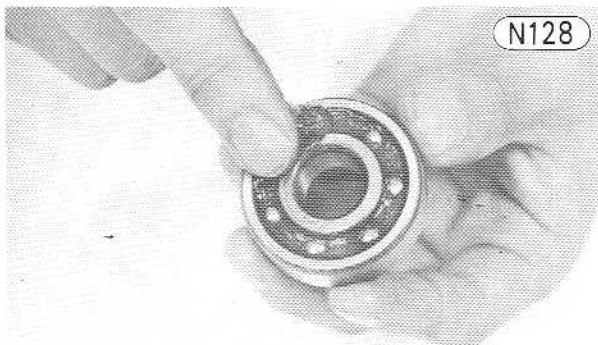

N128

grease is distributed uniformly inside the bearing, and wipe the old grease out of the hub before bearing installation. Clean and grease the wheel bearings and the front hub gear housing (speedometer gear) in accordance with the Periodic Maintenance Chart (Pg. 244).

N129

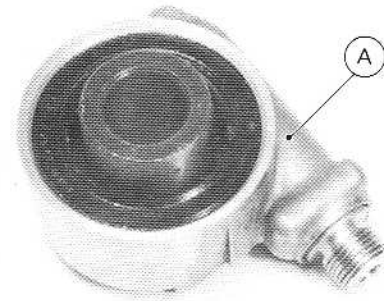

A. Speedometer Gear Housing

Rear Wheel Coupling

The rear wheel coupling connects the rear sprocket to the wheel. A rubber shock damper in the coupling absorbs some of the shock resulting from sudden changes in torque due to acceleration or braking.

Damper inspection

Remove the rear wheel coupling (Pg. 202), and inspect the rubber damper.

Replace the damper if it appears damaged or deteriorated.

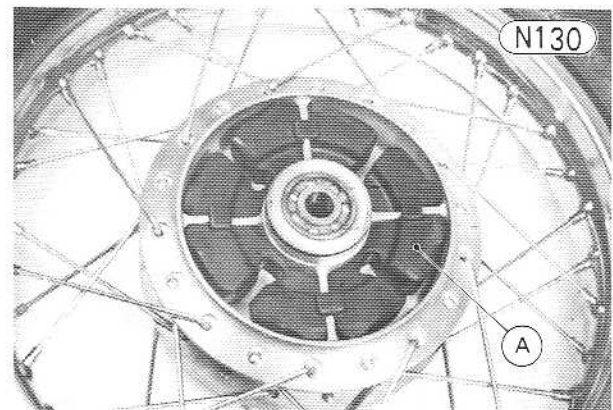

N130

A. Rubber Damper

SPROCKETS

Refer to Pg. 145, noting the following.

Table N39 Sprocket Diameter

| | Service Limit |
|--------------|---------------|
| Engine (15T) | 64.9 mm |
| Rear (33T) | 166.0 mm |

BRAKES

This motorcycle has the front disc and rear drum brake system, and the maintenance procedures are the same as those for the 1979 Z250-A1 (front brake) and 1980 Z250-B1 (rear brake). Refer to Pgs. 145 – 150 (front brake) and 209 – 211 (rear brake).

SPARK PLUGS

Refer to Pg. 163, noting the following.

Table N40 Spark Plug Specification

| Required Plug Threads | Make, Type |
|-------------------------------|------------|
| 12 mm Diameter 19 mm Reach | NGK D9EA |

Appendix

SPECIAL TOOLS

The special tools are the same as those for the 1981 Z250-A3 (Pg. 233), but the item (a) is not applied to the KZ305A.

WIRING DIAGRAM

The wiring diagram for the 1981 KZ305-A1 is shown on Pg. 255.

**KZ305-A1,A2,B1,C1,D1 Wiring Diagram
(U.S. and Canadian Models)**

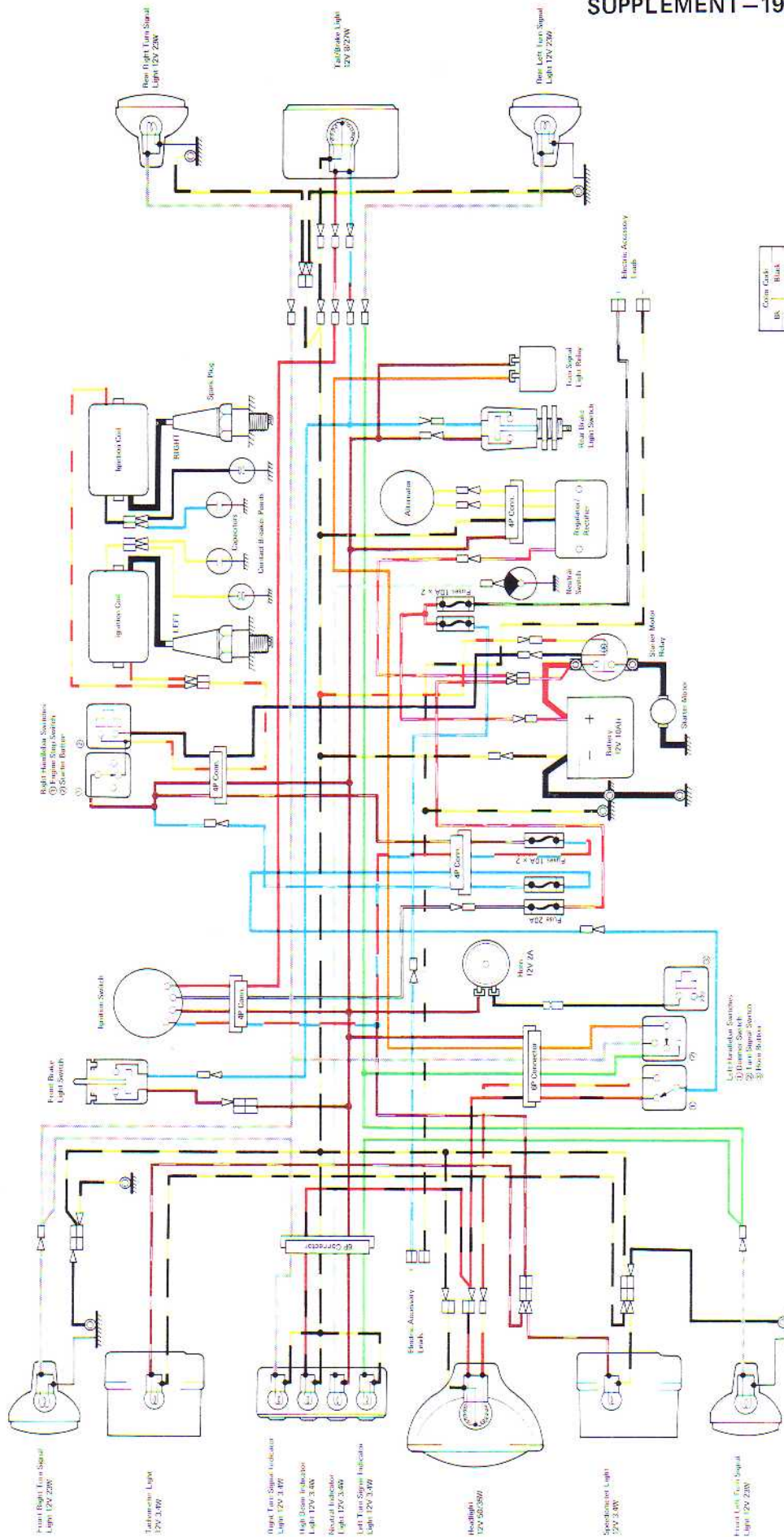

Color Code

| | |
|-------|-------------|
| Black | Black |
| Bl | Blue |
| Gr | Green |
| Y | Yellow |
| W | White |
| Br | Brown |
| Pk | Pink |
| Red | Red |
| Or | Orange |
| LC | Light Green |
| Gr | Grey |
| C | Cyan |
| G | Gold |

RIGHT HANDLEBAR SWITCH CONNECTIONS

| | | | | | |
|----------|----------------|-------------|-----------------------|-----------------------|-----------------------|
| Color | Y/R | Black | Green | Brown | Y/R |
| Function | Starter Switch | Kill Switch | Emergency Stop Switch | Emergency Stop Switch | Emergency Stop Switch |

IGNITION SWITCH CONNECTIONS

| | | | | | |
|----------|----------|----------|----------|----------|----------|
| Color | Gr | Bl | Wh | Br | Red |
| Function | Ignition | Ignition | Ignition | Ignition | Ignition |

LEFT HANDLEBAR SWITCH CONNECTIONS

| | | | | | | | |
|----------|-----------------------|-----------------------|-----------------------|-----------------------|-----------------------|-----------------------|-----------------------|
| Color | Bl | Wh | Gr | Gr | Bl | Bl | Bl |
| Function | Emergency Stop Switch | Emergency Stop Switch | Emergency Stop Switch | Emergency Stop Switch | Emergency Stop Switch | Emergency Stop Switch | Emergency Stop Switch |

178694

Supplement for 1981 KZ305-C1

NOTE: The maintenance and repair procedures for the KZ305C are newly included in this section. Unless otherwise noted, procedures for the 1981 KZ305-C1 are the same as those for their standard model 1979 Z250-A1.

Table of Contents

| | |
|---|-----|
| MODEL IDENTIFICATION | 257 |
| SPECIFICATIONS | |
| SPECIFICATIONS | 259 |
| PERIODIC MAINTENANCE CHART | 259 |
| ADJUSTMENT | |
| IGNITION TIMING | 259 |
| CAMSHAFT CHAIN | 259 |
| THROTTLE CABLE | 259 |
| REAR SHOCK ABSORBER | 259 |
| LUBRICATION | 259 |
| FUEL SYSTEM | 259 |
| HEADLIGHT | 259 |
| BRAKES | 259 |
| DISASSEMBLY | |
| TORQUE AND LOCKING AGENT | 259 |
| CARBURETORS | 259 |
| CAMSHAFT CHAIN TENSIONER | 259 |
| PISTON, PISTON RINGS | 259 |
| ENGINE SPROCKET | 259 |
| TRANSMISSION | 259 |
| FRONT WHEEL | 259 |
| FRONT BRAKE | 259 |
| CYLINDER HEAD COVER, ROCKER ARM | 259 |
| CLUTCH | 259 |
| REAR WHEEL, BRAKE, COUPLING | 259 |
| MAINTENANCE | |
| ROCKER ARMS, SHAFTS | 263 |
| CAMSHAFT | 263 |
| CAMSHAFT CHAIN, GUIDES, TENSIONER | 263 |
| CYLINDER HEAD, VALVES | 263 |
| SWING ARM | 263 |
| IGNITION SYSTEM | 263 |
| CYLINDER BLOCK, PISTONS | 263 |
| TRANSMISSION | 263 |
| SPROCKETS | 263 |
| CARBURETORS | 264 |
| WHEELS | 264 |
| BRAKES | 264 |
| APPENDIX | |
| SPECIAL TOOLS | 264 |
| WIRING DIAGRAM | 264 |

Model Identification

KZ305-C1 Right Side View



KZ305-C1 Left Side View



PERIODIC MAINTENANCE CHART (KZ305-C1)

The maintenance and adjustments must be done in accordance with this chart to keep the motorcycle in good running condition. The initial maintenance is vitally important and must not be neglected.

| OPERATION | FREQUENCY | ODOMETER READING * | | | | | | | |
|---|--------------|--------------------|----------|-----------|-----------|-----------|-----------|-----------|----------|
| | | 800 km | 5,000 km | 10,000 km | 15,000 km | 20,000 km | 25,000 km | 30,000 km | See Page |
| Battery electrolyte level — check † | month | • | • | • | • | • | • | • | 156 |
| Brake — check † | | • | • | • | • | • | • | • | 259 |
| Brake light switch — check † | | • | • | • | • | • | • | • | 26 |
| Brake wear — check † | | | • | • | • | • | • | • | 264 |
| Brake fluid level — check † | month | • | • | • | • | • | • | • | 264 |
| Brake fluid — change | year | | | • | | • | | • | 264 |
| Clutch — adjust | | • | • | • | • | • | • | • | 20 |
| Carburetor operation — check † | | • | • | • | • | • | • | • | 18 |
| Throttle grip — check † | | • | • | • | • | • | • | • | 259 |
| Steering play — check † | | • | • | • | • | • | • | • | 26 |
| Drive chain wear — check † | | | • | • | • | • | • | • | 144 |
| Front fork — clean | | | • | • | • | • | • | • | 151 |
| Nuts, Bolts, Fasteners — check † | | • | | • | | • | | • | 259 |
| Spark plug — clean and gap † | | • | • | • | • | • | • | • | 12 |
| Ignition timing — check † | | • | • | • | • | • | • | • | 259 |
| Valve clearance — check † | | • | • | • | • | • | • | • | 16 |
| Air cleaner element — clean | | | • | | • | | • | | 115 |
| Air cleaner element — replace | 5 cleanings | | | • | | • | | • | 115 |
| Fuel system — clean | | | | • | | • | | • | 259 |
| Tire tread wear — check † | | | • | • | • | • | • | • | 264 |
| Engine oil — change | year | • | • | • | • | • | • | • | 22 |
| Oil filter — replace | | • | | • | | • | | • | 22 |
| General lubrication — perform | | | • | • | • | • | • | • | 259 |
| Front fork oil — change | | | | • | | • | | • | 152 |
| Timing advancer — lubricate | | | | • | | • | | • | 162 |
| Swing arm — lubricate | | | | • | | • | | • | 259 |
| Wheel bearing — lubricate | 2 years | | | | | • | | | 143 |
| Speedometer gear — lubricate | 2 years | | | | | • | | | 143 |
| Brake camshaft — lubricate | 2 years | | | | | • | | | 264 |
| Steering stem bearing — lubricate | 2 years | | | | | • | | | 150 |
| Master cylinder cup and dust seal — replace | 2 years | | | | | | | | 264 |
| Caliper piston seal and dust seal — replace | 2 years | | | | | | | | 264 |
| Brake hose — replace | 4 years | | | | | | | | 264 |
| Fuel hose — replace | 4 years | | | | | | | | — |
| Drive chain — lubricate | Every 300 km | | | | | | | | 144 |
| Drive chain slack — check † | Every 800 km | | | | | | | | 24 |

* For higher odometer readings, repeat at the frequency interval established here.

† Replace, add, adjust or torque if necessary.

Specifications

SPECIFICATIONS

The specifications for the 1981 KZ305-C1 are shown on Pg. 242.

PERIODIC MAINTENANCE CHART

The Periodic Maintenance Chart for the 1981 KZ305-C1 is shown on Pg. 258.

Adjustment

The adjustment procedures for the following five items are the same as those for the 1981 Z250-A3. Refer to the supplement for the 1981 Z250-A3.

- IGNITION TIMING (See Pg. 217)
- CAMSHAFT CHAIN (See Pg. 217)
- THROTTLE CABLE (See Pg. 217)
- REAR SHOCK ABSORBER (See Pg. 217)
- LUBRICATION (See Pg. 218)

The adjustment procedures for the following two items are the same as those for the 1981 KZ305-A1. Refer to the supplement for the KZ305-A1.

- FUEL SYSTEM (See Pg. 245)
- HEADLIGHT (See Pg. 246)

BRAKES

This motorcycle has the front disc and rear drum brake system. Adjust the front and rear brakes referring to Pg. 25 (front brake) and Pg. 193 (rear brake).

Disassembly

The procedures for the following eight items are the same as those for the 1981 Z250-A3. Refer to the supplement for the Z250-A3.

- TORQUE AND LOCKING AGENT (See Pg. 218)
- CARBURETORS (See Pg. 218)
- CAMSHAFT CHAIN TENSIONER (See Pg. 223)
- PISTON, PISTON RINGS (See Pg. 224)
- ENGINE SPROCKET (See Pg. 225)
- TRANSMISSION (See Pg. 225)
- FRONT WHEEL (See Pg. 225)
- FRONT BRAKE (See Pg. 227)

The procedures for the following two items are the same as those for the 1980 Z250-A2. Refer to the supplement for the 1980 Z250-A2.

- CYLINDER HEAD COVER, ROCKER ARM (See Pg. 184)
- CLUTCH (See Pg. 184)

REAR WHEEL, BRAKE, COUPLING

Removal:

- Raise the rear wheel off the ground.
- Remove the drive chain from the rear sprocket as explained in drive chain removal (Pg. 97). The engine sprocket cover does not require removal.
- Remove the clip, nut, lockwasher, and bolt at the rear end of the torque link.

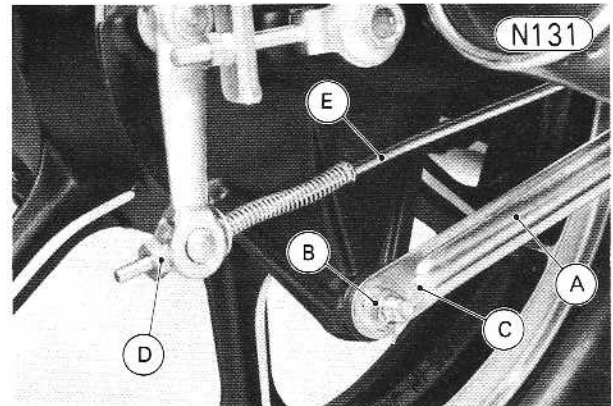

A. Torque Link
B. Nut
C. Clip

D. Adjusting Nut
E. Rod

- Pull off the cotter pin, loosen the axle nut, and unscrew the adjusting nut from the brake rod.

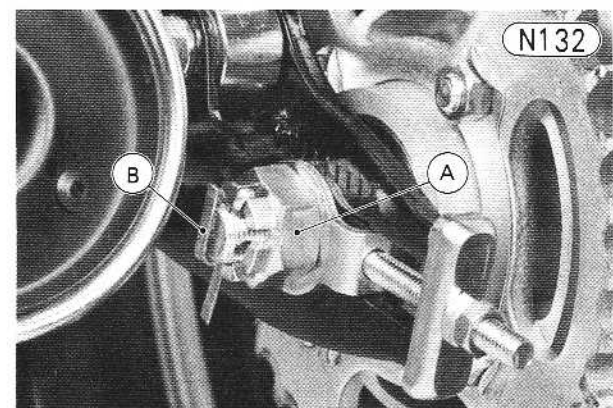

A. Axle Nut

B. Cotter Pin

- Pull the rear wheel toward the rear together with the wheel coupling and brake panel with the axle inserted through them.
- Remove the rod joint and spring off the cam lever and rod.

Installation:

- Apply a little grease to the inside surface of the hole in the coupling where the rear hub fits.
- Check to see that the coupling rubber damper ⑬ is fitted in the rear hub.
- Insert the axle from the right side through the right chain adjuster, spacer ⑲, brake panel ⑳, coupling sleeve ⑮, coupling collar ⑩, and left chain adjuster.
- Install the axle nut on the axle a few turns.
- Slip the rear wheel into the end of the swing arm.
- Fit the drive chain onto the rear sprocket and install the drive chain master link and clip. The direction of the master link clip should be as shown in Fig G 25.
- Fit the brake rod joint to the cam lever.
- Install the spring on the end of the brake rod, fit the rod through the joint, and screw on the adjusting nut.
- Insert the torque link bolt into the brake panel, and install the torque link, lockwasher, and nut finger tight.
- Adjust the drive chain (Pg. 24).
- Adjust the rear brake (Pg. 193).
- Check the rear brake light switch and adjust if necessary (Pg. 26).

Rear Brake Disassembly:

WARNING Brake linings contain asbestos fiber. Inhalation of asbestos may cause serious scarring of the lungs and may promote other internal injury and illness, including cancer. Observe the following precautions when handling brake linings:

1. Never blow brake linings dust with compressed air.
2. If any components are to be cleaned, wash with detergent, then immediately discard the cleaning solution and wash your hands.
3. Do not grind any brake lining material unless a ventilation hood is available and properly used.

- Remove the brake panel ⑳ from the wheel.
- Using a clean cloth around the linings to prevent grease or oil from getting on them, remove the brake shoes ㉔ ㉕, by pulling up on the center of the linings.

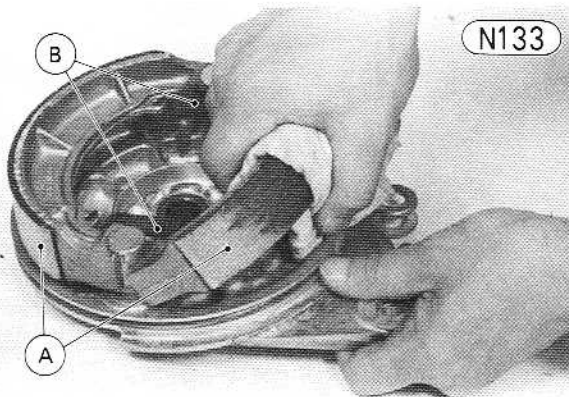

A. Brake Shoes B. Springs

- Remove the springs ㉕, ㉖ (2) to separate the two brake shoes.
- Mark the position of the cam lever ㉗ so that it can be installed later in the same position.
- Unbolt and remove the cam lever, brake lining wear indicator ㉘, dust seal ㉙, and camshaft ㉚.

Rear Brake Assembly:

- Lubricate the brake parts (Pg. 210).
- Put the camshaft back into the panel.
- Fit the springs onto the brake shoes, and wrapping a clean cloth around the linings to prevent grease or oil from getting on them, install the shoes on the brake panel.
- Fit the dust seal and the indicator on the serration so that it points to the extreme right of the **USABLE RANGE**.

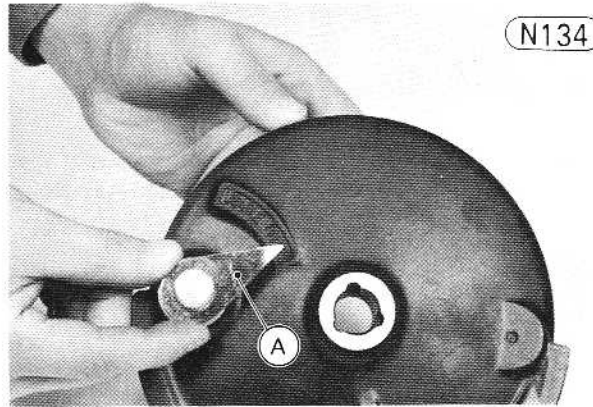

A. Indicator

- Install the cam lever in its original position on the camshaft, and tighten its bolt.

Wheel Coupling Disassembly:

- Straighten the bent portions of the double washers ⑭ (2).
- Remove the rear sprocket nuts ③ (4) and double washers to separate the rear sprocket ⑤ and wheel coupling ⑭.

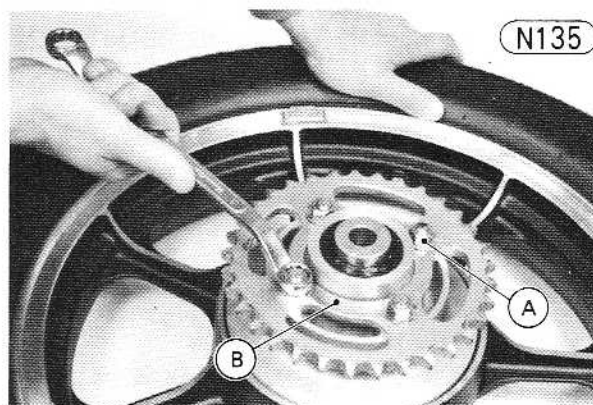

A. Sprocket Nut B. Double Washer

Rear Hub

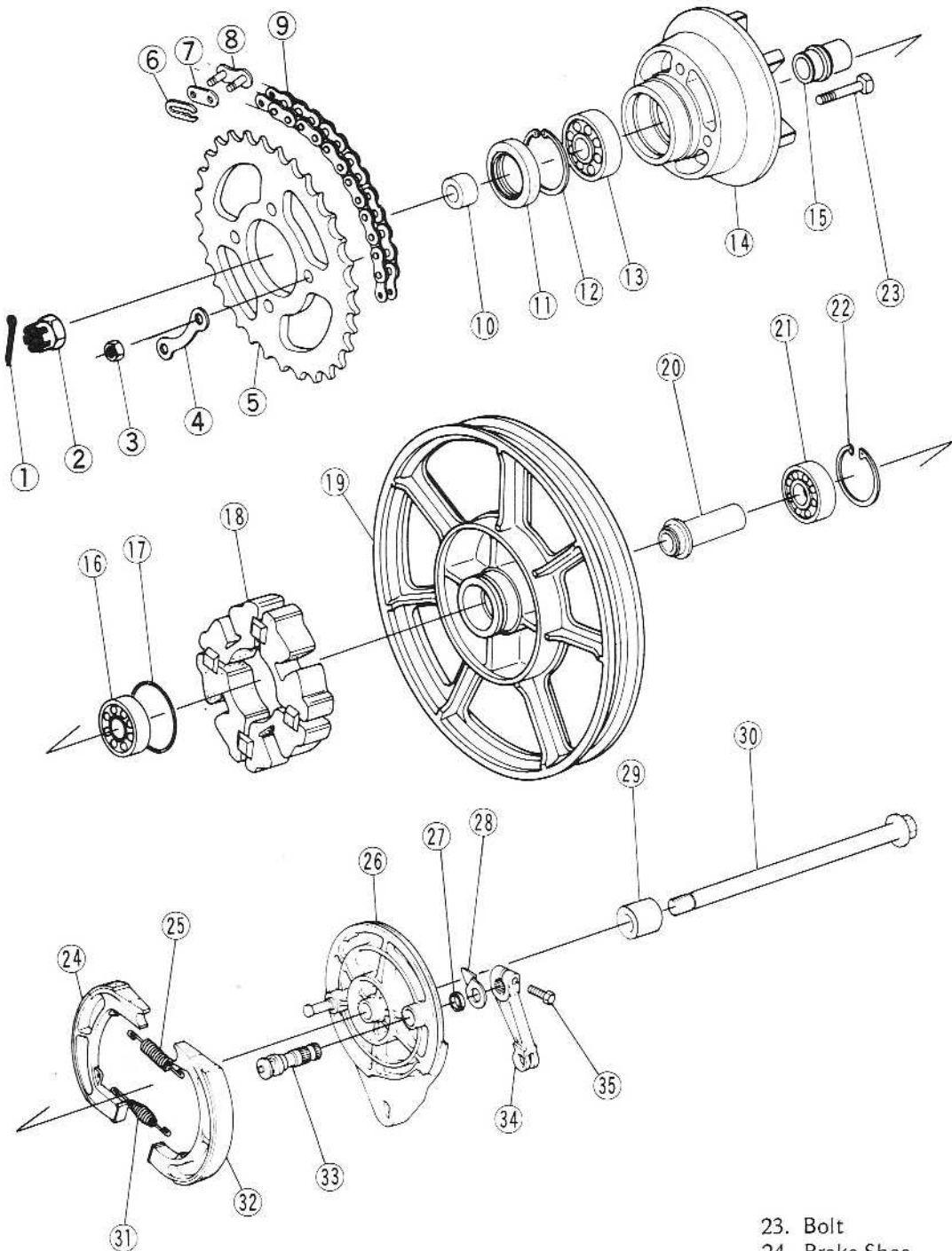

- 1. Cotter Pin
- 2. Axle Nut
- 3. Nut
- 4. Double Washer
- 5. Rear Sprocket
- 6. Clip
- 7. Side Plate
- 8. Master Link
- 9. Drive Chain
- 10. Coupling Collar
- 11. Grease Seal

- 12. Circlip
- 13. Ball Bearing
- 14. Coupling
- 15. Coupling Sleeve
- 16. Ball Bearing
- 17. O-ring
- 18. Rubber Damper
- 19. Wheel
- 20. Distance Collar
- 21. Ball Bearing
- 22. Circlip

- 23. Bolt
- 24. Brake Shoe
- 25. Spring
- 26. Brake Panel
- 27. Dust Seal
- 28. Wear Indicator
- 29. Spacer
- 30. Rear Axle
- 31. Spring
- 32. Brake Shoe
- 33. Brake Cam
- 34. Brake Cam Lever
- 35. Bolt

- Remove the coupling and rubber damper ⑱ from the wheel.
- Pull out the coupling collar ⑩ from the left, and the coupling sleeve ⑮ from the right.
- Using a hook, pull off the grease seal ⑪ .

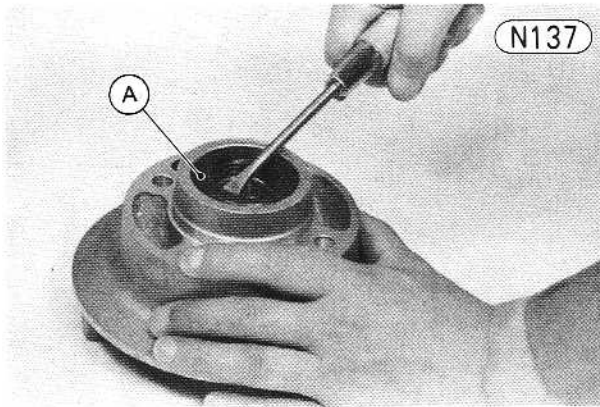

A. Grease Seal

- Remove the circlip ⑫ .
- Remove the bearing ⑬ by tapping from the wheel side evenly around the bearing inner race.

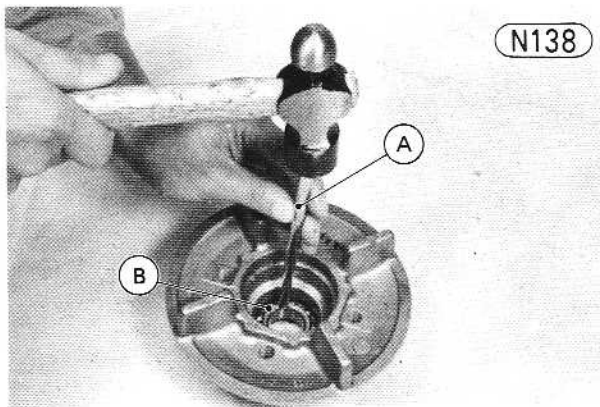

A. Rod

B. Bearing Inner Race

Wheel Coupling Assembly:

- Inspect the bearing, and replace if necessary (Pg. 143).
- Lubricate it (Pg. 143), and install it using the inner-driver, outer driver, and the bearing driver holder (special tools). Drive the bearing in until it stops at the bottom of the hole.

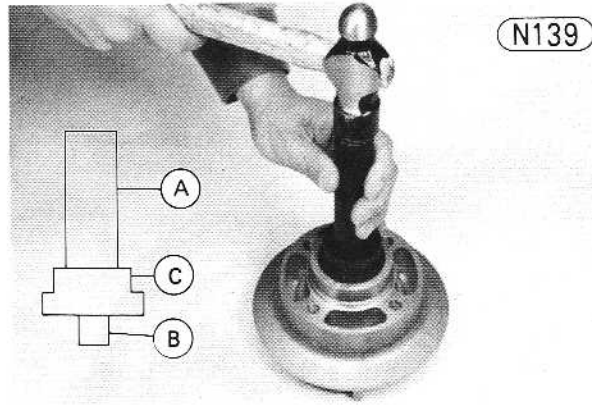

- A. Bearing Driver Holder (57001-1132)
- B. Inner Driver (57001-1139; $\phi 35$)
- C. Outer Driver (57001-1146; $\phi 46 \times \phi 51$)

- Install the circlip.
- Replace the grease seal with a new one using a suitable driver. Drive in the seal until the face of the seal is level with the end of the grease seal hole.
- Install the rear sprocket, double washers (2) and nuts (4), and install the nuts finger tight.

WARNING The rear sprocket must be installed with the chamfered hole side facing toward the coupling. If not, the sprocket will not seat on the coupling evenly, causing the drive chain to be thrown off by excessive sprocket runout during operation. This can result in rear wheel lockup and loss of control.

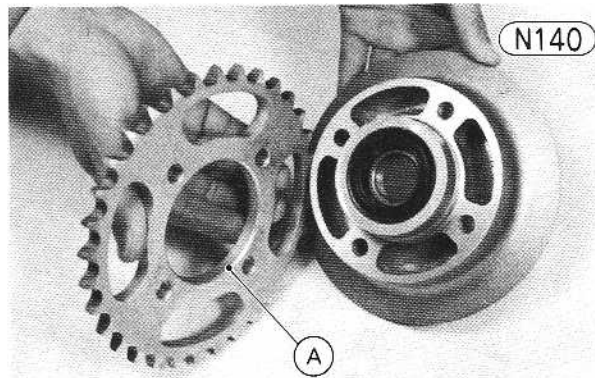

A. Chamfer

- Inspect the O ring ⑰ on the rear hub, replace it with a new one if it has deteriorated and apply a little grease to the O ring.
- Install the coupling sleeve on the right side and the coupling collar on the left side of the coupling.
- Install the rubber damper and wheel coupling on the rear hub, and then tighten the sprocket nuts to 3.0 kg-m (22 ft-lbs) of torque.

Rear Hub Disassembly:

- Remove the wheel coupling ⑭ , rear brake panel ⑳ , and rubber damper ⑲ from the wheel.
- Remove the circlip ㉒ .
- Insert a metal rod into the hub from the wheel coupling side, and remove the right side bearing ㉑ by tapping evenly around the bearing inner race. The distance collar ㉔ will come out with the bearing.
- Insert the metal rod into the hub from the other side, and tap out the remaining bearing ⑮ .

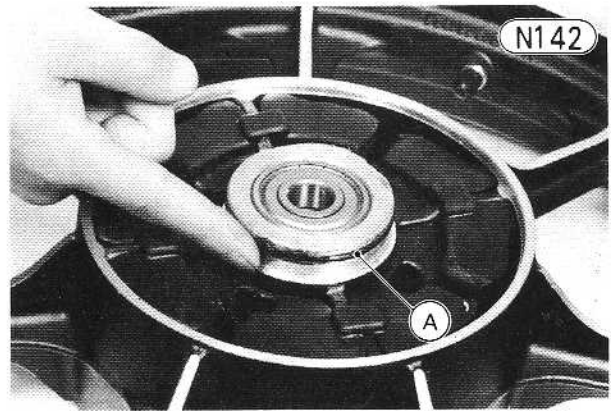

A. O Ring

Rear Hub Assembly:

- Inspect the bearings and replace them if necessary (Pg. 143).
- Lubricate the ball bearings (Pg. 143).
- Before installing the wheel bearings, blow any dirt or foreign particles out of the hub with compressed air to prevent contamination of the bearings.
- Install the coupling side ball bearing facing the shield outward using the inner driver, outer driver and bearing driver holder (special tools). Press the bearing in until it stops at the bottom of the hole.

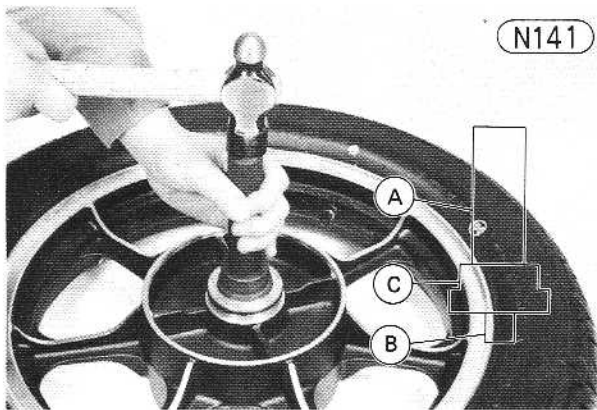

- A. Bearing Driver Holder (57001-1132)
- B. Inner Driver (57001-1136; ϕ 17)
- C. Outer Driver (57001-1145; ϕ 42 x ϕ 47)

- Put the distance collar into the hub.
- Install the brake panel side bearing facing the shield outward. Press the bearing in until it stops at the bottom of the hole using the inner and outer drivers and bearing driver holder (special tools: P/N 57001-1136, 1145, 1132).
- Install the circlip.
- Inspect the O ring ⑰ on the rear hub and replace it if necessary. Apply a little grease to the O ring before fitting the coupling on the rear hub.

Maintenance

The following two items are the same as those for the 1980 Z250-A2. Refer to the supplement for the 1980 Z250-A2.

- ROCKER ARMS, SHAFTS (See Pg. 185)
- CAMSHAFT (See Pg. 185)

The following four items are the same as those for the 1981 Z250-A3. Refer to the supplement for the 1981 Z250-A3.

- CAMSHAFT CHAIN, GUIDES, TENSIONER (See Pg. 230)
- CYLINDER HEAD, VALVES (See Pg. 230)
- SWING ARM (See Pg. 232)
- IGNITION SYSTEM (See Pg. 232)

The following three items are the same as those for the 1981 KZ305-A1. Refer to the supplement for the KZ305-A1.

- CYLINDER BLOCK, PISTONS (See Pg. 251)
- TRANSMISSION (See Pg. 251)
- SPROCKETS (See Pg. 253)

CARBURETORS

Refer to Pgs. 115~119, noting the following.

Table N41 Carburetor Specifications

| | |
|-------------------------|--------------|
| Type | CV32 |
| Primary Main Jet | #65 |
| Secondary Main Jet | #82 |
| Pilot Air Jet | #120 |
| Primary Main Air Jet | #150 |
| Secondary Main Air Jet: | |
| Left | #70 |
| Right | #50 |
| Pilot Jet | #35 |
| Pilot Screw | 2¼ turns out |
| Service Fuel Level | 1.5~3.5 mm |

Appendix

SPECIAL TOOLS

The special tools are the same as those for the 1981 Z250-A3 (Pg. 233), but the item (a) is not applied to the KZ305C.

WIRING DIAGRAM

The wiring diagram for the 1981 KZ305-C1 is shown on Pg. 255.

WHEELS

Refer to Pgs. 140~143, noting the following.

Table N42 Tires, Air Pressure (measured when cold)

| | Air Pressure | | Size | Make, Type |
|-------|---|--|----------------------|---------------------|
| Front | 1.75 kg/cm ² (175kPa, 25 psi) | | 3.00S-18 4PR | Dunlop F8 |
| Rear | Up to 97.5 kg | 1.5 kg/cm ² (150 kPa, 21 psi) | 120/90-16 63S | Dunlop K 327 |
| | 97.5~ 155 kg | 2.0 kg/cm ² (200 kPa, 28 psi) | | |

Table N43 Tire Tread Depth

| Service Limit | | |
|---------------|------------------|------|
| Front | 1 mm | |
| Rear | under 110 kph | 2 mm |
| | over 110 kph | 3 mm |

Table N44 Rim Size

| | |
|-------|-----------|
| Front | 1.60 x 18 |
| Rear | 2.50 x 16 |

BRAKES

This motorcycle has the front disc and rear drum brake system, and maintenance procedures are the same as those for the 1979 Z250-A1 (front brake) and 1980 Z250-B1 (rear brake). Refer to Pgs.145 ~ 150 (front brake) and 209 ~ 211 (rear brake).

Supplement for 1982 Z250-A4

Table of Contents

| | |
|----------------------------------|-----|
| MODEL IDENTIFICATION | 266 |
| SPECIFICATIONS | |
| SPECIFICATIONS | 267 |
| PERIODIC MAINTENANCE CHART | 269 |
| ADJUSTMENT | |
| CLUTCH | 270 |
| FUEL SYSTEM | 270 |
| HEADLIGHT | 271 |
| FRONT FORK | 271 |
| DISASSEMBLY | |
| TORQUE AND LOCKING AGENT | 272 |
| ENGINE SPROCKET COVER | 272 |
| CLUTCH RELEASE | 272 |
| RIGHT ENGINE COVER | 274 |
| CLUTCH | 274 |
| FRONT FORK | 276 |
| MAINTENANCE | |
| FRONT FORK | 276 |
| APPENDIX | |
| SPECIAL TOOLS | 276 |
| WIRING DIAGRAMS | 276 |

Model Identification

Z250-A4 Left Side View

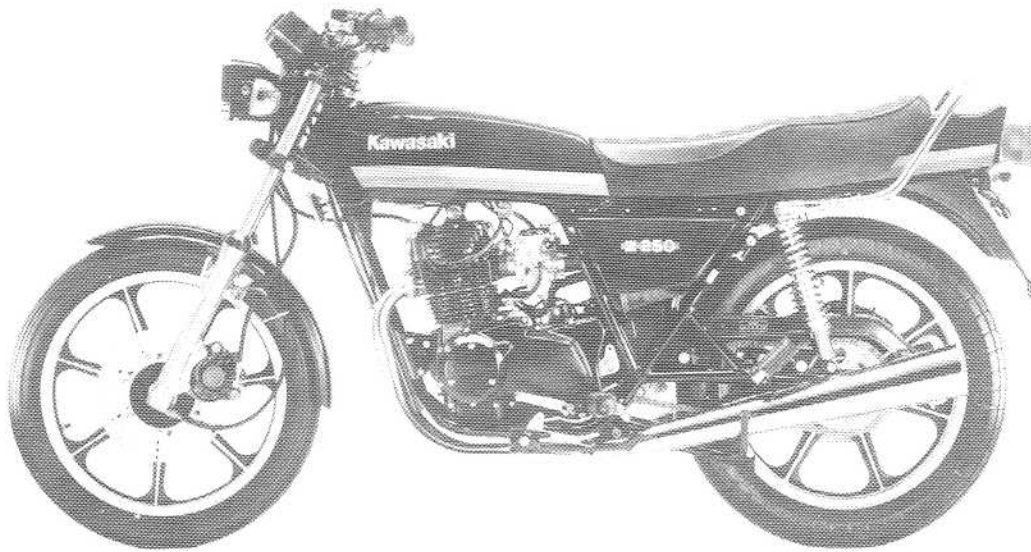

Z250-A4 Right Side View

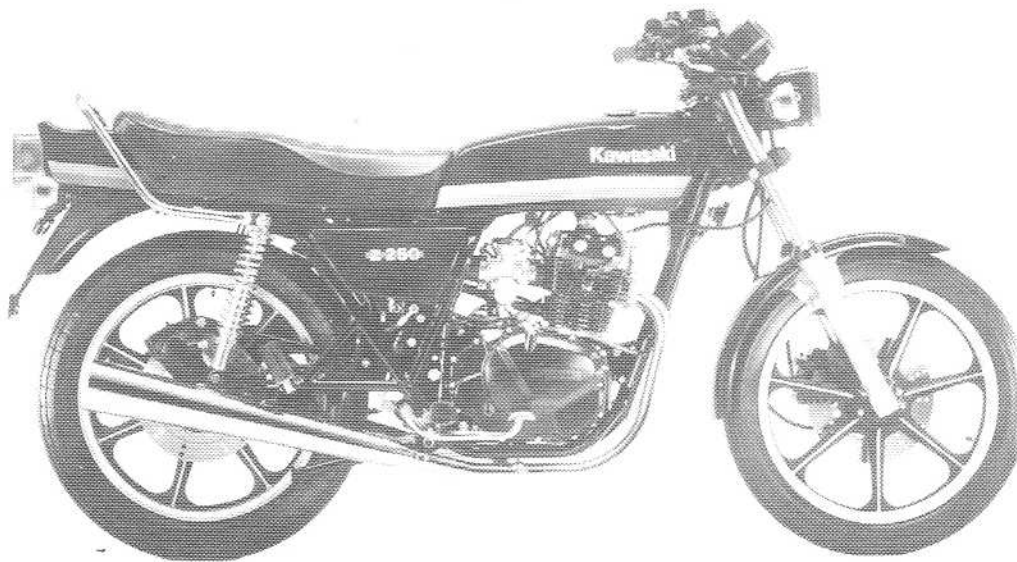

Specifications

SPECIFICATIONS

| | Z250-A4 | Z250-B3 | |
|--|---|---|---|
| Dimensions | | | |
| Overall length | 2,020mm, (E) (A) 2,060mm (UK) 2,060mm | (UK) 2,015mm (A) 2,060mm | |
| Overall width | 740mm | 705mm | |
| Overall height | 1,070mm | 1,050mm | |
| Wheelbase | 1,340mm | * | |
| Road clearance | 140mm | 155mm | |
| Seat height | 805mm | * | |
| Dry weight | 153 kg | 147 kg | |
| Fuel tank capacity | 13.6 L | * | |
| Performance | | | |
| Climbing ability | 25° | * | |
| Braking distance | 12.5 m from 50 km/h | 14m from 50 km/h | |
| Minimum turning radius | 2.2 m | * | |
| Engine | | | |
| Type | SOHC 2-cylinder, 4 stroke | * | |
| Cooling system | Air cooled | * | |
| Bore and stroke | 55.0 x 52.4 mm | * | |
| Displacement | 0.248 L | * | |
| Compression ratio | 9.5 | * | |
| Maximum horsepower | 27 HP @10,000 r/min (rpm), (C) 26.7 HP @1,000 r/min (rpm) | * | |
| Maximum torque | 21 N-m (2.1 kg-m) @8,000 r/min (rpm) (C) 20 N-m (2.02 kg-m) @8,000 r/min (rpm) | * | |
| Valve timing: | | | |
| Inlet | Open | 21° BTDC | * |
| | Close | 59° ABDC | * |
| | Duration | 260° | * |
| Exhaust | Open | 61° BBDC | * |
| | Close | 19° ATDC | * |
| | Duration | 260° | * |
| Carburetors | Keihin CV32 x 2 | * | |
| Lubrication system | Forced lubrication (wet sump) | * | |
| Engine oil: | Grade | SE class | * |
| | Viscosity | SAE 10W40, 10W50, 20W40, or 20W50 | * |
| | Capacity | 1.8L, 1.5L (without filter change) | * |
| Starting system | Electric starter | * | |
| Ignition system | Battery and coil | * | |
| Ignition timing (Mechanically advanced) | | From 10° BTDC | * |
| | | @1,250 r/min (rpm) to 40° BTDC @2,500 r/min (rpm) | * |
| Spark plugs | NGK D8EA or ND X24ES-U, (E) NGK DR8ES or ND X24ESR-U | * | |

Drive Train

Primary reduction system:

| | | |
|---------------------|---|---|
| Type | Gear | * |
| Reduction ratio | 3.736 (71/19) | * |
| Clutch type | Wet, multi disc | * |
| Transmission | | |
| Type | 6-speed, constant mesh, return shift | * |
| Gear ratio: 1st | 2.600 (39/15) | * |
| 2nd | 1.789 (34/19) | * |
| 3rd | 1.400 (31/22) | * |
| 4th | 1.160 (29/25) | * |
| 5th | 1,000 (27/27) | * |
| 6th | 0,892 (25/28) | * |
| Final drive system: | | |
| Type | Chain drive | * |
| Reduction ratio | 2.333 (35/15) | * |
| Overall drive ratio | 7.785 (@Top gear) | * |

Electric Equipment

| | | | |
|-------------------|--------------|--------------------------------------|--------------|
| Alternator: | Type | Single-phase AC | * |
| | Rated output | 13.5 amp. @8,000 r/min (rpm), 14V | * |
| Voltage regulator | | Open-circuit type | * |
| Battery | | 12V 10AH | * |
| Headlight: | Type | Semi-sealed | * |
| | Bulb | 12V 60/55W | Ⓢ 12V 35/35W |
| | | | Ⓢ 12V 50/40W |
| Tail/Brake light | | 12V 8/27W, Ⓢ Ⓢ 12V 5/21W | * |

Frame

| | | | |
|---------------------|------------------------|-----------------------------|-----------------|
| Type | Tubular, single cradle | * | |
| Steering angle | 40° to either side | * | |
| Castor (rake angle) | 27° | * | |
| Trail | 100 mm | * | |
| Tire size: | Front | 3.00S-18 4PR | * |
| | Rear | 3.50S-18 4PR | * |
| Suspension: | Front | Telescopic fork (Pneumatic) | Telescopic fork |
| | Rear | Swing arm | * |
| Wheel travel: | Front | 150 mm | * |
| | Rear | 98 mm | * |

Brakes

| | | | |
|-------|-------|-------------------|--------------------------------------|
| Type: | Front | Single disc brake | Internal expansion, two leading |
| | Rear | Single disc brake | Internal expansion, leading-trailing |

*: Identical to Z250-A4

Ⓢ: Australian model, Ⓢ: European model, Ⓢ: European model except Italian model

Ⓢ: West German model, Ⓢ: U.K. model

Specifications subject to change without notice, and may not apply to every country.

PERIODIC MAINTENANCE CHART (Z250-A4)

The maintenance and adjustments must be done in accordance with this chart to keep the motorcycle in good running condition. The initial maintenance is vitally important and must not be neglected.

| OPERATION | FREQUENCY | Whichever comes first ↓ | ODOMETER READING* | | | | | | | See Page |
|---|-------------|----------------------------|-------------------|----------|-----------|-----------|-----------|-----------|-----------|----------|
| | | | 800 km | 5,000 km | 10,000 km | 15,000 km | 20,000 km | 25,000 km | 30,000 km | |
| Engine oil – change | Every year | • | • | • | • | • | • | • | • | 22 |
| Oil filter – replace | | • | | • | | • | | • | | 22 |
| Fuel system – clean | | | | • | | • | | • | | 270 |
| Fuel hose – replace | 4 years | | | | | | | | | – |
| Spark plug – clean and gap † | | • | • | • | • | • | • | • | • | 12 |
| Ignition timing – check † | | • | • | • | • | • | • | • | • | 217 |
| Timing advancer – lubricate | | | | • | | • | | • | | 162 |
| Valve clearance – check † | | • | • | • | • | • | • | • | • | 16 |
| Air cleaner element – clean | | | • | | • | | • | | | 115 |
| Air cleaner element – replace | 5 cleanings | | | • | | • | | • | | 115 |
| Throttle grip play – check † | | • | • | • | • | • | • | • | • | 217 |
| Idle speed – check † | | • | • | • | • | • | • | • | • | 18 |
| Carburetor synchronization – check † | | • | • | • | • | • | • | • | • | 19 |
| Clutch – adjust | | • | • | • | • | • | • | • | • | 270 |
| Drive chain wear – check † | | | • | • | • | • | • | • | • | 144 |
| Drive chain – lubricate | 300 km | | | | | | | | | 144 |
| Drive chain slack – check † | 800 km | | | | | | | | | 24 |
| Brake lining wear – check † | | | • | • | • | • | • | • | • | 145 |
| Brake fluid level – check † | month | • | • | • | • | • | • | • | • | 145 |
| Brake fluid – change | year | | | • | | • | | • | | 145 |
| Brake hose – replace | 4 years | | | | | | | | | 150 |
| Caliper piston seal and dust seal—replace | 2 years | | | | | | | | | 148 |
| Master cylinder cup and dust seal—replace | 2 years | | | | | | | | | 147 |
| Brake play – check † | | • | • | • | • | • | • | • | • | 25 |
| Brake light switch – check † | | • | • | • | • | • | • | • | • | 26 |
| Steering play – check † | | • | • | • | • | • | • | • | • | 26 |
| Steering stem bearing – lubricate | 2 years | | | | | • | | | | 150 |
| Front fork oil – change | | | | • | | • | | • | | 276 |
| Front fork oil seal – clean | | | • | • | • | • | • | • | • | 151 |
| Tire wear – check † | | | • | • | • | • | • | • | • | 140 |
| Wheel bearing – lubricate | 2 years | | | | | • | | | | 143 |
| Speedometer gear – lubricate | 2 years | | | | | • | | | | 89 |
| Swing arm pivot – lubricate | | | | • | | • | | • | | 218 |
| Battery electrolyte level – check † | month | • | • | • | • | • | • | • | • | 156 |
| General lubrication – perform | | | • | • | • | • | • | • | • | 29 |
| Nut, bolt, and fastener tightness –check† | | • | • | • | • | • | • | • | • | 272 |

* For higher odometer readings, repeat at the frequency interval established here.

† Replace, add, adjust or torque if necessary.

Adjustment

CLUTCH

WARNING To avoid a serious burn, never touch the engine or exhaust pipes during clutch adjustment.

Adjustment

- Loosen the locknut and mounting nuts.
- Turn one cable adjuster and slide the other until the correct clutch lever play is obtained. Tighten the locknut and mounting nuts.

Table N45 Clutch Lever Play

Clutch Lever Play: 2 – 3 mm

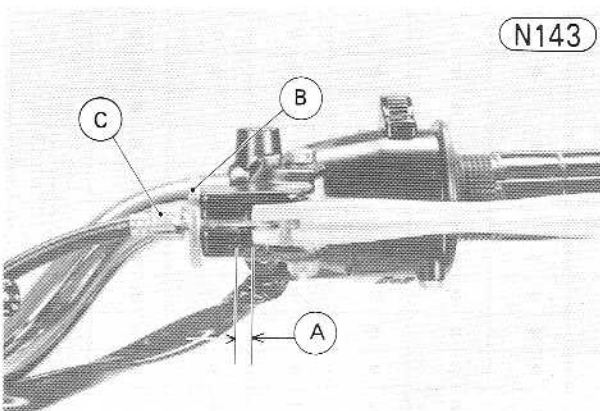

A. Clutch Lever Play
B. Locknut
C. Adjuster

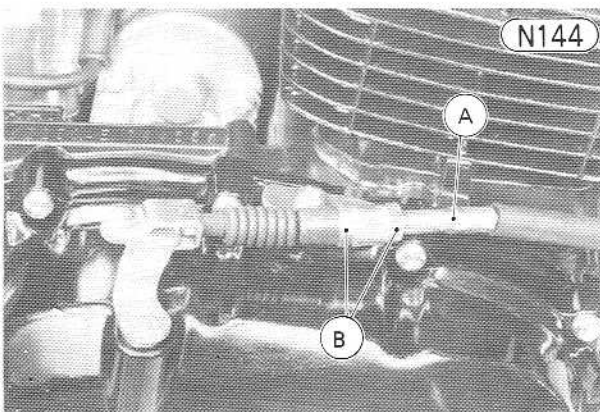

A. Adjuster
B. Mounting Nuts

WARNING Be sure the upper end of the clutch outer cable is fully seated in its fitting, or it could slip into place later, creating enough cable play to prevent clutch disengagement, resulting in a hazardous riding condition.

- After the adjustment is made, start the engine and check that the clutch does not slip and that it releases properly.

FUEL SYSTEM

Accumulation of moisture or sediment in the fuel system will restrict the flow of fuel and cause carburetor and/or fuel tap malfunction.

- WARNING**
1. Gasoline is extremely flammable and can be explosive under certain conditions. Turn the ignition switch OFF. Do not smoke. Make sure the area is well ventilated and free from any source of flame or sparks; this includes any appliance with a pilot light.
 2. Make sure the engine is cold before working. Wipe any fuel off the engine before starting it.

Inspection

- Turn the fuel tap lever to the position where the fuel does not flow.
- Run the lower ends of the carburetor overflow tubes into a suitable container.
- Turn out each drain plug a few turns to drain the carburetors, and check to see if water or dirt comes out.
- ★ If any water or dirt comes out, clean the fuel system as follows.
- Tighten the drain screws securely.

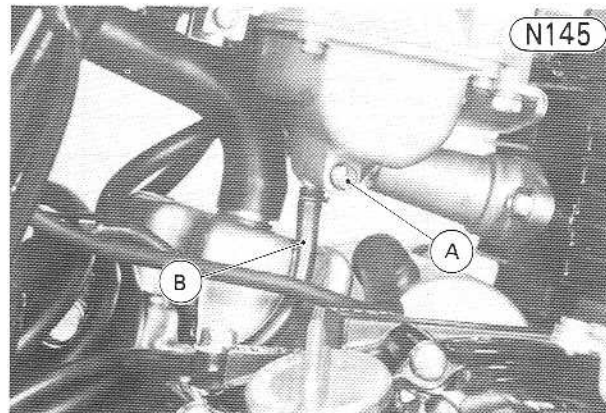

A. Drain Plug
B. Overflow Tube

Cleaning

- Remove the fuel tank, and remove the fuel tap from the tank.
- Flash out the fuel tank with a high flash-point solvent.
- Wash the fuel filter on the fuel tap clean of dirt with a high flash-point solvent.
- Remove the carburetors, and disassemble them to clean the fuel and air passages.

- CAUTION**
1. Remove the floats before cleaning the carburetors with compressed air, or they will be damaged.
 2. Do not use a strong carburetor cleaning solution which could attack rubber or plastic parts; instead, use a mild cleaning solution safe for these parts.
 3. Do not use wire for cleaning as this could damage the jets.

- Wash the disassembled parts, and air and fuel passages with a high flash-point solvent. If necessary, use a bath of automotive type carburetor cleaner.
- Blow the jets, and air and fuel passages clean with compressed air.
- Assemble the disassembled parts, and install the removed parts.

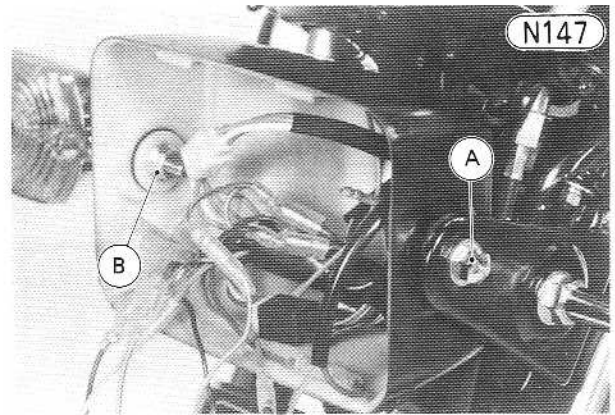

A. Bolt B. Mounting Nut

HEADLIGHT

The headlight beam is adjustable both horizontally and vertically. If not properly adjusted horizontally, the beam will point to one side rather than straight ahead. If adjusted too low vertically, neither low nor high beam will illuminate the road far enough ahead. If adjusted too high vertically, the high beam will fail to illuminate the road close ahead, and the low beam will dazzle oncoming drivers. In most areas it is illegal to ride with improperly adjusted headlight.

Horizontal Adjustment

- Turn the adjusting screw on the headlight rim clockwise or counterclockwise until the beam points straight ahead. Turning the adjusting screw clockwise makes the headlight beam point to the right.

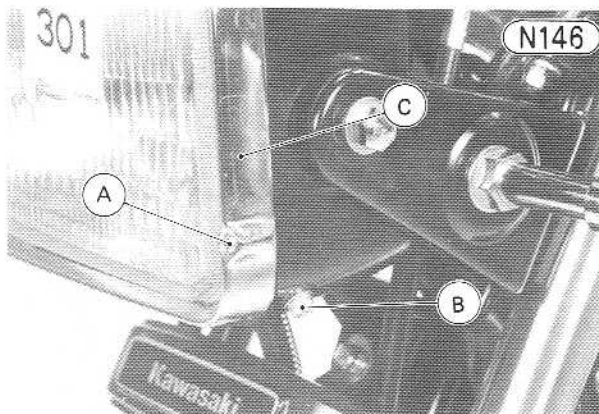

A. Adjusting Screw B. Mounting Screw C. Headlight Unit

Vertical Adjustment

- Remove the mounting screws, and drop out the headlight unit.
- Loosen the headlight housing mounting nuts, and adjust the headlight vertically.

NOTE: On high beam, the brightest point should be slightly below horizontal with the motorcycle on its wheels and the rider seated. Adjust the headlight to the proper angle according to local regulations.

Vertical Adjustment

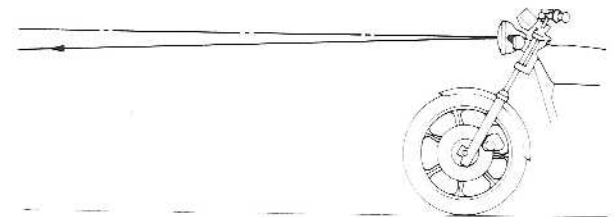

- Tighten the headlight housing mounting nuts.
- Install the headlight unit, and tighten the mounting screws.

FRONT FORK

The front fork can be adjusted to any air pressure within the usable range to suit various riding and load conditions. They can be adjusted to lower air pressure for cruising on smooth roads, but should be adjusted to higher pressure to high speed riding, or riding on bad roads. Before making any adjustments, however, read the procedures in this section.

Air Pressure Inspection

- NOTE:**
1. Check the air pressure when the fork legs are cold.
 2. Do not use tire gauges for checking air pressure. They may not indicate the correct air pressure because of air leaks that occur when the gauge is applied to the valve.

- Put the motorcycle up on its center stand.
- Raise the front wheel off the ground by using a jack under the engine. All weight must be off the front wheel.
- Take off the air valve cap on the top of the front fork.
- Check the air pressure with the air pressure gauge (special tool).

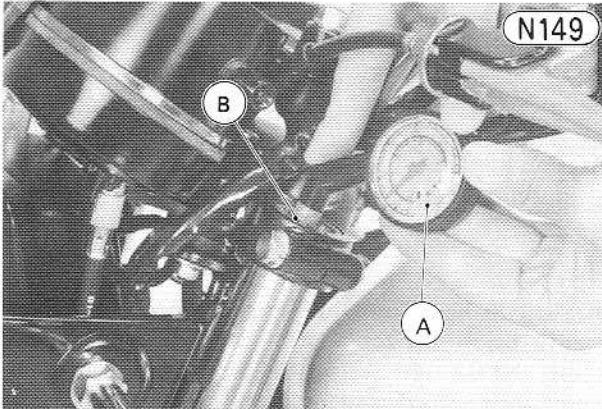

A. Air Pressure Gauge (52005-1003)
B. Air Valve

- Install the air valve cap.
- ★If the air pressure is out of the usable range, adjust it.

Air Pressure Adjustment

- Inject air through the valve with a pump to adjust the pressure within the usable range, but do not exceed 245kPa (2.5kg/cm², 36psi).
- NOTE:** A normal tire pump can be used.

Table N46 Front Fork Air Pressure

| Standard | Usable Range |
|--|---|
| 69 kPa (0.7 kg/cm ² , 10psi) | 59–78 kPa (0.6–0.8 kg/cm ² , 8.5–11psi) |

- CAUTION**
1. Try to set the air pressure of the right and left fork legs as equally as possible. The difference in air pressure between the right and left fork legs must be within 10kPa(0.1 kg/cm², 1.4 psi).
 2. Inject air little by little so that air pressure does not rise rapidly. Air pressure exceeding 245 kPa (2.5kg/cm², 36 psi) may damage the oil seals.

- WARNING**
1. Be sure to adjust the air pressure within the usable range. Front fork adjusted too low or too high adversely affect handling and stability and could lead to accident and injury.
 2. Only air or nitrogen gas can be used. Never inject oxygen or any other kind of gas. Other gases could produce an explosion.
 3. Do not incinerate the front fork.

Disassembly

TORQUE AND LOCKING AGENT

Refer to p.218, noting the following.

1. Apply a non-permanent locking agent to the threads of the front fork air valve, and tighten the valve to 12N-m (1.2 kg-m, 104 in-lb) of torque.
2. Apply a liquid gasket to the threads of the front fork drain bolt.
3. Cross tighten the clutch spring bolts evenly to 8.8N-m (0.9 kg-m, 78 in-lb) of torque.

ENGINE SPROCKET COVER

Removal :

- Remove the mounting bolt and lockwasher, and take off the left footpeg.
- Remove the clamp bolt and take off the shift pedal.
- Remove the screws (4), and pull off the engine sprocket cover.

Installation:

- Make sure that the engine sprocket cover knock pins(2) are in place, and fit the engine sprocket cover.
- Tighten the engine sprocket cover screws (4).
- Install the left footpeg using the bolt and lockwasher.
- Mount the shift pedal with the front of the pedal slightly below the shaft. Insert the bolt and tighten it securely.

CLUTCH RELEASE

Removal :

- Loosen the knurled locknut at the clutch lever, and screw in the adjuster.

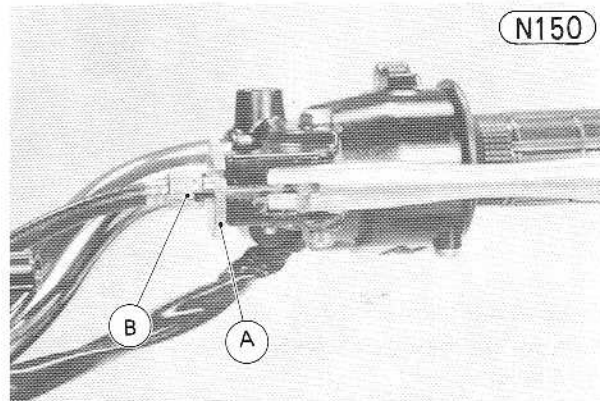

A. Knurled Locknut B. Adjuster

- Slide the dust boot at the clutch cable lower end out of place.
- Loosen the mounting nuts, and slide the lower end of the clutch cable to give the cable plenty of play.
- Remove the cable holder screw from the right engine cover. And then, free the clutch inner cable tip from the clutch release lever.

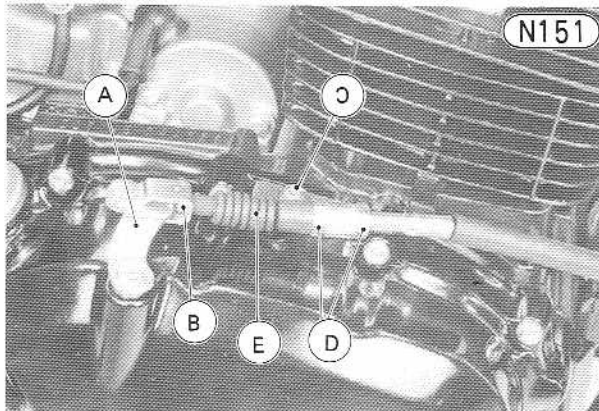

A. Release Lever
 B. Inner Cable Tip
 C. Cable Holder Screw
 D. Mounting Nuts
 E. Dust Boot

- Turn the release lever toward the rear as shown in Fig. N152.

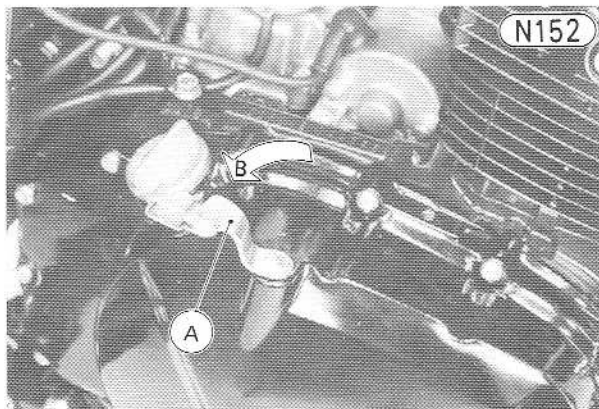

A. Release Lever
 B. Turn toward rear.

- Pull out the clutch release assembly.

Installation Notes:

1. Replace the O-ring that are deteriorated or damaged with a new one.
2. Insert the clutch release shaft so that clutch release lever points rearwards as shown in Fig. N153.

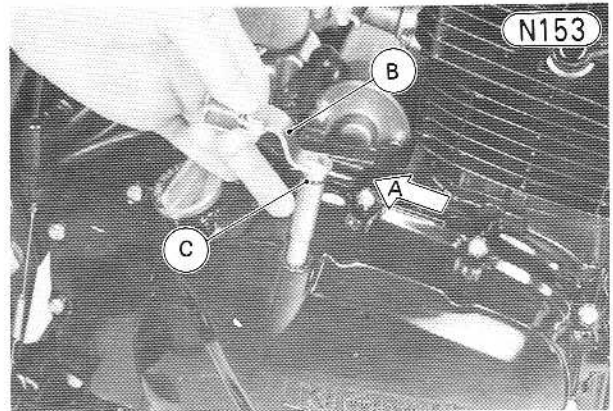

A. Rear
 B. Clutch Release Lever
 C. O-Ring

3. Check and see that the clutch release assembly is installed on the right engine cover with proper angle (about 80°) and clearance between the clutch release lever and the top of the right engine cover as shown in Fig. 154 and 155 when the clutch release lever is fully turned clockwise.

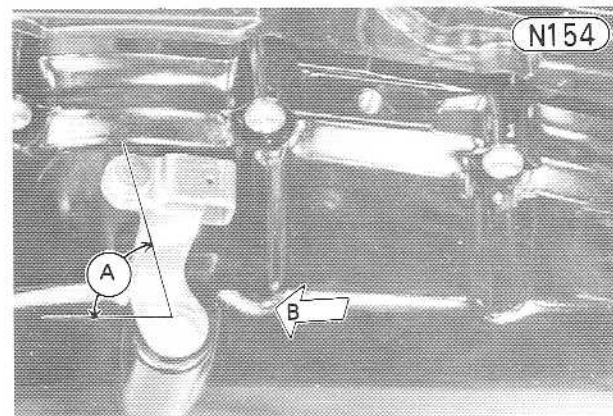

A. About 80°
 B. Rearward

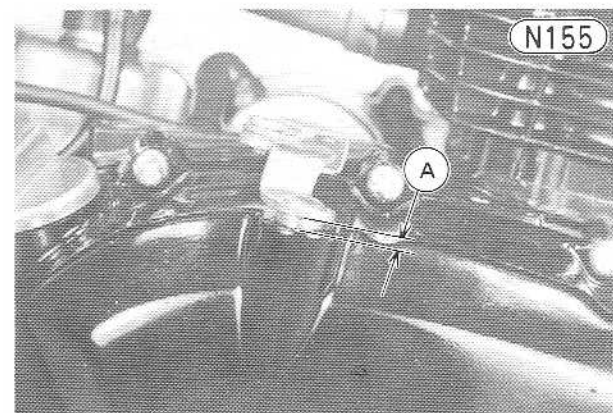

A. 2 ~ 3 mm

4. Check the clutch (p. 270), and adjust it if necessary.

RIGHT ENGINE COVER

Removal:

- With the motorcycle on its center stand, place an oil pan beneath the engine, and remove the engine drain plug to drain out the oil.
- Remove the clutch release assembly (p. 272).
- After draining the oil, insert the drain plug with its gasket and tighten it to 29N-m (3.0kg-m, 22ft-lb) of torque.
- Remove the mounting bolt and lockwasher, and take off the right footpeg.
- Remove the screws (14) and pull off the right engine cover and gasket.

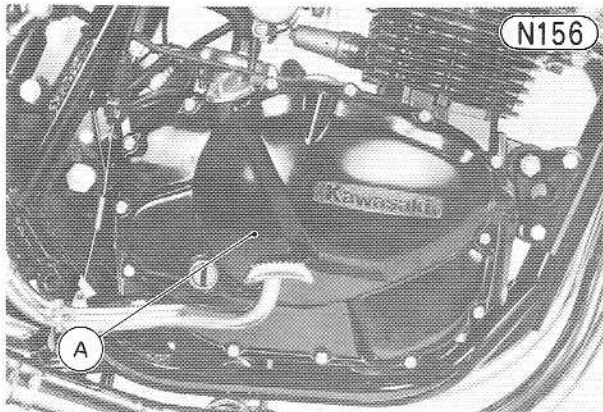

A. Right Engine Cover

Installation:

- Install a new right engine cover gasket.
- Make sure that the two knock pins are in place, and fit the right engine cover on the crankcase.
- Insert the screws (14) and tighten them securely.
- Install the right footpeg, bolt, and lockwasher.
- Install the clutch release assembly (p. 273).
- Fill the engine with correct amount of oil.

CLUTCH

Removal:

- Remove the right engine cover (p. 274).
- Remove the clutch spring bolts (14), washers (14), and springs (13) (5 ea).

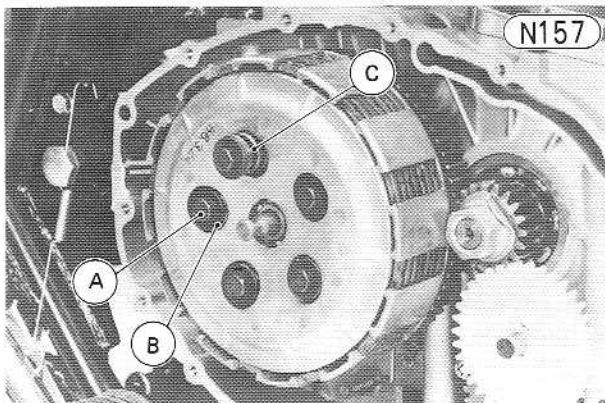

A. Bolt B. Washer C. Spring

- Remove the spring plate (12), ball bearing (11), and spring plate pusher (10).

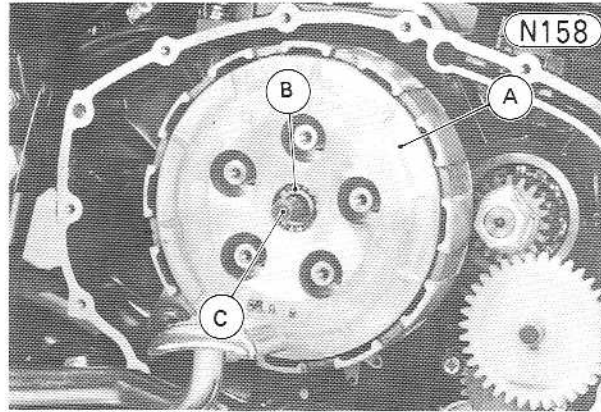

A. Spring plate C. Spring plate Pusher
B. Ball Bearing

- Remove the friction plates (6) (7) and steel plate (7) (6).
- Straighten the part of the toothed washer (8) that is bent over the side of the clutch hub nut (9).
- Using the clutch holder (special tool) to hold the clutch hub steady, loosen the clutch hub nut, and remove the clutch hub nut and toothed washer.

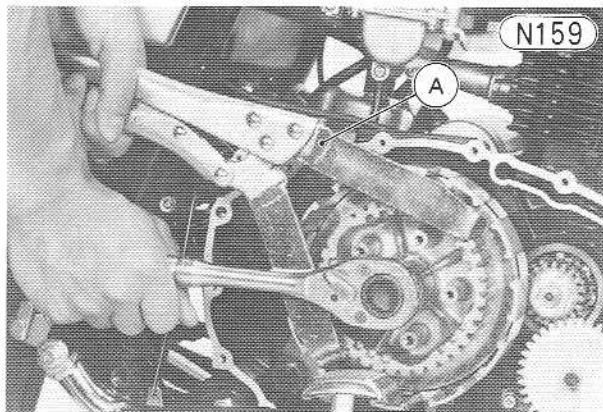

A. Clutch Holder (57001-305)

- Pull off the clutch hub (5), thrust washer (4), clutch housing (3), sleeve (2), and spacer (1).

Installation:

- Pull the spacer and sleeve on the drive shaft.
- Apply engine oil to the clutch gear and in the clutch housing hub.
- Fit the clutch housing so that the clutch housing gear meshes with the primary gear.
- Put on the thrust washer and clutch hub.
- Put on the toothed washer so that its tooth fits into the hole in the clutch hub. Screw on the clutch hub nut.

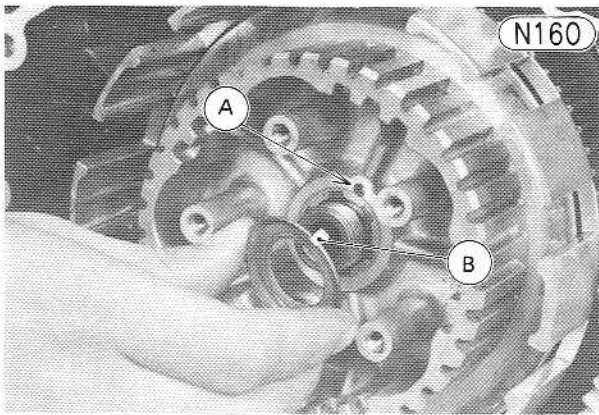

N160

A. Hole

B. Tooth

- Tighten the clutch hub nut to 120N-m (12.0 kg-m, 87ft-lb) of torque, using the clutch hub holder (special too) to hold the clutch hub steady.
- Bend the part of toothed washer over the side of the clutch hub nut.

- Fit the friction plates (7) and steel plates (6), starting with a friction plate and alternating them. The friction plates should be installed so that the grooves run toward the center in the direction of the clutch housing rotation (counterclockwise viewed from the right side of the engine, see Fig. N2 on p.184).

CAUTION If the new dry plates are used, apply engine oil to the plates to avoid clutch plate seizure.

- Apply a small amount of molybdenum disulfide grease to the spring plate pusher, and fit it into the drive shaft.
- Fit the ball bearing onto the spring plate.
- Install the spring plate, springs, washers, and bolts (5 ea). Crosstighten the bolts evenly to 8.8 N-m (0.9 kg-m, 78 in-lbs) of torque.
- Install the right engine cover (p. 274).
- Adjust the clutch (p. 270).

Clutch

N161

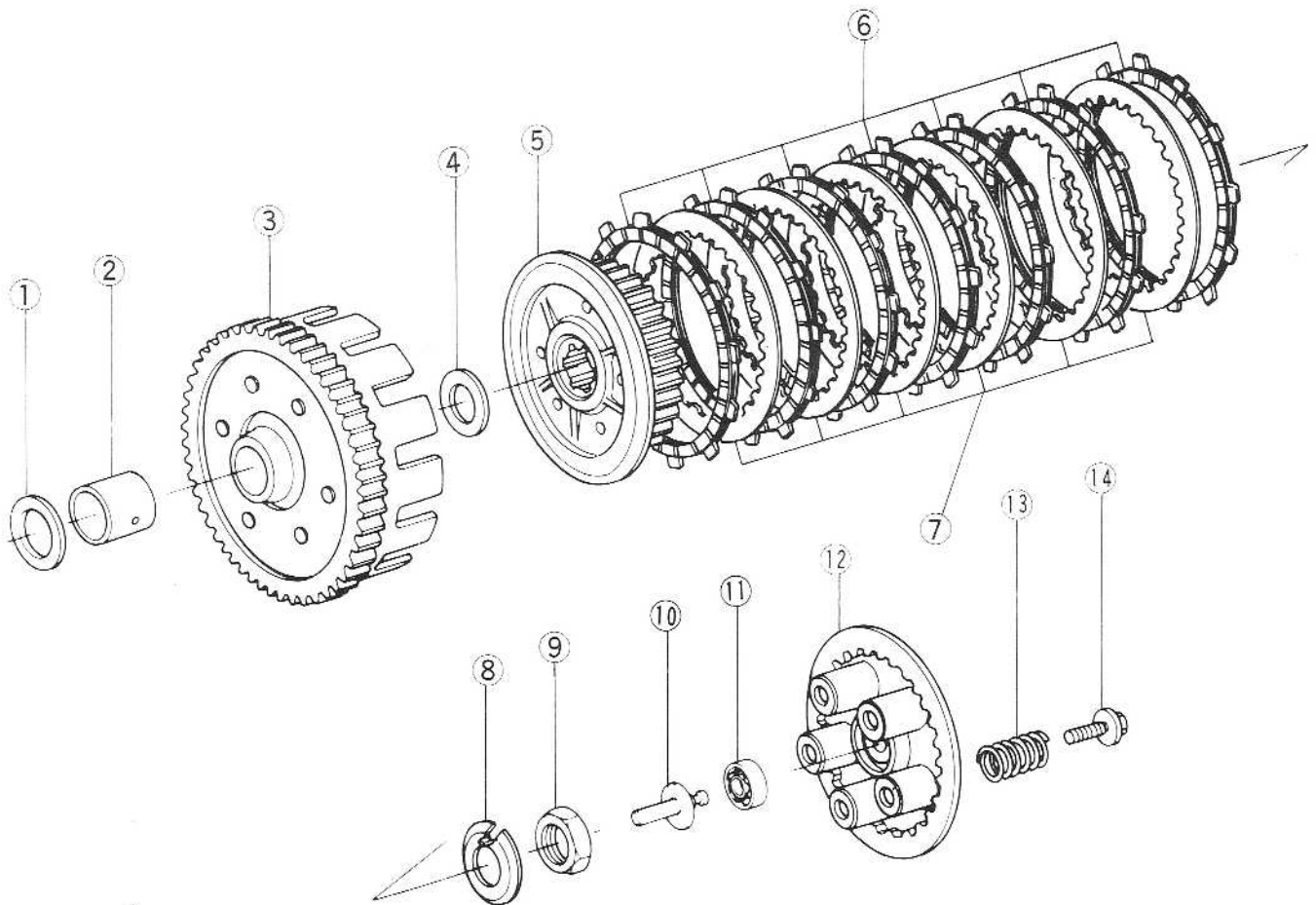

- 1. Spacer
- 2. Sleeve
- 3. Clutch Housing
- 4. Thrust Washer
- 5. Clutch Hub

- 6. Friction Plates
- 7. Steel Plates
- 8. Toothed Washer
- 9. Nut
- 10. Spring Plate Pusher

- 11. Ball Bearing
- 12. Spring Plate
- 13. Spring
- 14. Bolt and Washer

FRONT FORK

The front fork for the 1982 model is an air adjustable front fork. The removal and installation procedures are the same as those for the 1979 Z250-A1, and the disassembly and assembly procedures are the same as those for the 1979 Z250-A1 with the following exceptions. Refer to p.110.

1. Release the air through the air valve at the top of the inner tube before disassembling the fork leg.
2. Apply a liquid gasket to the threads of the drain bolt.
3. Refill with 154 cc of fresh SAE5W20 oil, and check the fork oil level (p. 276).
4. Apply a non-permanent locking agent to the threads of the air valve, and tighten the valve to 12N-m (1.2 kg-m, 104 in-lb) of torque when assembling the fork leg.
5. Inject air through the air valve after assembling the fork leg, and check the air pressure (p. 271).

Maintenance

FRONT FORK

The front fork legs of the 1982 model contain compressed air to obtain adjustable suspension. This type of the front fork is especially effective when the fork is compressed. It also has the advantage that any air pressure can be chosen (within the usable range) to suit various riding conditions.

WARNING Do not remove the springs and rely on compressed air only. Correct springs must be used in this suspension system. Use without springs can lead to a condition causing accident and injury.

The maintenance prodedures for the 1982 Z250-A4 air adjustable front fork are the same as those for the 1979 Z250-A1 with the following exceptions. Refer to p.p. 151-152.

Fork Oil Change

1. The front fork oil capacity and level for the 1982 model are shown in Table N47.
2. Adjust the air pressure after changing oil (p. 271).

Table N47 Fork Oil

| Type | Filling fork oil capacity | | Oil level (mm) |
|----------|---------------------------|--------------------------------------|--------------------------------|
| | When changing oil | After disassembly and completely dry | |
| SAE 5W20 | about 135 mL | 151.5 — 156.5 mL | 426 ± 2 from top of inner tube |

Spring Tension

1. The front fork spring free length for the 1982 model is shown in Table N48.

Table N48 Fork Spring Length

| Standard | Service Limit |
|----------|---------------|
| 478.5 mm | 469 mm |

Appendix

SPECIAL TOOLS

The special tools for the 1982 Z250-A4 are the same as those for the 1981 Z250-A3 with the following exceptions. Refer to p.233.

1. Use the new vacuum gauge (P/N:57001-1152) to synchronize the carburetors.

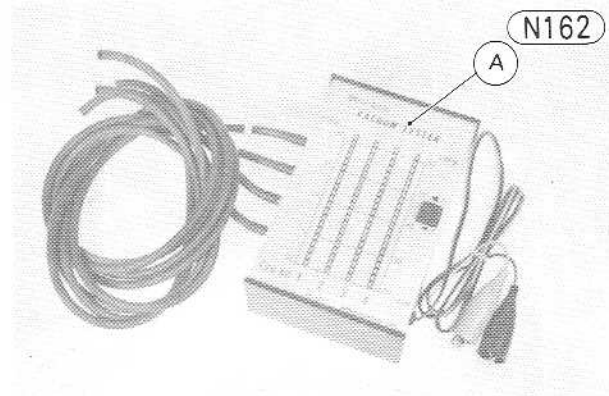

A. Vacuum Gauge (57001-1152)

2. Use the air pressure gauge (P/N: 52005-1003) to check the front fork air pressure.

N163

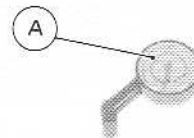

A. Air Pressure Gauge (52005-1003)

WIRING DIAGRAMS

The wiring diagrams for the 1982 Z250-A4 are shown on p.p. 277-278.

Z250-A4,B3 Wiring Diagram (European Model except West German Model)

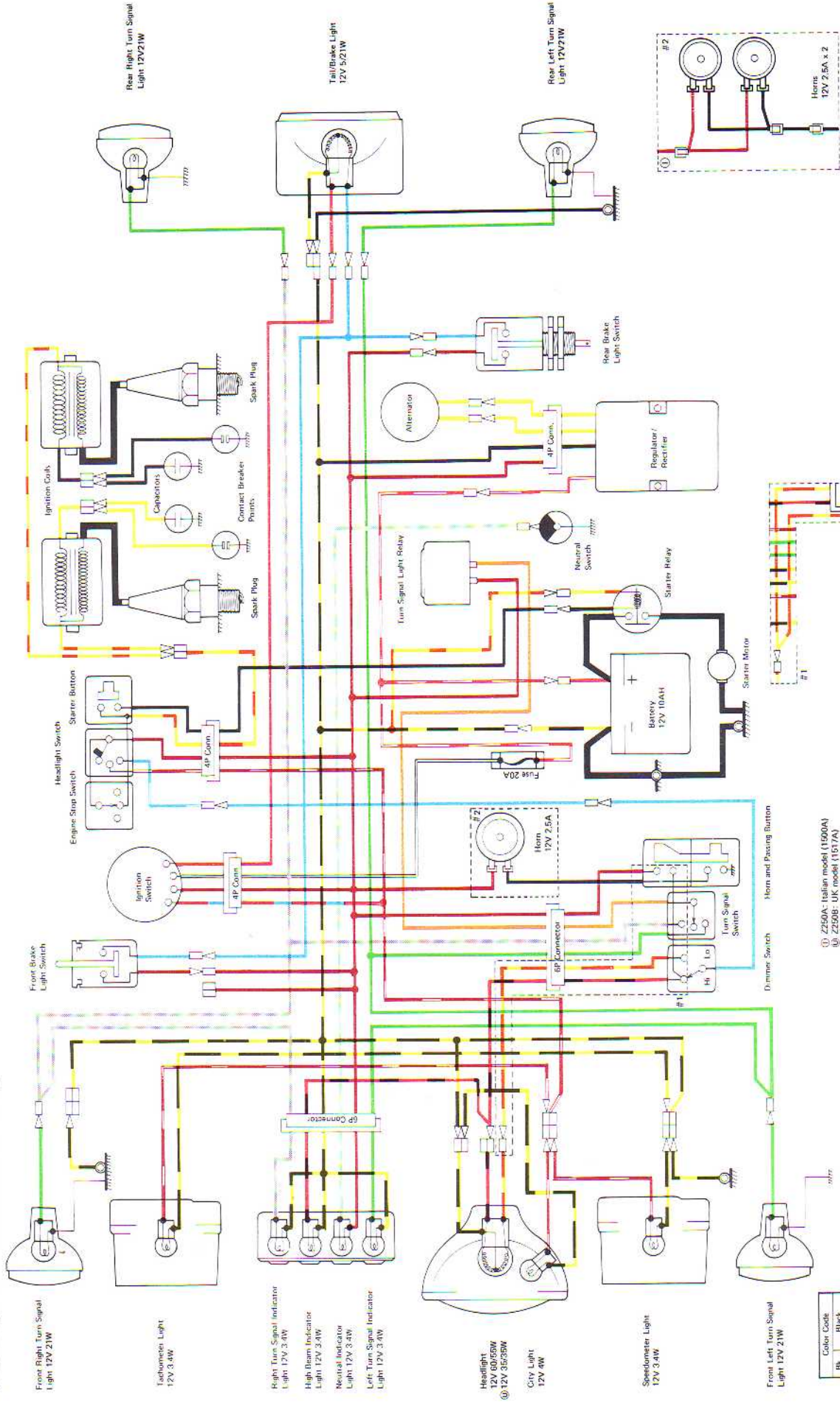

Front Right Turn Signal Light 12V 21W

Tachometer Light 12V 3.4W

Right Turn Signal Indicator Light 12V 3.4W

High Beam Indicator Light 12V 3.4W

Neutral Indicator Light 12V 3.4W

Left Turn Signal Indicator Light 12V 3.4W

Headlight 12V 60/55W @ 12V 35/35W

City Light 12V 4W

Speedometer Light 12V 3.4W

Front Left Turn Signal Light 12V 21W

| Color Code | Color |
|------------|-------------|
| BK | Black |
| BL | Blue |
| BR | Brown |
| GR | Green |
| GY | Gray |
| LG | Light Green |
| OR | Orange |
| RD | Red |
| WH | White |
| YL | Yellow |

LEFT HANDLEBAR SWITCH CONNECTIONS

| Color | Dimmer Switch | Turn Signal Switch | Horn Button | Passing Button |
|-------|---------------|--------------------|-------------|----------------|
| RBK | OFF | R | Black | Brown |
| BL | ON | L | Push | Push |
| GR | | | | |

IGNITION SWITCH CONNECTIONS

| Color | ON | OFF | LOCK (P/PARK) |
|-------|----------|--------|---------------|
| White | Ignition | Tail 7 | |
| Brown | R/BI | R/BI | |
| Red | | | |

RIGHT HANDLEBAR SWITCH CONNECTIONS

| Color | Y/R | Color | Headlight Switch | Starter Button |
|-------|-----|-------|------------------|----------------|
| OFF | OFF | PO | OFF | Push |
| RUN | ON | | | |
| OFF | | | | |

① Z250A: Italian model (1500A)
② Z250B: UK model (1517A)

(1495A)

**Z250-A4,B3 Wiring Diagram
(General Export Model)**

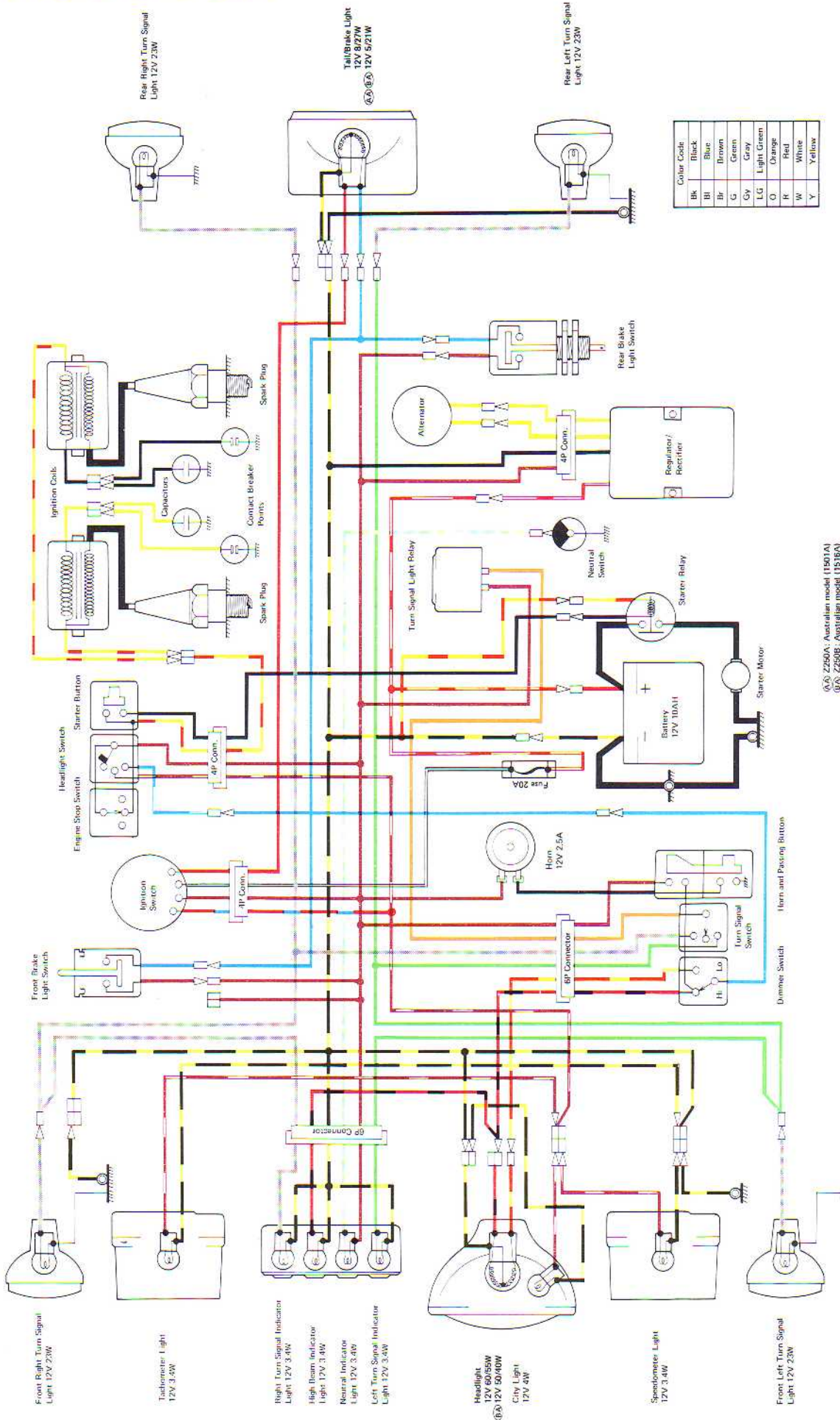

RIGHT HANDLEBAR SWITCH CONNECTIONS

| | | | |
|--------------------|-------|-------|-------|
| Engine Stop Switch | Color | Brown | Y/R |
| Headlight Switch | Color | Brown | Br/W |
| Starter Button | Color | Y/R | Black |
| Push | Color | Push | Push |
| ON | Color | ON | ON |
| OFF | Color | OFF | OFF |
| RUN | Color | RUN | RUN |

IGNITION SWITCH CONNECTIONS

(A) Z250A: Australian model (1501A)
(B) Z250B: Australian model (1516A)

| | | | | | | | |
|---------|-------|----------|-------|---------|---------|---------|---------|
| Battery | White | Ignition | Brown | Tail 1 | Red | Tail 2 | Red |
| ON | White | ON | Br/R | LOCK | LOCK | LOCK | LOCK |
| OFF | OFF | OFF | OFF | PIP/ATK | PIP/ATK | PIP/ATK | PIP/ATK |

LEFT HANDLEBAR SWITCH CONNECTIONS

| | | | | | | | |
|--------------------|-------|------|------|----------------|-------|-------|------|
| Dimmer Switch | Color | H/Bk | Bl | Horn Button | Color | Black | Br/W |
| Turn Signal Switch | Color | R/Y | G | Passing Button | Color | Brown | R/Bk |
| Push | Color | Push | Push | Push | Color | Push | Push |
| ON | Color | ON | ON | ON | Color | ON | ON |
| OFF | Color | OFF | OFF | OFF | Color | OFF | OFF |
| R | Color | R | R | L | Color | L | L |
| L | Color | L | L | Hi | Color | Hi | Hi |
| Hi | Color | Hi | Hi | Lo | Color | Lo | Lo |
| Lo | Color | Lo | Lo | | Color | | |

11498A

Supplement for 1982 Z250-B3

Table of Contents

| | |
|----------------------------------|-----|
| MODEL IDENTIFICATION | 280 |
| SPECIFICATIONS | |
| SPECIFICATIONS | 282 |
| PERIODIC MAINTENANCE CHART | 282 |
| ADJUSTMENT | |
| CLUTCH | 282 |
| FUEL SYSTEM | 282 |
| DISASSEMBLY | |
| TORQUE AND LOCKING AGENT | 282 |
| ENGINE SPROCKET COVER | 282 |
| CLUTCH RELEASE | 282 |
| RIGHT ENGINE COVER | 282 |
| CLUTCH | 282 |
| APPENDIX | |
| SPECIAL TOOLS | 282 |
| WIRING DIAGRAMS | 282 |

Model Identification

Z250-B3 Left Side View



Z250-B3 Right Side View



PERIODIC MAINTENANCE CHART (Z250-B3)

The maintenance and adjustments must be done in accordance with this chart to keep the motorcycle in good running condition. The initial maintenance is vitally important and must not be neglected.

| OPERATION | FREQUENCY | ODOMETER READING* | | | | | | | See Page |
|--|----------------------------|-------------------|----------|-----------|-----------|-----------|-----------|-----------|----------|
| | Whichever comes first ↓ | 800 km | 5,000 km | 10,000 km | 15,000 km | 20,000 km | 25,000 km | 30,000 km | |
| Engine oil – change | Every year | • | • | • | • | • | • | • | 22 |
| Oil filter – replace | | • | | • | | • | | • | 22 |
| Fuel system – clean | | | | • | | • | | • | 282 |
| Fuel hose – replace | 4 years | | | | | | | | – |
| Spark plug – clean and gap † | | • | • | • | • | • | • | • | 12 |
| Ignition timing – check † | | • | • | • | • | • | • | • | 238 |
| Timing advancer – lubricate | | | | • | | • | | • | 162 |
| Valve clearance – check † | | • | • | • | • | • | • | • | 16 |
| Air cleaner element – clean | | | • | | • | | • | | 115 |
| Air cleaner element – replace | 5 cleanings | | | • | | • | | • | 115 |
| Throttle grip play – check † | | • | • | • | • | • | • | • | 238 |
| Idle speed – check † | | • | • | • | • | • | • | • | 18 |
| Carburetor synchronization – check † | | • | • | • | • | • | • | • | 19 |
| Clutch – adjust | | • | • | • | • | • | • | • | 282 |
| Drive chain wear – check † | | | • | • | • | • | • | • | 144 |
| Drive chain – lubricate | 300 km | | | | | | | | 144 |
| Drive chain slack – check † | 800 km | | | | | | | | 24 |
| Brake lining wear – check † | | | • | • | • | • | • | • | 209 |
| Brake camshaft – lubricate | 2 years | | | | | • | | | 210 |
| Brake cable – replace | 2 years | | | | | | | | 198 |
| Brake play – check † | | • | • | • | • | • | • | • | 192 |
| Brake light switch – check † | | • | • | • | • | • | • | • | 26 |
| Steering play – check † | | • | • | • | • | • | • | • | 26 |
| Steering stem bearing – lubricate | 2 years | | | | | • | | | 150 |
| Front fork oil – change | | | | • | | • | | • | 152 |
| Front fork oil seal – clean | | | • | • | • | • | • | • | 151 |
| Tire wear – check † | | | • | • | • | • | • | • | 140 |
| Wheel bearing – lubricate | 2 years | | | | | • | | | 143 |
| Speedometer gear – lubricate | 2 years | | | | | • | | | 209 |
| Spoke tightness and rim runout—check † | | • | • | • | • | • | • | • | 207 |
| Swing arm pivot – lubricate | | | | • | | • | | • | 238 |
| Battery electrolyte level – check † | month | • | • | • | • | • | • | • | 156 |
| General lubrication – perform | | | • | • | • | • | • | • | 195 |
| Nut,bolt,and fastener tightness—check† | | • | | • | | • | | • | 282 |

* For higher odometer readings, repeat at the frequency interval established here.

† Replace, add, adjust or torque if necessary.

Specifications

SPECIFICATIONS

The specifications for the 1982 Z250-B3 are shown on p. 267.

PERIODIC MAINTENANCE CHART

The Periodic Maintenance Chart for the 1982 Z250-B3 is shown on p. 281.

Appendix

SPECIAL TOOLS

The special tools for the 1982 Z250-B3 are the same as those for the 1981 Z250-A3 with the following exception Refer to p. 233.

1. Use the new vacuum gauge (P/N: 57001-1152) to synchronize the carburetors. (See Fig. N162 on p. 276.)

WIRING DIAGRAMS

The wiring diagrams for the 1982 Z250-B3 are shown on p.p. 277–278.

Adjustment

The adjustment procedures for the following two items are the same as those for the 1982 Z250-A4. Refer to the supplement for the 1982 Z250-A4.

- CLUTCH (p. 270)
- FUEL SYSTEM (p. 270)

Disassembly

TORQUE AND LOCKING AGENT

Refer to p.238, noting the following.

1. Cross tighten the clutch spring bolts to 8.8N-m (0.9 kg-m, 78 in-lb) of torque.

The disassembly and assembly procedures for the following four items are the same as those for the 1982 Z250-A4. Refer to the supplement for the 1982 Z250-A4.

- ENGINE SPROCKET COVER (See p. 272)
- CLUTCH RELEASE (See p. 272)
- RIGHT ENGINE COVER (See p. 274)
- CLUTCH (See p. 274)

Supplement for 1982 KZ305-A2

Table of Contents

| | |
|----------------------------------|-----|
| MODEL IDENTIFICATION | 284 |
| SPECIFICATIONS | |
| SPECIFICATIONS | 285 |
| PERIODIC MAINTENANCE CHART | 287 |
| ADJUSTMENT | |
| CLUTCH | 288 |
| DISASSEMBLY | |
| TORQUE AND LOCKING AGENT | 288 |
| ENGINE SPROCKET COVER | 288 |
| CLUTCH RELEASE | 288 |
| RIGHT ENGINE COVER | 288 |
| CLUTCH | 288 |
| MAINTENANCE | |
| CARBURETORS | 288 |
| APPENDIX | |
| SPECIAL TOOLS | 288 |

Model Identification

KZ305-A2 Left Side View



KZ305-A2 Right Side View



Specifications

SPECIFICATIONS

| | KZ305-A2 (U.S. model) | KZ305-B1 (U.S. model) | KZ305-D1 (Canadian model) |
|---------------------------|--|--------------------------|---------------------------------|
| Dimensions | | | |
| Overall length | 2,030 mm | * | * |
| Overall width | 815 mm | 820 mm | ** |
| Overall height | 1,150 mm | * | * |
| Wheelbase | 1,355 mm | 1,365 mm | ** |
| Road clearance | 150 mm | * | * |
| Seat height | 750 mm | * | * |
| Dry weight | 152 kg | 153 kg | 154 kg |
| Fuel tank capacity | 10.5 L | * | * |
| Performance | | | |
| Climbing ability | 27° | * | * |
| Braking distance | 12.5 m from 50 km/h | * | * |
| Minimum turning radius | 2.3 m | * | * |
| Engine | | | |
| Type | SHOC, 2-cylinder, 4-stroke | * | * |
| Cooling system | Air-cooled | * | * |
| Bore and stroke | 61.0 x 52.4 mm | * | * |
| Displacement | 0.306 L | * | * |
| Compression ratio | 9.5 | * | * |
| Maximum horsepower | 30 HP @9,000 r/min (rpm) | * | * |
| Maximum torque | 25N-m(2.5 kg-m) @7,000 r/min (rpm) | * | * |
| Valve timing | | | |
| Inlet | Open | 21° BTDC | * |
| | Close | 59° ABDC | * |
| | Duration | 260° | * |
| Exhaust | Open | 61° BBDC | * |
| | Close | 19° ATDC | * |
| | Duration | 260° | * |
| Carburetors | Keihin CV32 x 2 | * | * |
| Lubrication system | Forced lubrication (wet sump.) | * | * |
| Engine oil: Grade | SE class | * | * |
| Viscosity | SAE 10W 40, 10W 50, 20W 40, or 20W 50 | * | * |
| Capacity | 1.8L, 1.5L (without filter change) | * | * |
| Starting system | Electric starter | * | * |
| Ignition system | Battery and coil | * | * |
| Ignition timing | From 10° BTDC @1,250 r/min (rpm) | * | * |
| (Mechanically advanced) | to 40° BTDC 2,500 r/min (rpm) | * | * |
| Spark plugs | NGK D9EA | * | NGK DR8ES or ND X 24ERS-U |
| Drive Train | | | |
| Primary reduction system: | | | |
| Type | Gear | * | * |
| Reduction ratio | 3.736 (71/19) | * | * |
| Clutch type | Wet, multi disc | * | * |
| Transmission: | | | |
| Type | 6-speed, constant mesh, return shift | * | * |
| Gear ratios 1st | 2.600 (39/15) | * | * |
| 2nd | 1.789 (34/19) | * | * |

| | | | | |
|----------------------------|---------------------|--------------------------------------|----------------------|----|
| | 3rd | 1.409 (31/22) | * | * |
| | 4th | 1.160 (29/25) | * | * |
| | 5th | 1.000 (27/27) | * | * |
| | 6th | 0.892 (25/28) | * | * |
| Final drive system: | | | | |
| | Type | Chain | Belt | ** |
| | Reduction ratio | 2.200 (33/15) | 2.173 (50/23) | ** |
| | Overall drive ratio | 7.340 (@ Top gear) | 7.253 (@Top gear) | ** |
| Electric Equipment | | | | |
| | Alternator: Type | Single-phase AC | * | * |
| | Rated output | 13.5 amp. @8,000 r/min (rpm), 14V | * | * |
| | Voltage regulator | Open-circuit type | * | * |
| | Battery | 12V 10AH | * | * |
| | Headlight: Type | Sealed beam | * | * |
| | Bulb | 12V 50/35W | * | * |
| | Tail/Brake light | 12V 8/27W | * | * |
| Frame | | | | |
| | Type | Tubular, single cradle | * | * |
| | Steering angle | 40° to either side | * | * |
| | Caster (rake angle) | 28.5° | * | * |
| | Trail | 106 mm | * | * |
| | Tire size Front | 3.00S—18 4PR | * | * |
| | Rear | 120/90—16 63S | * | * |
| | Suspension: Front | Telescopic fork | * | * |
| | Rear | Swing arm | * | * |
| | Wheel travel:Front | 150 mm | * | * |
| | Rear | 105 mm | * | * |
| Brakes | | | | |
| | Type: Front | Single disc brake | * | * |
| | Rear | Internal expansion, leading-trailing | * | * |

* : Identical to KZ305-A2 **: Identical to KZ305-B1

Specifications subject to change without notice.

PERIODIC MAINTENANCE CHART (KZ305-A2)

The maintenance and adjustments must be done in accordance with this chart to keep the motorcycle in good running condition. The initial maintenance is vitally important and must not be neglected.

| OPERATION | FREQUENCY | ODOMETER READING* | | | | | | | See Page |
|---|-------------|-----------------------|--------|----------|-----------|-----------|-----------|-----------|----------|
| | | Whichever comes first | 800 km | 5,000 km | 10,000 km | 15,000 km | 20,000 km | 25,000 km | |
| Engine oil — change | Every year | • | • | • | • | • | • | • | 22 |
| Oil filter — replace | | • | | • | | • | | • | 22 |
| Fuel system — clean | | | | • | | • | | • | 245 |
| Fuel hose — replace | 4 years | | | | | | | | — |
| Spark plug — clean and gap † | | • | • | • | • | • | • | • | 245 |
| Ignition timing — check † | | • | • | • | • | • | • | • | 245 |
| Timing advancer — lubricate | | | | • | | • | | • | 162 |
| Valve clearance — check † | | • | • | • | • | • | • | • | 16 |
| Air cleaner element — clean | | | • | | • | | • | | 115 |
| Air cleaner element —replace | 5 cleanings | | | • | | • | | • | 115 |
| Throttle grip play — check † | | • | • | • | • | • | • | • | 245 |
| Idle Speed — check † | | • | • | • | • | • | • | • | 245 |
| Carburetor Synchronization — check† | | • | • | • | • | • | • | • | 19 |
| Clutch — adjust | | • | • | • | • | • | • | • | 288 |
| Drive chain wear — check † | | | • | • | • | • | • | • | 144 |
| Drive chain — lubricate | 300 km | | | | | | | | 144 |
| Drive chain slack — check † | 800 km | | | | | | | | 24 |
| Brake lining wear — check † | | | • | • | • | • | • | • | 254 |
| Brake fluid level — check † | month | • | • | • | • | • | • | • | 254 |
| Brake fluid — change | year | | | • | | • | | • | 254 |
| Brake hose — replace | 4 years | | | | | | | | 254 |
| Caliper piston seal and dust seal—replace | 2 years | | | | | | | | 254 |
| Master cylinder cup and dust seal—replace | 2 years | | | | | | | | 254 |
| Brake camshaft — lubricate | 2 years | | | | | • | | | 254 |
| Brake play — check † | | • | • | • | • | • | • | • | 245 |
| Brake light switch — check † | | • | • | • | • | • | • | • | 26 |
| Steering play — check † | | • | • | • | • | • | • | • | 26 |
| Steering stem bearing — lubricate | 2 years | | | | | • | | | 150 |
| Front fork oil — change | | | | • | | • | | • | 152 |
| Front fork oil seal — clean | | | • | • | • | • | • | • | 151 |
| Tire wear — check † | | | • | • | • | • | • | • | 251 |
| Wheel bearing — lubricate | 2 years | | | | | • | | | 253 |
| Speedometer gear — lubricate | 2 years | | | | | • | | | 253 |
| Spoke tightness and rim runout—check † | | • | • | • | • | • | • | • | 252 |
| Swing arm pivot — lubricate | | | | • | | • | | • | 245 |
| Battery electrolyte level — check † | month | • | • | • | • | • | • | • | 156 |
| General lubrication — perform | | | • | • | • | • | • | • | 245 |
| Nut,bolt,and fastener tightness — check † | | • | • | • | • | • | • | • | 288 |

* For higher odometer readings, repeat at the frequency interval established here.

† Replace, add, adjust or torque if necessary.

Adjustment

CLUTCH

The adjustment procedures are the same as those for the 1982 Z250-A4. Refer to p. 270.

Disassembly

TORQUE AND LOCKING AGENT

Refer to p.246, noting the following.

1. Cross tighten the clutch spring bolts evenly to 8.8N-m (0.9 kg-m, 78 in-lb) of torque.

The disassembly and assembly procedures for the following four items are the same as those for the 1982 Z250-A4. Refer to the supplement for the 1982 Z250-A4.

- ENGINE SPROCKET COVER (See p. 272)
- CLUTCH RELEASE (See p. 272)
- RIGHT ENGINE COVER (See p. 274)
- CLUTCH (See p. 274)

Maintenance

CARBURETORS

Refer to p.250, noting the following.

High Altitude Performance Adjustment for U.S. Model:

To improve the EMISSION CONTROL PERFORMANCE of vehicles operated above 4,000 feet, Kawasaki recommends the following Environmental Protection Agency (EPA) approved modification.

NOTE: When properly performed, these specified modifications only, are not considered to be emission system "tampering" and vehicle performance is generally unchanged as a result.

High Altitude Performance Adjustment

High altitude adjustment requires replacement of the main and pilot jets.

Table N49 High Altitude Carburetor Specifications

| Pilot Jet | Main Jet |
|-----------|----------|
| # 32 | #82 |

Appendix

SPECIAL TOOLS

The special tools for the 1982 KZ305-A2 are the same as those for the 1981 KZ305-A1 with the following exception. Refer to p.254.

1. Use the new vacuum gauge (P/N: 57001-1152) to synchronize the carburetors. (See Fig. N162 on p. 276.)

Supplement for 1982 KZ305-B1

NOTE: The maintenance and repair procedures for the KZ305B are newly included in this section. Unless otherwise noted, procedures for the 1982 KZ305-B1 are the same as those for their standard model 1979 Z250-A1.

Table of Contents

| | |
|---|-----|
| MODEL IDENTIFICATION | 290 |
| SPECIFICATIONS | |
| SPECIFICATIONS | 292 |
| PERIODIC MAINTENANCE CHART | 292 |
| ADJUSTMENT | |
| IGNITION TIMING | 292 |
| CAMSHAFT CHAIN | 292 |
| THROTTLE CABLE | 292 |
| REAR SHOCK ABSORBERS | 292 |
| LUBRICATION | 292 |
| SPARK PLUGS | 292 |
| CARBURETORS | 292 |
| FUEL SYSTEM | 292 |
| BRAKES | 292 |
| WHEEL BALANCE | 292 |
| HEADLIGHT | 292 |
| CLUTCH | 292 |
| DRIVE BELT | 292 |
| DISASSEMBLY | |
| TORQUE AND LOCKING AGENT | 294 |
| CARBURETORS | 294 |
| CAMSHAFT CHAIN TENSIONER | 294 |
| PISTON, PISTON RINGS | 294 |
| TRANSMISSION | 294 |
| CYLINDER HEAD COVER, ROCKER ARM | 294 |
| FRONT WHEEL | 294 |
| FRONT BRAKE | 294 |
| RIM | 294 |
| SPOKES | 294 |
| ENGINE PULLEY COVER | 294 |
| CLUTCH RELEASE | 294 |
| RIGHT ENGINE COVER | 294 |
| CLUTCH | 294 |
| ENGINE PULLEY | 295 |
| EXTERNAL SHIFT MECHANISM | 295 |
| DRIVE BELT | 295 |
| REAR WHEEL, BRAKE | 296 |
| MAINTENANCE | |
| ROCKER ARMS, SHAFTS | 297 |
| CAMSHAFT | 297 |
| CAMSHAFT CHAIN, GUIDES, TENTIONER | 297 |
| CYLINDER HEAD, VALVES | 297 |
| SWING ARM | 297 |
| IGNITION SYSTEM | 297 |
| CYLINDER BLOCK, PISTONS | 297 |
| TRANSMISSION | 297 |
| WHEELS | 297 |
| BRAKES | 297 |
| SPARK PLUGS | 297 |
| CARBURETORS | 297 |
| PULLEYS | 297 |
| APPENDIX | |
| SPECIAL TOOLS | 298 |
| WIRING DIAGRAM | 298 |

Model Identification

KZ305-B1 Left Side View



KZ305-B1 Right Side View



PERIODIC MAINTENANCE CHART (KZ305-B1)

The maintenance and adjustments must be done in accordance with this chart to keep the motorcycle in good running condition. The initial maintenance is vitally important and must not be neglected.

| OPERATION | FREQUENCY | Whichever comes first ↓ | ODOMETER READING* | | | | | | | See Page |
|---|-------------|----------------------------|-------------------|----------|-----------|-----------|-----------|-----------|-----------|----------|
| | | | 800 km | 5,000 km | 10,000 km | 15,000 km | 20,000 km | 25,000 km | 30,000 km | |
| Engine oil – change | Every year | • | • | • | • | • | • | • | • | 22 |
| Oil filter – replace | | • | | • | | • | | • | | 22 |
| Fuel system – clean | | | | • | | • | | • | | 292 |
| Fuel hose – replace | 4 years | | | | | | | | | — |
| Spark plug – clean and gap † | | • | • | • | • | • | • | • | • | 292 |
| Ignition timing – check † | | • | • | • | • | • | • | • | • | 292 |
| Timing advancer – lubricate | | | | • | | • | | • | | 162 |
| Valve clearance – check † | | • | • | • | • | • | • | • | • | 16 |
| Air cleaner element – clean | | | • | | • | | • | | | 115 |
| Air cleaner element – replace | 5 cleanings | | | • | | • | | • | | 115 |
| Throttle grip play – check † | | • | • | • | • | • | • | • | • | 292 |
| Idle speed – check † | | • | • | • | • | • | • | • | • | 292 |
| Carburetor synchronization – check † | | • | • | • | • | • | • | • | • | 292 |
| Clutch – adjust | | • | • | • | • | • | • | • | • | 292 |
| Drive belt tension – check † | | • | • | • | • | • | • | • | • | 292 |
| Drive belt wear – check † | | • | • | • | • | • | • | • | • | 294 |
| Brake lining wear – check † | | | • | • | • | • | • | • | • | 297 |
| Brake fluid level – check † | month | • | • | • | • | • | • | • | • | 297 |
| Brake fluid – change | year | | | • | | • | | • | | 297 |
| Brake hose – replace | 4 years | | | | | | | | | 297 |
| Master cylinder cup and dust seal—replace | 2 years | | | | | | | | | 297 |
| Caliper piston seal and dust seal – replace | 2 years | | | | | | | | | 297 |
| Brake camshaft – lubricate | 2 years | | | | | • | | | | 297 |
| Brake play – check † | | • | • | • | • | • | • | • | • | 292 |
| Brake light switch – check † | | • | • | • | • | • | • | • | • | 26 |
| Steering play – check † | | • | • | • | • | • | • | • | • | 26 |
| Steering stem bearing – lubricate | 2 years | | | | | • | | | | 150 |
| Front fork oil – change | | | | • | | • | | • | | 152 |
| Front fork oil seal – clean | | | • | • | • | • | • | • | • | 151 |
| Tire wear – check † | | | • | • | • | • | • | • | • | 297 |
| Wheel bearing – lubricate | 2 years | | | | | • | | | | 297 |
| Speedometer gear – lubricate | 2 years | | | | | • | | | | 297 |
| Spoke tightness and rim runout – check † | | • | • | • | • | • | • | • | • | 297 |
| Swing arm pivot – lubricate | | | | • | | • | | • | | 297 |
| Battery electrolyte level – check † | month | • | • | • | • | • | • | • | • | 156 |
| General lubrication – perform | | | • | • | • | • | • | • | • | 292 |
| Nut, bolt, and fastener tightness—check † | | • | | • | | • | | • | | 294 |

* For higher odometer readings, repeat at the frequency interval established here.

† Replace, add, adjust or torque if necessary.

Specifications

SPECIFICATIONS

The specifications for the 1982 KZ305-B1 are shown on p. 285.

PERIODIC MAINTENANCE CHART

The Periodic Maintenance Chart for the 1982 KZ305-B1 is shown on p. 291.

Adjustment

The adjustment procedures for the following eleven items are the same as those for the 1981 KZ305-A1. Refer to the supplement for the 1981 KZ305-A1.

- IGNITION TIMING (See p. 245)
- CAMSHAFT CHAIN (See p. 245)
- THROTTLE CABLE (See p. 245)
- REAR SHOCK ABSORBER (See p. 245)
- LUBRICATION (See p. 245)
- SPARK PLUGS (See p. 245)
- CARBURETORS (See p. 245)
- FUEL SYSTEM (See p. 245)
- BRAKES (See p. 245)
- WHEEL BALANCE (See p. 245)
- HEADLIGHT (See p. 246)

CLUTCH

The adjustment procedures for the 1982 KZ305-B1 are the same as those for the 1982 Z250-A4. Refer to p. 270.

DRIVE BELT

At all times the tension of the belt should be maintained within usable range in order to run safely and prolong the life of the belt. A belt that has been mal-adjusted will result in shorter belt life. A belt that has been too loosely may slip over the pulley teeth. If the belt teeth slip over the pulley teeth, adjust the tension immediately.

Drive Belt Tension:

The adjustment of the belt can be obtained through the use of either of the following two procedures depending on whether or not tension gauge 57001-1155 is available. To obtain more reliable result, the adjustment should be performed by use of the tension gauge.

NOTE: 1. Belt tension must be check when the engine is cold (room or atmospheric temperature) and the belt is dry condition.

2. Belt tension also should be checked at first 800 km ride after belt replacement.

Tension Inspection without tension gauge

- Set the motorcycle up on its center stand.
- Visually inspect the belt for damage.
- ★If it is damaged, replace it with a new one.
- Apply 44N (4.5 kg) of force on the belt midway between the pulleys and measure the deflection.

Drive Belt Tension Inspection

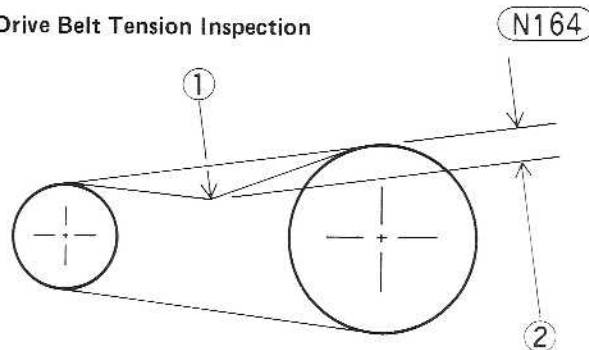

1. 44N (4.5 kg) of force
2. Deflection

Table N50 Drive Belt Tension (without tension gauge)

Usable Range: 7.5 – 16.5 mm

★If the deflection is out of the usable range, adjust it.

Tension Inspection with tension gauge

- Set the motorcycle up on its center stand.
- Visually inspect the belt for damage.
- ★If it is damaged, replace it with a new one.
- Position the tension gauge between the tension gauge positioning bracket on the swing arm and the upper run of the drive belt. Place the plate of the tension gauge on the top of the belt teeth, and the projection of the lower stop of the tension gauge into the hole of the tension gauge positioning bracket.

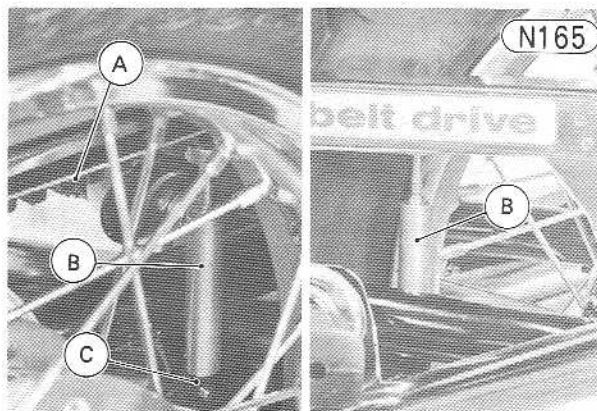

A. Drive Belt
B. Tension Gauge

C. Positioning Bracket

Construction of Tension Gauge

N166

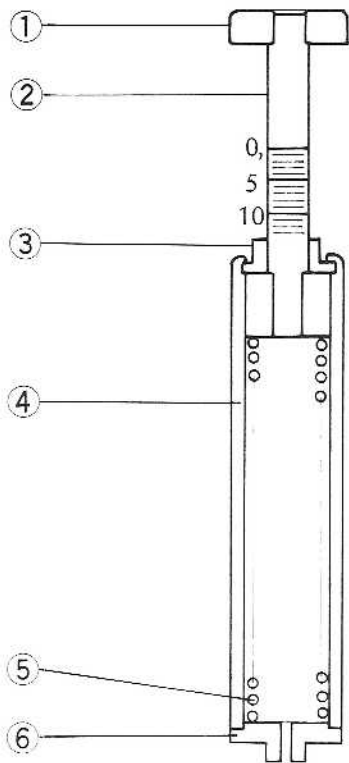

- 1. Plate
- 2. Rod
- 3. Upper Stop
- 4. Body
- 5. Spring
- 6. Lower Stop

•Check the tension at several positions by rotating the rear wheel. Adjustment is acceptable when the top of the upper stop is within usable range on the rod.

Table 51 Drive Belt Tension (with tension gauge)

Usable Range: 3 – 8 mm

★If the tension is out of the usable range, adjust it.

Tension Adjustment

•Loosen the rear torque link nut.

CAUTION If you don't loosen the torque link nut, it may lead to the brake parts damage when the adjusters are set.

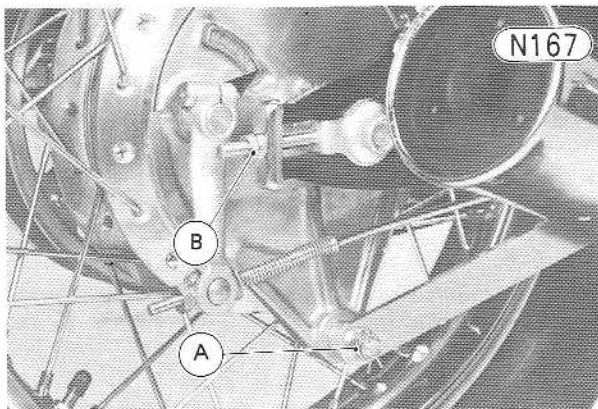

A. Torque Link Nut B. Belt Adjuster Locknut

- Loosen the left and right belt adjuster locknuts.
- Remove the cotter pin, and loosen the axle nut.
- When the belt is too tight, back out both the belt adjusting nuts evenly, and kick the wheel forward until the belt is too loose.
- Turn in both the belt adjusting nuts evenly until the drive belt has the correct tension. To keep the belt and wheel aligned, the notch on the left belt adjuster should align with the same swing arm mark that the right belt adjuster notch aligns with.

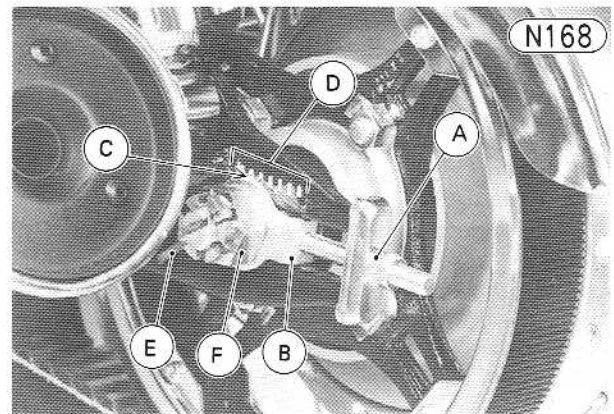

A. Adjusting Nut B. Belt Adjuster C. Notch D. Swing Arm Marks E. Axle Nut Cotter Pin F. Axle Nut

- NOTE:**
1. Wheel alignment can also be checked using the straightedge or string method.
 2. When the belt is replaced, adjust the tension to the upper limit.

WARNING Misalignment of the wheel will result in abnormal wear, and may result in an unsafe riding condition.

- Tighten both belt adjuster locknuts, and make sure the axle stays aligned.
 - Center the brake panel assembly in the brake drum. This is done by tightening the axle nut lightly, spinning the wheel, and depress the brake pedal forcefully. The partially tightened axle nut allows the brake panel assembly to center itself within the brake drum.
- NOTE:** This procedure can prevent a soft, or "spongy feeling" brake.
- Tighten the axle nut to the specified torque.

Table 52 Tightening Torque

Axle Nut: 88 N-m (9.0 kg-m, 65 ft-lb)
Torque Link Nut: 29 N-m (3.0 kg-m, 22 ft-lb)

- Check the tension again, and readjust if necessary.
- Insert a new cotter pin through the axle nut and axle, and spread its ends.
- Tighten the rear torque link nut to the specified torque.

WARNING If the axle and torque link nuts are not securely tightened, an unsafe riding condition may result.

- Check the rear brake play.

Drive Belt Wear:

Wear Inspection

- Visually inspect the belt for wear.
- ★ If the nylon fabric facing of any portion is worn off, and the polyurethane compound is exposed, replace the drive belt immediately with a new one. Whenever the belt is replaced, inspect the engine and rear pulleys, and replace them if necessary.

Drive Belt Construction

N169

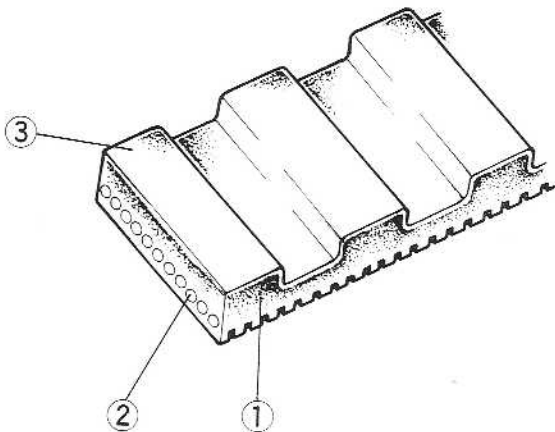

1. Polyurethane Compound (Black)
2. Kevlar Tensile Cord (Yellow)
3. Nylon Fabric Facing (White)

WARNING 1. A belt worn past the nylon fabric facing must be replaced. Such a worn belt may cause a serious accident.

2. The drive system is designed for use with the standard belt. For maximum strength and safety, the standard belt must be used for replacement.

Table N53 Standard Belt

| Make | Size |
|-------|---------------------------------------|
| Gates | 14 mm Pitch x 35 mm Width x 121 Teeth |

Disassembly

TORQUE AND LOCKING AGENT

Refer to p. 246, noting the following.

1. Cross tighten the clutch spring bolts evenly to 8.8 N-m (0.9 kg-m, 78 in-lb) of torque.
2. Tighten the engine pulley nut to 69 N-m (7.0 kg-m, 51 ft-lb) of torque.
3. Tighten the rear pulley nut to 29 N-m (3.0 kg-m, 22 ft-lb) of torque.

CURBURETORS

The procedures for the 1982 KZ305-B1 are the same as those for the 1981 KZ305-A1. Refer to p. 246.

The procedures for the following three items are the same as those for the 1981 Z250-A3. Refer to the supplement for the 1981 Z250-A3.

- CAMSHAFT CHAIN TENSIONER (See p. 223)
- PISTON, PISTON RINGS (See p. 224)
- TRANSMISSION (See p. 225)

CYLINDER HEAD COVER, ROCKER ARM

The procedures for the 1982 KZ305-B1 are the same as those for the 1980 Z250-A2. Refer to p. 184.

The procedures for the following two items are the same as those for the 1981 KZ305-A1. Refer to the supplement for the 1981 KZ305-A1.

- FRONT WHEEL (See p. 247)
- FRONT BRAKE (See p. 250)

The procedures for the following two items are the same as those for the 1980 Z250-B1. Refer to the supplement for the 1980 Z250-B1.

- RIM (See p. 205)
- SPOKES (See p. 206)

ENGINE PULLEY COVER

Remove and install the engine pulley cover referring to "ENGINE SPROCKET COVER" in the supplement for the 1982 Z250-A4. Refer to p. 272.

The procedures for the following three items are the same as those for the 1982 Z250-A4. Refer to the supplement for the 1982 Z250-A4.

- CLUTCH RELEASE (See p. 272)
- RIGHT ENGINE COVER (See p. 274)
- CLUTCH (See p. 274)

ENGINE PULLEY

Removal:

- Remove the engine pulley cover (p. 294)
- Loosen the rear torque link nut.

CAUTION If you don't loosen the torque link nut, it may lead to the brake parts damage when the adjusters are set.

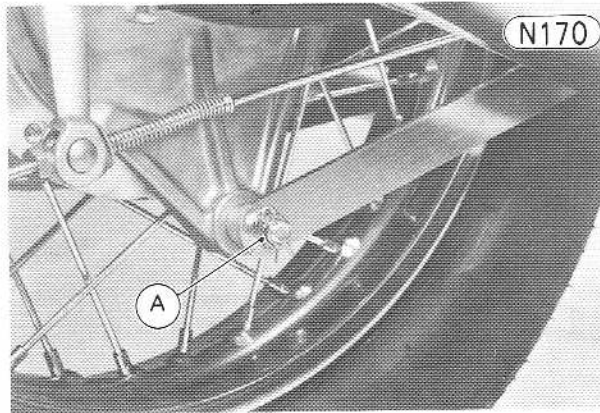

A. Torque Link Nut

- Loosen the left and right belt adjuster locknuts.
- Remove the cotter pin, and loosen the axle nut.
- Back out both the belt adjusting nuts evenly, and kick the wheel forward so that the belt is too loose.

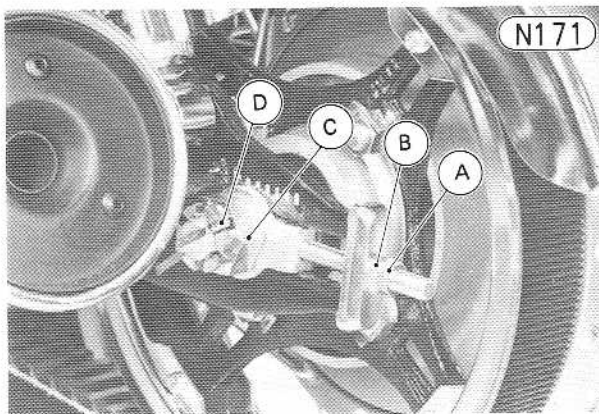

A. Belt Adjuster Locknut
B. Belt Adjusting Nut
C. Axle Nut
D. Axle Nut Cotter Pin

- Straighten the sides of the splined washer that is bent over the sides of the engine pulley nut.
- Holding the engine pulley steady using the holder (special tool), and remove the nut, splined washer, and engine pulley with the drive belt.

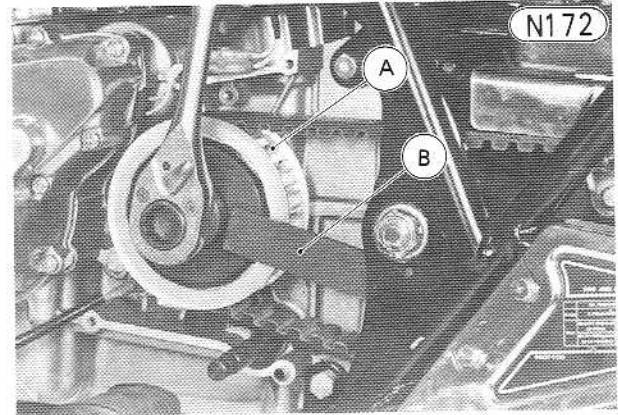

A. Engine Pulley
B. Holder (57001-1037)

- Free the engine pulley from the drive belt.

Installation:

- Fit the belt on the engine pulley.
- Mount the engine pulley, and install the splined washer on the output shaft fitting their splines.
- Install the engine pulley nut, and then tighten the nut to 69 N-m (7.0 kg-m, 51 ft-lb) of torque while using the holder to hold the pulley steady.
- Bend the sides of the splined washer over the sides of the nut.
- Install the engine pulley cover.
- Adjust the drive belt tension using the tension gauge (p.293).

EXTERNAL SHIFT MECHANISM

Refer to p. 65, noting the following.

1. The drive belt guard inside the engine pulley cover is not installed on this motorcycle.

DRIVE BELT

Removal:

- Set the motorcycle up on its center stand.
 - Remove the belt guard.
 - Loosen the nut at the rear end of the torque link.
- CAUTION** If you don't loosen the torque link nut, it may lead to the brake parts damage when the adjusters are set.
- Remove the axle nut cotter pin and axle nut.
 - Loosen the left and right belt adjuster locknuts.

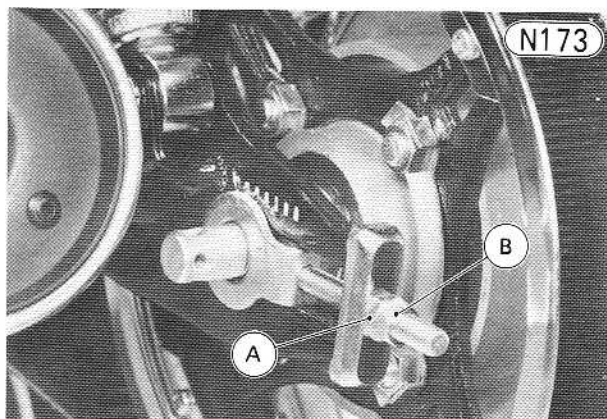

A. Adjusting Nut

B. Locknut

- Back out both the belt adjusting nuts fully, and push fully the wheel forward for easier belt removal.
- Remove the rear wheel (p. 296).
- Mark the direction of belt rotation on the belt with chalk so that the belt can be reinstalled in the same direction to ensure longer belt life.
- Remove the engine pulley cover (p. 294).
- Remove the engine pulley (P. 295).
- Remove the swing arm.
- Free the belt from the motorcycle.

Installation Notes:

1. Be sure that the belt is installed in the same direction as before removal. When installing a new belt, the red paint mark on the side of the belt should face inwards of the motorcycle.

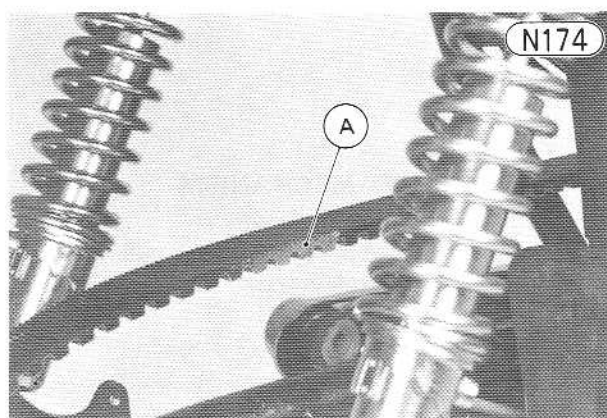

A. Red Paint Mark

2. Tighten the engine pulley nut to 69 N-m (7.0 kg-m, 51 ft-lb) of torque.
3. Bend the sides of the splined washer over the sides of the engine pulley nut.
4. Check that the engine pulley cover knock pins (2) are in place.
5. Lubricate the swing arm pivot (p. 232).
6. Apply grease to the cap inner surfaces and install the cap on each side of the swing arm pivot.

7. Tighten the pivot shaft nut to 78 N-m (8.0 kg-m, 58 ft-lb) of torque.
8. Apply a little grease to inside surface of the hole in the coupling where the rear hub fits.
9. Check to see that the wheel coupling, coupling collar, coupling sleeve, rubber damper, and brake panel are in place.
10. Adjust the drive belt tension using the tension gauge (p. 293).
11. Adjust the rear brake (p. 193).

REAR WHEEL, BRAKE

Refer to p.p. 202 – 205, noting the following.

Removal:

- Raise the rear wheel off the ground.
- Remove the mufflers (p. 44).
- Remove the belt guard.
- Take out the cotter pin, and remove the axle nut.
- Remove the clip, nut, lockwasher, and bolt at the rear end of the torque link.

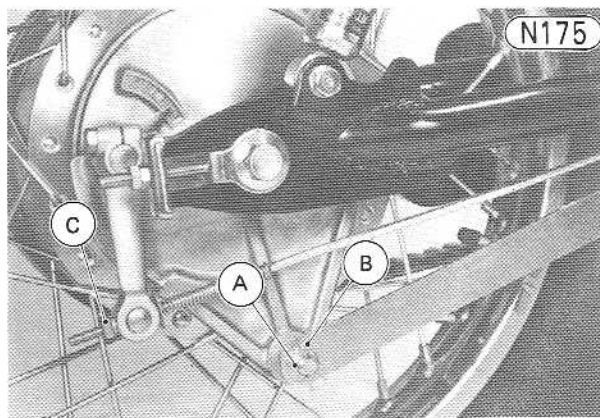

A. Torque Link Nut

B. Clip

C. Adjusting Nut

- Remove the adjusting nut from the end of the brake rod, and free the rod from the cam lever.
- Remove the spring seat and spring from the brake rod, and remove the brake rod joint from the brake cam lever.
- Loosen the left and right belt adjuster locknuts.
- Back out both the belt adjusting nuts evenly, and push fully the wheel forward for easier wheel removal.

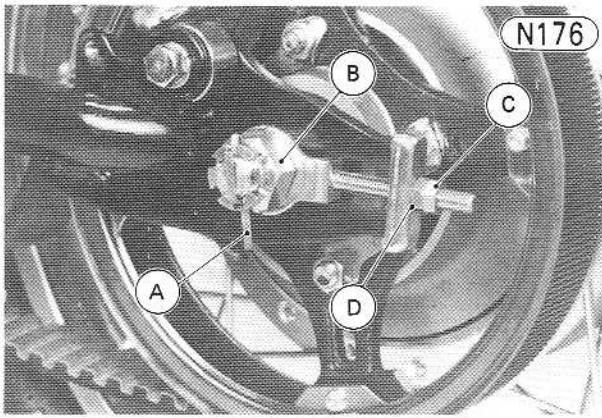

A. Cotter Pin, B. Axle Nut C. Belt Adjuster Locknut D. Belt Adjusting Nut

- Raise the rear wheel enough to pull out the axle, and remove the axle. The spacer will drop out.

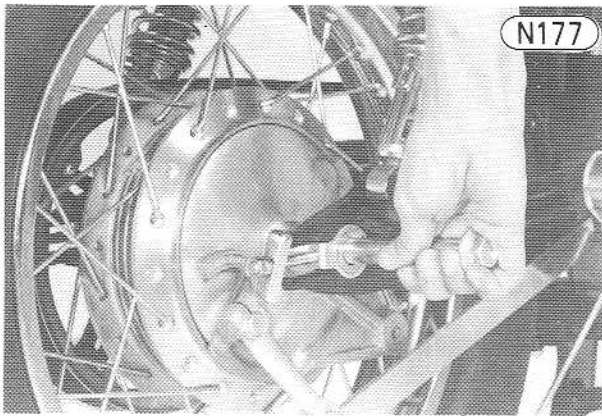

- Slip the drive belt off the rear pulley, and free the rear wheel from the motorcycle.

Installation:

- Apply a little grease to the inside surface of the hole in the coupling where the rear hub fits.
- Check to see that the wheel coupling, coupling collar, coupling sleeve, rubber damper, and brake panel are in place.
- Slip the rear wheel into the end of the swing arm.
- Fit the belt onto the rear pulley.
- Slide the axle through from right to left. Do not forget to put the spacer in place between the brake panel and the right chain adjuster.
- Attach the rear axle nut loosely.
- Fit the brake rod joint to the cam lever.
- Install the spring and spring seat on the end of the brake rod, fit the rod through the joint, and screw on the adjusting nut.
- Insert the torque link bolt into the brake panel, and install the torque link, lockwasher, and nut finger tight.

- Install the mufflers (p. 44).
- Adjust the drive belt using the tension gauge (p. 293).
- Adjust the rear brake (p. 193).
- Check the rear brake light switch and adjust if necessary (p. 26).

Maintenance

The following eleven items are the same as those for the 1981 KZ305-A1. Refer to the supplement for the 1981 KZ305-A1.

- ROCKER ARMS, SHAFTS (See p. 250)
- CAMSHAFT (See p. 250)
- CAMSHAFT CHAIN, GUIDES, TENSIONER (See p. 250)
- CYLINDER HEAD, VALVES (See p. 250)
- SWING ARM (See p. 250)
- IGNITION SYSTEM (See p. 250)
- CYLINDER BLOCK, PISTONS (See p. 251)
- TRANSMISSION (See p. 251)
- WHEELS (See p. 251)
- BRAKES (See p. 254)
- SPARK PLUGS (See p. 254)

CARBURETORS

The maintenance procedures are the same as those for the 1982 KZ305-A2. Refer to p. 288.

PULLEYS

The pulleys have a special tooth profile to transmit the engine power with high efficiency. A worn-out pulley may allow the belt teeth to slip.

- Measure the diameter of the engine and rear pulleys at the toe of the teeth.
- ★ If the pulleys are worn down to less than the service limit, replace them.

Table N54 Pulley Diameter

| | Engine (23 Teeth) | Rear (50 Teeth) |
|---------------|-------------------|-----------------|
| Service Limit | 99.4 mm | 219.4 mm |

Pulley Diameter Measurement

N178

(A) Engine Pulley

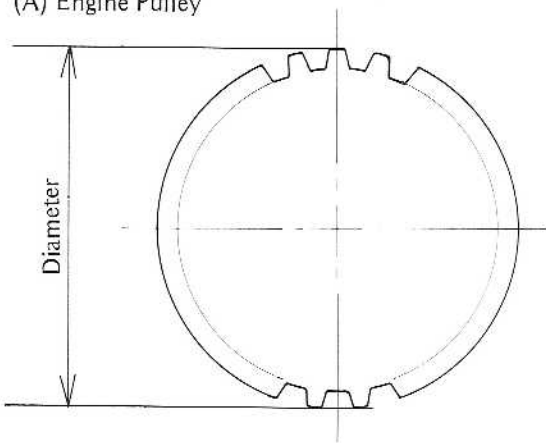

(B) Rear Pulley

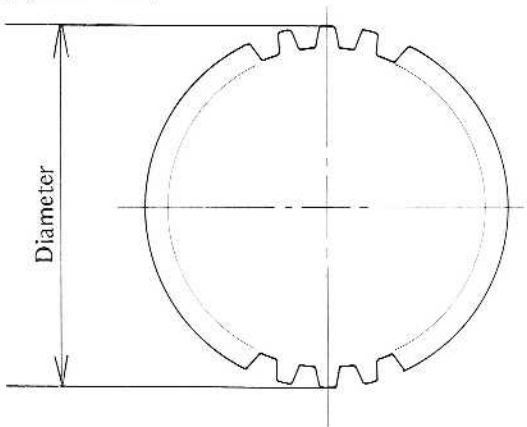

- Visually inspect the pulleys for wear.
- ★Replace them if they are worn as illustrated.

Pulley Teeth

N179

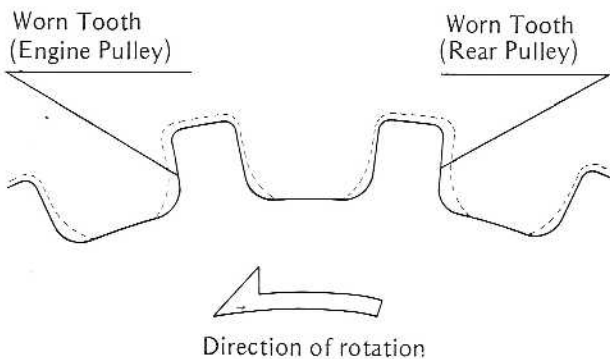

NOTE: If the pulley requires replacement, the belt is probably worn. Whenever replacing the pulley, inspect the belt.

Appendix

SPECIAL TOOLS

The special tools for the 1982 KZ305-B1 are the same as those for the 1981 KZ305-A1 with the following exceptions. Refer to p.254.

1. Use the new vacuum gauge (P/N: 57001-1152) to synchronize the carburetors. (See Fig. N162 on p. 276.)
2. Use the holder (P/N: 57001-1037) to hold the engine pulley steady.

N180

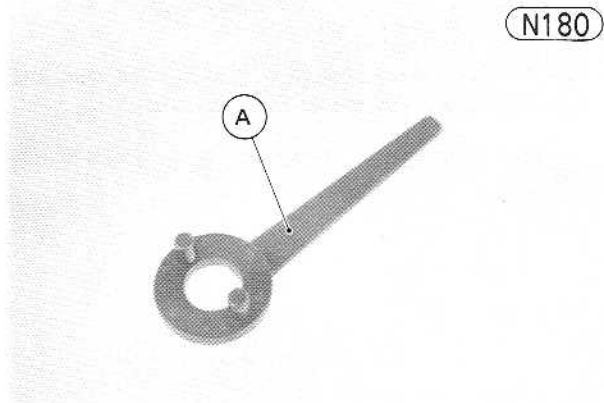

A. Holder: 57001-1037

3. Use the tension gauge (P/N: 57001-1155) to check the belt tension.

N181

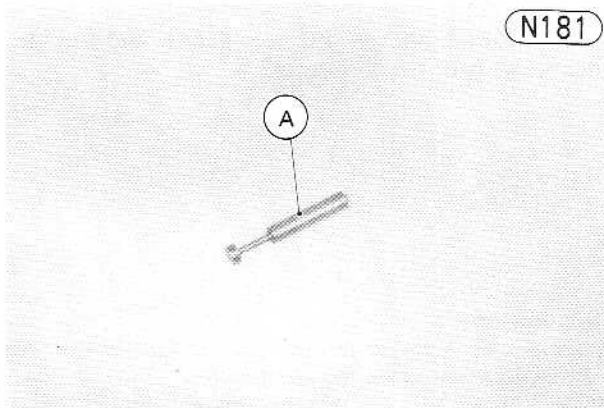

A. Tension Gauge: 57001-1155

WIRING DIAGRAM

The wiring diagram for the KZ305B is shown on p. 255.

Supplement for 1982 KZ305-D1

NOTE: The maintenance and repair procedures for the KZ305D are newly included in this section. Unless otherwise noted, procedures for the 1982 KZ305-D1 are the same as those for their standard model 1979 Z250-A1.

Table of Contents

| | |
|---|-----|
| MODEL IDENTIFICATION | 300 |
| SPECIFICATION | |
| SPECIFICATIONS | 302 |
| PERIODIC MAINTENANCE CHART | 302 |
| ADJUSTMENT | |
| IGNITION TIMING | 302 |
| CAMSHAFT CHAIN | 302 |
| THROTTLE CABLE | 302 |
| REAR SHOCK ABSORBER | 302 |
| LUBRICATION | 302 |
| FUEL SYSTEM | 302 |
| HEADLIGHT | 302 |
| BRAKES | 302 |
| CLUTCH | 302 |
| DRIVE BELT | 302 |
| DISASSEMBLY | |
| TORQUE AND LOCKING AGENT | 302 |
| CARBURETORS | 302 |
| CAMSHAFT CHAIN TENSIONER | 302 |
| PISTON, PISTON RINGS | 302 |
| TRANSMISSION | 302 |
| FRONT WHEEL | 302 |
| FRONT BRAKE | 302 |
| CYLINDER HEAD COVER, ROCKER ARM | 302 |
| CLUTCH RELEASE | 302 |
| RIGHT ENGINE COVER | 302 |
| CLUTCH | 302 |
| ENGINE PULLEY COVER | 302 |
| ENGINE PULLEY | 302 |
| EXTERNAL SHIFT MECHANISM | 302 |
| DRIVE BELT | 302 |
| REAR WHEEL, BRAKE | 302 |
| MAINTENANCE | |
| ROCKER ARMS, SHAFTS | 303 |
| CAMSHAFT | 303 |
| CAMSHAFT CHAIN, GUIDES, TENSIONER | 303 |
| CYLINDER HEAD, VALVES | 303 |
| SWING ARM | 303 |
| IGNITION SYSTEM | 303 |
| CYLINDER BLOCK, PISTONS | 303 |
| TRANSMISSION | 303 |
| CARBURETORS | 303 |
| WHEELS | 303 |
| BRAKES | 303 |
| PULLEYS | 303 |
| APPENDIX | |
| SPECIAL TOOLS | 303 |
| WIRING DIAGRAM | 303 |

Model Identification

KZ 305-D1 Left Side View



KZ 305-D1 Right Side View



PERIODIC MAINTENANCE CHART (KZ305-D1)

The maintenance and adjustments must be done in accordance with this chart to keep the motorcycle in good running condition. The initial maintenance is vitally important and must not be neglected.

| OPERATION | FREQUENCY | ODOMETER READING* | | | | | | | See Page |
|---|-------------|-------------------------------------|--------|----------|-----------|-----------|-----------|-----------|----------|
| | | Whichever comes first ↓ Every | 800 km | 5,000 km | 10,000 km | 15,000 km | 20,000 km | 25,000 km | |
| Engine oil – change | year | • | • | • | • | • | • | • | 22 |
| Oil filter – replace | | • | | • | | • | | • | 22 |
| Fuel system – clean | | | | • | | • | | • | 302 |
| Fuel hose – replace | 4 years | | | | | | | | – |
| Spark plug – clean and gap † | | • | • | • | • | • | • | • | 12 |
| Ignition timing – check † | | • | • | • | • | • | • | • | 302 |
| Timing advancer – lubricate | | | | • | | • | | • | 303 |
| Valve clearance – check † | | • | • | • | • | • | • | • | 16 |
| Air cleaner element – clean | | | • | | • | | • | | 115 |
| Air cleaner element – replace | 5 cleanings | | | • | | • | | • | 115 |
| Throttle grip play – check † | | • | • | • | • | • | • | • | 302 |
| Idle speed-check † | | • | • | • | • | • | • | • | 18 |
| Carburetor synchronization – check † | | • | • | • | • | • | • | • | 18 |
| Clutch – adjust | | • | • | • | • | • | • | • | 302 |
| Drive belt tension – check † | | • | • | • | • | • | • | • | 302 |
| Drive belt wear – check † | | • | • | • | • | • | • | • | 302 |
| Brake lining wear – check † | | | • | • | • | • | • | • | 303 |
| Brake fluid level – Check † | month | • | • | • | • | • | • | • | 303 |
| Brake fluid – change | | | | • | | • | | • | 303 |
| Brake hose – replace | 4 years | | | | | | | | 303 |
| Master cylinder cup and dust seal – replace | 2 years | | | | | | | | 303 |
| Caliper piston seal and dust seal – replace | 2 years | | | | | | | | 303 |
| Brake camshaft – lubricate | 2 years | | | | | • | | | 303 |
| Brake play – check † | | • | • | • | • | • | • | • | 302 |
| Brake light switch – check † | | • | • | • | • | • | • | • | 26 |
| Steering play – check † | | • | • | • | • | • | • | • | 26 |
| Steering stem bearing – lubricate | 2 years | | | | | • | | | 150 |
| Front fork oil – change | | | | • | | • | | • | 152 |
| Front fork oil seal – clean | | | • | • | • | • | • | • | 151 |
| Tire wear – check † | | | • | • | • | • | • | • | 303 |
| Wheel bearing – lubricate | 2 years | | | | | • | | | 303 |
| Speedometer gear – lubricate | 2 years | | | | | • | | | 303 |
| Swing arm pivot – lubricate | | | | • | | • | | • | 303 |
| Battery electrolyte level – check † | month | • | • | • | • | • | • | • | 156 |
| General lubrication – perform | | | • | • | • | • | • | • | 302 |
| Nut, Bolt, and fastener tightness – Check † | | • | | • | | • | | • | 302 |

* For higher odometer readings, repeat at the frequency interval established here.

† Replace, add, adjust or torque if necessary.

Specifications

SPECIFICATIONS

The specifications for the 1982 KZ305-D1 are shown on p. 285.

PERIODIC MAINTENANCE CHART

The Periodic Maintenance Chart for the 1982 KZ305-D1 is shown on p. 301.

Adjustment

The adjustment procedures for the following five items are the same as those for the 1981 Z250-A3. Refer to the supplement for the 1981 Z250-A3.

- IGNITION TIMING (See p. 217)
- CAMSHAFT CHAIN (See p. 217)
- THROTTLE CABLE (See p. 217)
- REAR SHOCK ABSORBER (See p. 217)
- LUBRICATION (See p. 218)

The adjustment procedures for the following two items are the same as those for the 1981 KZ305-A1. Refer to the supplement for the KZ305-A1.

- FUEL SYSTEM (See p. 245)
- HEADLIGHT (See p. 246)

BRAKES

This motorcycle has the front disc and rear drum brake system. Adjust the front and rear brakes referring to p.25 (front brake) and p.193 (rear brake).

CLUTCH

The adjustment procedures for the 1982 KZ305-D1 are the same as for the 1982 Z250-A4. Refer to p.270.

DRIVE BELT

The adjustment procedures for the 1982 KZ305-D1 are the same as those for the 1982 KZ305-B1. Refer to p. 292.

Disassembly

TORQUE AND LOCKING AGENT

This is the same as those for the 1982 KZ305-B1. Refer to P. 294.

The procedures for the following six items are the same as those for the 1981 Z250-A3. Refer to the supplement for the 1981 Z250-A3.

- CARBURETORS (See p. 218)
- CAMSHAFT CHAIN TENSIONER (See p. 223)
- PISTON, PISTON RINGS (See p. 224)
- TRANSMISSION (See p. 225)
- FRONT WHEEL (See p. 225)
- FRONT BRAKE (See p. 227)

CYLINDER HEAD COVER, ROCKER ARM

The disassembly and assembly procedures are the same as those for the 1980 Z250-A2. Refer to p.184.

The procedures for the following three items the same as those for the 1982 Z250-A4. Refer to the supplement for the 1982 Z250-A4.

- CLUTCH RELEASE (See p. 272)
- RIGHT ENGINE COVER (See p. 274)
- CLUTCH (See p. 274)

ENGINE PULLEY COVER

Remove and install the engine pulley cover referring to "ENGINE SPROCKET COVER" in the supplement for the 1982 Z250-A4. Refer to p. 272.

The procedures for the following three items are the same as those for the 1982 KZ305-B1. Refer to the supplement for the 1982 KZ305-B1.

- ENGINE PULLEY (See p. 294)
- EXTERNAL SHIFT MECHANISM (See p. 295)
- DRIVE BELT (See p. 295)

REAR WHEEL, BRAKE

Removal and Installation:

The procedures are the same as those for the 1982 KZ305-B1. Refer to p. 296.

Rear Brake Disassembly and Assembly, Wheel Coupling Disassembly and Assembly, and Rear Hub Disassembly and Assembly:

The procedures are the same as those for the 1981 KZ305-C1. Refer to p.p.260—263.

Maintenance

WIRING DIAGRAM

The wiring diagram for the KZ305D is shown on p. 255.

The following two items are the same as those for the 1980 Z250-A2. Refer to the supplement for the 1980 Z250-A2.

- ROCKER ARMS, SHAFTS (See p.185)
- CAMSHAFT (See p.185)

The following four items are the same as those for the 1981 Z250-A3. Refer to the supplement for the 1981 Z250-A3.

- CAMSHAFT CHAIN, GUIDES, TENSIONER (See p.230)
- CYLINDER HEAD, VALVES (See p.230)
- SWING ARM (See p.232)
- IGNITION SYSTEM (See p.232)

The following two items are the same as those for the 1981 KZ305-A1. Refer to the supplement for the KZ305-A1.

- CYLINDER BLOCK, PISTONS (See p.251)
- TRANSMISSION (See p.251)

The following two items are the same as those for the 1981 KZ305-C1. Refer to the supplement for the KZ305-C1.

- CARBURETORS (See p.264)
- WHEELS (See p.264)

BRAKES

This motorcycle has the front disc and rear brake system, and maintenance procedures are the same as those for the 1979 Z250-A1 (front brake) and 1980 Z250-B1 (rear brake). Refer to p.p. 145 ~ 150 (front brake) and 209 ~ 211 (rear brake).

PULLEYS

The maintenance procedures are the same as those for the 1982 KZ305-B1. Refer to p. 297.

Appendix

SPECIAL TOOLS

The special tools for the 1982 KZ305-D1 are the same as those for the 1982 KZ305-B1. Refer to p. 298.

Index

- Air Cleaner 115
- Ball Bearings 138
- Battery 156
- Brake Light Switch 26

- Camshaft 47,119,185,207,250,263,297,303
- Camshaft Chain 16,120,217,230,238,245,250,259
263,292,297,302,303
- Camshaft Chain Guide..... 120,230,238,250,263,297,303
- Camshaft Chain Tensioner 120,223,230,238,297
246,250,259,263,294,302,303
- Carburetors 18,39,115,184,197,218,230
238,245,246,250,259,264,288,292,294,297,302,303
- Charging System 158
- Clutch 20,62,131,184,197,246,259,270,274
282,288,292,294,302
- Clutch Release 55,272,282,288,294,302
- Connecting Rods 130
- Contact Breaker 60
- Crankcase Split 72
- Crankshaft 130
- Cylinder Block 52,127,185,207,224,238,251
263,297,303
- Cylinder Head 48,121,230,238,250,263,297,303
- Cylinder Head Cover 44,184,197,246,259,294,302

- Drive Belt 292,295,302
- Drive Chain 24,97,144

- Electric Starter System 164
- Engine Lubrication 135
- Engine Oil 21
- Engine Performance Curves
Z250A 8
Z250B 190
- Engine Pulley 295,297,302,303
- Engine Pulley Cover 294,302
- Engine Removal 70
- Engine Sprocket 55,145,225,238,246,253,259,263
- Engine Sprocket Cover 54,272,282,288
- External Shift Mechanism 65,232,295,302

- Flow Charts
Disassembly—Chassis 88
Disassembly—Engine Installed 38
Disassembly—Engine Removed 69
Engine Removal 68
- Front Brake
Disc 25,92,145,227,245,250,254,259,264
292,294,297,302,303
Drum 192,198,209
- Front Fork 110,151,271,276
- Front Wheel 89,198,207,225,247,251,259,264
294,297,302,303
- Fuel System 22,245,259,270,282,292,302
- Fuel Tank 39

- General Lubrication 29,195,218,245,259
- Handlebar 104
- Headlight 28,246,259,271,292,302
- Horn 28,170

- Ignition Switch 166
- Ignition System 160,232,238,250,263,297,303
- Ignition Timing 12,217,238,245,259,292,302
- Introduction to Disassembly 32

- Lighting System 167
- Lubrication
Engine 135
General 29,195,218,245,259,292,302

- Model Identification
Z250A 4,183,213,266
Z250B 187,237,280
KZ305A 241,284
KZ305B 290
KZ305C 257
KZ305D 300
- Mufflers 44,197

- Needle Bearings 138
- Neutral Indicator Switch 166

- Oil Pump 64
- Oil Seals 138

- Periodic Maintenance Chart
Z250A 10,216,269
Z250B 191,238,282
KZ305A 244,287
KZ305B 292
KZ305C 259
KZ305D 302
- Pistons 53,127,185,207,224,238,246,251
259,263,294,297,302,303
- Piston Rings 53,224,238,246,259,294,302

- Rear Brake
Disc 25,100,145
Drum 193,202,209,245,250,254,259,264
292,295,297,302,303
- Rear Brake Light Switch 26
- Rear Pulley 297,303
- Rear Shock Absorbers 24,217,238,245,259,292,302
- Rear Sprocket 145,253,263
- Rear Wheel 97,202,207,250,251,259,264,295
297,302,303

- Right Engine Cover 62,274,282,288,294,302
- Rim 205,250,264,294
- Rocker Arm 44,119,184,185,197
207,246,250,259,263,294,297,302,303
- Rocker Shaft 119,185,207,250,263,297,303
- Running Performance Curves
Z250A 9
Z250B 9
- Spark Plugs 12,245,254,292,297

306 INDEX

| | |
|------------------------------|---|
| Special Tools | |
| Z250A | 175,233,276 |
| Z250B | 211,238,282 |
| KZ305A | 254,288 |
| KZ305B | 298 |
| KZ305C | 264 |
| KZ305D | 303 |
| Specifications | |
| Z250A | 6,214,267 |
| Z250B | 188,238,282 |
| KZ305A | 242,285 |
| KZ305B | 292 |
| KZ305C | 259 |
| KZ305D | 302 |
| Spoke | 206,250,294 |
| Sprocket | |
| Engine | 55,145,225,238,246,253,259,263 |
| Rear | 145,253,263 |
| Starter Motor | 58 |
| Stator (Alternator) | 56 |
| Steering | 26 |
| Steering Stem | 106,150 |
| Steering Stem Bearings | 109 |
| Supplement for | |
| Z250A | 182,212,265 |
| Z250B | 186,236 |
| KZ305A | 240,283 |
| KZ305B | 289 |
| KZ305C | 256 |
| KZ305D | 299 |
| Swing Arm | 152,232,238,250,263,297,303 |
| Switch | |
| Brake Light | 26 |
| Ignition | 166 |
| Neutral Indicator | 166 |
| Throttle Cable | 17,217,238,245,259,292,302 |
| Timing Advancer | 61 |
| Torque and Locking Agent | |
| Z250A | 33,184,218,272 |
| Z250B | 195,238,282 |
| KZ305A | 246,288 |
| KZ305B | 294 |
| KZ305C | 259 |
| KZ305D | 302 |
| Transmission | 83,133,225,232,238 246,251,259,263,294,297,302,303 |
| Troubleshooting Guide | 171 |
| Valves | 50,121,230,238,250,263,297,303 |
| Valve Clearance | 16 |
| Valve Guides | 50 |
| Wheel Balance | 27,194,245,292 |
| Wiring Diagram for | |
| Z250A | 179,276 |
| Z250B | 211,282 |
| KZ305A | 254 |
| KZ305B | 298 |
| KZ305C | 264 |
| KZ305D | 303 |

MODEL APPLICATION

| Year | Model | Beginning Frame No. |
|------|----------|---------------------|
| 1979 | Z250-A1 | KZ250A-000001 |
| 1980 | Z250-A2 | KZ250A-012001 |
| | Z250-B1 | KZ250B-000001 |
| 1981 | Z250-A3 | KZ250A-029301 |
| | Z250-B2 | KZ250B-001301 |
| | KZ305-A1 | JKAKZLA1(2)BA000001 |
| | KZ305-C1 | JKAKZLC1(6)BA000001 |
| 1982 | Z250-A4 | KZ250A-038801 |
| | Z250-B3 | KZ250B-002201 |
| | KZ305-A2 | JKAKZLA1(3)CA009601 |
| | KZ305-B1 | JKAKZLB1(2)CA000001 |
| | KZ305-D1 | JKAKZLD1(6)CA000001 |

() : This marked digit in the frame number changes from one machine to another.

| | | | |
|---------------|-----------|-------------|--|
| LOCATION | | E 84 | |
| B07A2 | | | |
| PART NO. | | QTY. | |
| 99924-1019-04 | | 1 | |
| S/M KZ305A | | | |
| 0024-40-95 | | | |
| MEMO: 64132 | | | |
| DEALER NO. | ORDER NO. | INVOICE NO. | |
| 1966 | TN2284 | 0034160 | |

KAWASAKI
HEAVY INDUSTRIES, LTD.
MOTORCYCLE DIVISION

Part No. 99924-1019-04

Printed in Japan